



Lexmark™

MX610, MX611, MX617de, and XM3150 MFPs

7016-630, -67x

Service Manual

- [Start diagnostics](#)
- [Maintenance](#)
- [Safety and notices](#)
- [Trademarks](#)
- [Index](#)

January 05, 2023

www.lexmark.com

Product information

Product name:

Lexmark MX610, MX611, MX617de, and XM3150

Machine type:

7016

Model(s):

630, 670, 675

Edition notice

January 05, 2023

The following paragraph does not apply to any country where such provisions are inconsistent with local law: LEXMARK INTERNATIONAL, INC., PROVIDES THIS PUBLICATION “AS IS” WITHOUT WARRANTY OF ANY KIND, EITHER EXPRESS OR IMPLIED, INCLUDING, BUT NOT LIMITED TO, THE IMPLIED WARRANTIES OF MERCHANTABILITY OR FITNESS FOR A PARTICULAR PURPOSE. Some states do not allow disclaimer of express or implied warranties in certain transactions; therefore, this statement may not apply to you.

This publication could include technical inaccuracies or typographical errors. Changes are periodically made to the information herein; these changes will be incorporated in later editions. Improvements or changes in the products or the programs described may be made at any time.

References in this publication to products, programs, or services do not imply that the manufacturer intends to make these available in all countries in which it operates. Any reference to a product, program, or service is not intended to state or imply that only that product, program, or service may be used. Any functionally equivalent product, program, or service that does not infringe any existing intellectual property right may be used instead. Evaluation and verification of operation in conjunction with other products, programs, or services, except those expressly designated by the manufacturer, are the user's responsibility.

Trademarks

Lexmark and the Lexmark logo are trademarks of Lexmark International, Inc., registered in the United States and/or other countries. PCL® is a registered trademark of the Hewlett-Packard Company. PCL is Hewlett-Packard Company's designation of a set of printer commands (language) and functions included in its printer products. This printer is intended to be compatible with the PCL language. This means the printer recognizes PCL commands used in various application programs, and that the printer emulates the functions corresponding to the commands.

PostScript is a registered trademark of Adobe Systems Incorporated in the United States and/or other countries.

All other trademarks are the property of their respective owners.

© 2017 Lexmark International, Inc.

All rights reserved.

P/N 12G2272

Table of contents

Product information.....	2
Edition notice.....	2
Notices, conventions, and safety information.....	15
Laser notice.....	15
Conventions.....	18
Safety information.....	18
General caution statements.....	24
Change history.....	25
Change history.....	25
General information.....	35
Printer model configurations.....	35
Media guidelines.....	35
Paper guidelines.....	35
Using recycled paper and other office papers.....	38
Using specialty media.....	38
Supported paper sizes, types, and weights.....	40
Data security notice.....	43
Tools required for service.....	43
Diagnostics and troubleshooting.....	45
Troubleshooting overview.....	45
Performing the initial troubleshooting check.....	45
Power-on Reset (POR) sequence.....	46
Using Safe Mode.....	46
Securing the printer.....	47
Resetting the printer without admin credentials.....	47
Using the security reset jumper.....	47
Fixing print quality issues.....	48
Initial print quality check.....	49
Gray background or toner fog check.....	50
Blank pages check.....	52
Print is too dark check.....	58
Print is too light check.....	60
Paper curl check.....	62

Folded or wrinkled paper check	64
Solid black pages check.....	65
Repeating defects check.....	68
Skewed print check	69
Streaked vertical lines appear on prints check	71
Horizontal light bands check.....	72
Vertical light bands check.....	74
Vertical dark bands check.....	75
Vertical dark streaks with print missing check	76
White streaks and voided areas check	78
Fine lines are not printed correctly (specifically Chinese characters) check	81
Clipped pages or images check.....	82
Compressed images appear on prints check.....	84
Incorrect margins on prints check	85
Toner rubs off check.....	86
Toner specks appear on prints check.....	87
Paper jams.....	89
Avoiding jams	89
Understanding jam messages and locations.....	90
200 paper jams.....	91
201 paper jams.....	101
202 paper jams.....	102
23y paper jams	105
241 paper jams	107
242–244 paper jams	112
25y paper jams	121
28y paper jams	124
29y paper jams	128
45y paper jams	129
Understanding the printer messages.....	145
Cartridge, imaging unit mismatch [41.xy].....	145
Cartridge low [88.xy].....	145
Cartridge nearly low [88.xy].....	146
Cartridge very low, [x] estimated pages remain [88.xy]	146
Change [paper source] to [custom type name] load [orientation].....	146
Change [paper source] to [custom string] load [orientation].....	146
Change [paper source] to [paper size] load [orientation]	146
Change [paper source] to [paper type] [paper size] load [orientation].....	146
Check tray [x] connection.....	147
Close front door.....	147
Close flatbed cover and load originals if restarting job [2yy.xx]	147
Complex page, some data may not have printed [39]	147
Configuration change, some held jobs were not restored [57]	148
Defective flash detected [51].....	148

Disk full [62]	148
Disk must be formatted for use in this device	148
Disk near full. Securely clearing disk space.....	148
Error reading USB drive. Remove USB.....	148
Error reading USB hub. Remove hub.....	148
Fax memory full.....	149
Fax partition inoperative. Contact system administrator.....	149
Fax server 'To Format' not set up. Contact system administrator.....	149
Fax Station Name not set up. Contact system administrator.....	149
Fax Station Number not set up. Contact system administrator.....	149
Imaging unit low [84.xy]	149
Imaging unit nearly low [84.xy]	149
Imaging unit very low, [x] estimated pages remain [84.xy].....	149
Incompatible tray [x] [59]	150
Incorrect paper size, open [paper source] [34].....	150
Insufficient memory to collate job [37].....	150
Insufficient memory for Flash Memory Defragment operation [37]	150
Insufficient memory, some Held Jobs were deleted [37].....	150
Insufficient memory, some held jobs will not be restored [37].....	150
Insufficient memory to support Resource Save feature [35].....	151
Load [paper source] with [custom type name] [paper orientation].....	151
Load [paper source] with [custom string] [paper orientation].....	151
Load [paper source] with [paper size] [paper orientation].....	151
Load [paper source] with [paper type] [paper size] [paper orientation].....	152
Load Manual Feeder with [custom type name] [paper orientation]	152
Load Manual Feeder with [custom string] [paper orientation].....	152
Load Manual Feeder with [paper size] [paper orientation].....	152
Load Manual Feeder with [paper type] [paper size] [paper orientation].....	152
Maintenance kit low [80.xy]	153
Maintenance kit nearly low [80.xy]	153
Maintenance kit very low, [x] estimated pages remain [80.xy].....	153
Memory full [38]	153
Memory full, cannot print faxes.....	153
Memory full, cannot send faxes.....	153
Network [x] software error [54].....	153
No analog phone line connected to modem, fax is disabled.....	154
Non-Lexmark [supply type], see <i>User's Guide</i> [33.xy]	154
Not enough free space in flash memory for resources [52]	154
Paper changes needed	154
Parallel port [x] disabled [56].....	155
Printer had to restart. Last job may be incomplete.	155
Remove defective disk [61]	155
Remove paper from standard output bin.....	155
Replace defective imaging unit [31.xy].....	155
Replace cartridge, 0 estimated pages remain [88.xy].....	155

Replace imaging unit, 0 estimated pages remain [84.xy].....	155
Replace maintenance kit, 0 estimated pages remain [80.xy].....	155
Replace all originals if restarting job.	156
Reinstall missing or unresponsive cartridge [31.xy].....	156
Reinstall missing or unresponsive imaging unit [31.xy].....	156
Replace unsupported cartridge [32.xy]	156
Replace unsupported imaging unit [32.xy].....	156
Restore held jobs?.....	157
Scanner automatic feeder cover open.....	157
Scanner disabled by admin [840.01]	157
Scanner disabled. Contact system administrator if problem persists. [840.02]	157
Scanner jam, remove all originals from the scanner [2yy.xx].....	157
Scanner jam, remove jammed originals from the scanner [2yy.xx].....	157
Serial port [x] disabled [56].....	157
SMTP server not set up. Contact system administrator.	157
Some held jobs were not restored	158
Standard network software error [54].....	158
Standard USB port disabled [56].....	158
Supply needed to complete job.....	158
Too many flash options installed [58].....	158
Too many trays attached [58].....	158
Unformatted flash detected [53]	159
Unsupported disk.....	159
Unsupported option in slot [x] [55]	159
USB port [x] disabled [56].....	159
Weblink server not set up. Contact system administrator.	159
User attendance messages.....	160
User attendance messages (0–99.99)	160
Unresponsive toner cartridge service check.....	163
Unsupported toner cartridge service check	163
Printer/cartridge mismatch service check	164
Unsupported imaging unit service check	164
Imaging unit smart chip contact service check	165
Toner smart chip compatibility service check.....	165
Imaging chip compatibility service check	166
Supplies mismatch service check.....	166
Flash full service check.....	167
Maintenance kit service check	167
Insufficient memory service check	167
Imaging unit low service check	168
Toner cartridge low service check.....	168
Hard disk failure service check	169
Printer hardware errors.....	170
111 errors.....	170

121 errors.....	174
126 errors.....	176
132 errors.....	177
133 errors.....	178
140 errors.....	179
146 errors.....	180
155 errors.....	181
171 errors.....	182
Procedure before starting the 9yy service checks.....	183
900 errors.....	185
912 errors.....	188
94y errors.....	189
950–958 errors.....	189
959 errors.....	192
96y errors.....	193
97y errors.....	194
98y errors.....	195
99y errors.....	196
ADF/Scanner hardware errors.....	197
8yy errors.....	197
Scan/fax/copy symptoms.....	203
Input/output option hardware errors.....	219
321–344 errors.....	219
381 errors.....	224
Other symptoms.....	224
Base printer symptoms.....	224
Dead machine service check.....	225
Controller board service check.....	226
Control panel service check.....	227
Toner starvation service check.....	228
USB print service check.....	229
Front door not closed service check.....	230
Network service check.....	231
Bin full service check.....	234
Flickering display service check.....	234
Service menus.....	235
Understanding the printer control panel.....	235
Using the printer control panel.....	235
Understanding the colors of the indicator and Sleep button lights.....	235
Understanding the home screen.....	236
Using the touch-screen buttons.....	238
Menus list.....	239

Diagnostics menu.....	240
Entering the Diagnostics menu	240
Registration	240
Scanner calibration	241
PRINT TESTS	242
Print Quality Pages.....	242
HARDWARE TESTS	243
DUPLEX TESTS	245
INPUT TRAY TESTS	247
OUTPUT BIN TESTS	248
FINISHER TESTS.....	249
BASE SENSOR TEST	249
DEVICE TESTS	250
PRINTER SETUP.....	251
EP SETUP	253
REPORTS	255
EVENT LOG.....	255
Scanner tests.....	256
Exit Diags.....	260
Configuration menu.....	261
Entering the Configuration menu.....	261
Reset ADF Maintenance Kit Counter	261
Maintenance Counter Value.....	261
Reset Maintenance Counter.....	261
Print Quality Pages.....	262
Reports	262
Panel Menus	262
PPDS Emulation	263
Download Emuls.....	263
Safe Mode	263
Factory Defaults.....	263
Energy Conserve	264
Fax low power support	264
Min copy memory.....	264
Num pad job assist.....	264
Format fax storage	265
ADF edge erase.....	265
Flatbed edge erase.....	265
Scanner manual registration	265
Disable scanner	267
Paper Prompts.....	267
Envelope Prompts	267
Action for Prompts	268
Jobs on Disk	268

Disk Encryption	269
Wipe All Settings	269
Font Density.....	269
Font Sharpening	269
Reduced Curl.....	269
Require Standby	270
A5 Loading.....	270
UI Automation.....	270
LES Applications.....	271
Key Repeat Initial Delay	271
Key Repeat Rate	271
Clear Supply Usage History.....	271
Clear Custom Status.....	272
USB Speed.....	272
Automatically Display Error Screens	272
USB PnP.....	272
Restore factory defaults.....	273
Entering Invalid engine mode.....	273
Entering Recovery mode.....	274
Accessing restore point.....	275
Accessing the Network SE menu.....	275
Service Engineer menu.....	276
Accessing the service engineer (SE) menu.....	276
Service engineer (SE) menu	276
Fax service engineer (SE) menu.....	276
Parts removal.....	277
Removal precautions.....	277
Data security notice	277
Handling ESD-sensitive parts.....	278
Controller board/control panel replacement	278
Restoring the printer configuration after replacing the controller board	279
Restoring solutions, licenses, and configuration settings	282
Updating the printer firmware	283
Backing up eSF solutions and settings	284
Ribbon cable connectors	285
Zero Insertion Force (ZIF) connectors.....	285
Horizontal top contact connector	286
Horizontal bottom contact connector	289
Vertical mount contact connector.....	292
Horizontal sliding contact connector	295
Low Insertion Force (LIF) connector	298
Printhead assembly adjustments	299

Removal procedures.....	302
Left side removals.....	302
Left cover removal	302
Main drive gearbox removal.....	304
MPF solenoid removal	306
MPF gearbox removal.....	308
Reverse solenoid removal	311
Cartridge gearbox removal.....	312
Duplex gear assembly removal.....	313
Right side removals.....	315
Right cover removal.....	315
Memory access door removal.....	318
Tray present sensor removal.....	318
Cooling fan removal.....	319
Controller board removal.....	320
Controller board shield removal.....	322
Toner cartridge smart chip contact removal	324
Modem removal.....	326
Front side removals.....	327
Left front mount removal	327
Right front mount removal	328
Transfer roll removal.....	330
Cartridge plunger removal.....	331
Name plate cover removal.....	333
Front bin cover removal.....	335
Control panel assembly removal.....	336
UICC removal	340
USB cable bracket removal	342
Speaker removal	342
Cave light lens removal	343
Interface card removal.....	344
Control panel cover removal.....	345
Display removal	346
Keypad assembly removal.....	348
MPF tray removal.....	349
MPF pick roller cover removal	352
MPF pick roller removal	352
Bail removal	353
Jam access cover removal	353
Front access cover removal	354
Front door sensor removal	356
Front input guide removal.....	356
Separator pad removal	358
Bottom side removals.....	361

Power supply removal.....	361
Power supply shield removal	361
Duplex removal.....	362
Duplex sensor and input sensor removal	363
Index sensor removal.....	366
Media present sensor removal	366
Trailing edge sensor removal.....	368
ACM assembly removal	369
Pick/lift motor gearbox removal.....	371
Tray guide removal	372
Sensor (toner density) and media present sensor flag removal.....	374
Rear side removals.....	381
Dust cover removal.....	381
Rear exit door removal.....	381
Rear cover removal.....	382
Redrive assembly removal.....	383
Redrive shaft removal.....	384
Fuser removal.....	386
Stapler cable removal	387
Diverter spring removal	389
Diverter cover removal	390
Top side removals.....	391
Top cover removal.....	391
Bin full sensor/lens removal	392
Bin full sensor cable removal	394
Laser scanning unit (LSU) removal	395
ADF/scanner removals.....	399
ADF separator roll removal	399
Flatbed cushion removal	400
Scanner front cover removal.....	401
ADF input tray removal	402
ADF unit removal.....	402
Scanner assembly removal.....	405
ADF top cover assembly removal.....	407
ADF cable removal.....	408
USB cable removal.....	409
USB wireless cable removal.....	410
ADF hinge removal	411
Flatbed assembly removal	412
Control panel ribbon cable removal.....	412
Speaker cable removal.....	412
Restraint pad removal	414
550-sheet option tray removals.....	415
Pick roller removal.....	415

Separator roll assembly removal.....	416
ACM assembly removal.....	418
Staple finisher option removals.....	421
Staple finisher option removal.....	421
Stapler cartridge access door removal.....	422
Staple roll holder removal.....	423
Stapler right cover removal.....	424
Stapler left cover removal.....	425
Stapler rear door removal.....	426
Sensor (stapler access door) removal.....	427
Stapler carriage assembly removal.....	427
Stapler door close limit switch removal.....	429
Stapler paddle motor removal.....	433
Stapler rear cover removal.....	433
Sensor (stapler rear cover) removal.....	434
Trapped staple access door removal.....	436
Stapler service cover removal.....	437
Stapler controller card removal.....	437
Stapler left tamper motor removal.....	437
Stapler right tamper motor removal.....	438
Stapler rear cover close limit switch removal.....	439
Stapler cooling fan removal.....	441
Stapler power supply unit removal.....	441
Stapler interface cable removal.....	443
Stapler top cover removal.....	445
Sensor (stapler bin full receive) removal.....	448
Sensor (stapler bin full send) removal.....	450
Sensor (stapler pass through) removal.....	453
Tamper main assembly removal.....	455
Tamper sub-assembly removal.....	456
Tamper drive belt removal.....	458
Diverter gearbox removal.....	459
Stapler accumulator assembly removal.....	462
Sensor (stapler right tamper HP) removal.....	462
Sensor (stapler left tamper HP) removal.....	463
Sensor (stapler paddle HP) removal.....	464
Component locations.....	467
Exterior locations.....	467
Front view.....	467
Rear view.....	468
Connectors.....	469
Controller board.....	469
Power supply.....	477

Maintenance.....	479
Inspection guide.....	479
Scheduled maintenance.....	480
Maintenance kits.....	480
Resetting the maintenance counter	480
Lubrication specification.....	481
Cleaning the printer.....	481
Cleaning the printer	481
Cleaning the scanner glass	482
Cleaning the printhead lenses.....	483
Parts catalog.....	484
Legend.....	484
Assembly 1: Covers.....	485
Assembly 2: Imaging.....	487
Assembly 3: Control panel.....	489
Assembly 4: Electronics 1.....	491
Assembly 5: Electronics 2.....	495
Assembly 6: Frame.....	498
Assembly 7: Option trays.....	501
Assembly 8: Staple finisher option.....	503
Assembly 9: Staple finisher (right).....	505
Assembly 10: Staple finisher (top).....	507
Assembly 11: Staple finisher (rear).....	509
Assembly 12: Staple finisher exit assembly.....	511
Assembly 13: Staple finisher tamper assembly.....	513
Assembly 14: Staple finisher accumulator assembly.....	515
Assembly 15: Maintenance kits.....	517
Assembly 16: Power cords.....	519
Assembly 17: Miscellaneous.....	521
Printer specifications.....	523
Electrical specifications.....	523
Applicability of Regulation (EU) 2019/2015 and (EU) 2019/2020.....	523
Operating clearances.....	523
Acoustics.....	524
Operating environment.....	524

Scanner specifications.....	524
Fax specifications.....	525
Options and features.....	527
Available internal options.....	527
Media handling options.....	527
Theory of operation.....	529
POR sequence.....	529
Printer control.....	529
Paper path information.....	529
Input tray	529
Multipurpose feeder (MPF)	530
Simplex printing	530
Duplex printing.....	531
Media handling components.....	532
Main drive gearbox	532
Autocompensator mechanism (ACM)	532
Key components.....	533
Sensors	533
Other key components	534
Electrophotographic process (EP process).....	536
ADF theory.....	539
ADF theory of operation.....	539
Acronyms.....	543
Acronyms.....	543
Index.....	545
Part number index.....	555
Part name index.....	561

Notices, conventions, and safety information

Laser notice

The printer is certified in the U.S. to conform to the requirements of DHHS 21 CFR, Chapter I, Subchapter J for Class I (1) laser products, and elsewhere is certified as a Class I laser product conforming to the requirements of IEC 60825-1: 2014.

Class I laser products are not considered to be hazardous. The printer contains a Class IIIb (3b) laser that is nominally a 12-milliwatt gallium arsenide laser operating in the wavelength of 655–675 nanometers. The laser system and printer are designed so there is never any human access to laser radiation above a Class I level during normal operation, user maintenance, or prescribed service condition.

Avis relatif à l'utilisation du laser

Cette imprimante est certifiée conforme aux exigences de la réglementation des Etats-Unis relative aux produits laser de classe I (1) (DHHS 21 CFR, Chapitre I, Sous-chapitre J). Pour les autres pays, elle est certifiée conforme aux exigences des normes CEI 60825-1:2014 relatives aux produits laser de classe I.

Les produits laser de classe I ne sont pas considérés comme dangereux. L'imprimante contient un laser de classe IIIb (3b), laser arséniure de gallium 12 milliwatts opérant sur une longueur d'onde de l'ordre de 655 à 675 nanomètres. Le système laser ainsi que l'imprimante ont été conçus de manière à ce que personne ne soit exposé à des rayonnements laser dépassant le niveau de classe I dans le cadre d'un fonctionnement normal, de l'entretien par l'utilisateur ou de la maintenance.

Notificació del làser

La impressora està certificada als EUA per complir els requeriments de DHHS 21 CFR, capítol I, subcapítol J per a productes de làser Classe I (1), i a la resta del món s'ha certificat com productes de làser Classe I segons els requeriments de la norma IEC 60825-1: 2014.

Els productes de làser Classe I no es consideren perillosos. La impressora conté un làser intern Classe IIIb (3b) que normalment és un arsenur de galió de 12 miliwatts, que funciona a la regió de longitud d'ona de 655 a 675 nanòmetres i es troba dins d'una unitat de capçals d'impressió no substituïbles. El sistema làser i la impressora estan dissenyats de manera que les persones no estiguin exposades a una radiació del làser superior al nivell de Classe I durant el funcionament normal, el manteniment de l'usuari o les condicions de servei prescrites.

Aviso de láser

Esta impresora se ha certificado en EE.UU. cumpliendo con los requisitos de DHHS 21 CFR, capítulo I, subcapítulo J para los productos láser de Clase I (1) y en otros países está certificada como un producto láser de Clase I de acuerdo con los requisitos de IEC 60825-1: 2014.

Los productos láser de Clase I no se consideran peligrosos. La impresora contiene un láser interno de Clase IIIb (3b) que nominalmente es un láser de arsenide galio de 12 milivatios que funciona en una longitud de onda de 655-675 nanómetros. El sistema láser y la impresora se han diseñado para que el ser humano no acceda nunca a las radiaciones láser por encima del nivel de Clase I durante su uso normal, ni en tareas de mantenimiento o intervenciones de servicio técnico prescrites.

Aviso sobre laser

Esta impressora foi certificada nos EUA por estar em conformidade com os requisitos do DHHS 21 CFR capítulo I, subcapítulo J, para produtos a laser de Classe I (1) e, nos demais países, foi certificada como um produto a laser de Classe I em conformidade com os requisitos da IEC 60825-1: 2014.

Os produtos a laser de Classe I não são considerados prejudiciais. A impressora contém, internamente, um laser de Classe IIIb (3b) que é, nominalmente, um laser de arsenieto de gálio de 12 miliwatts operando no comprimento de onda de 655-675 nanômetros. O sistema do laser e a impressora foram projetados para que jamais haja acesso humano à radiação do laser acima do nível da Classe I durante a operação normal ou a manutenção pelo usuário ou sob as condições de manutenção prescritas.

Avvertenze sui prodotti laser

La stampante è certificata negli Stati Uniti come prodotto conforme ai requisiti DHHS 21 CFR Capitolo I, Sottocapitolo J per i prodotti laser di Classe I (1), mentre in altri paesi è certificata come prodotto laser di Classe I conforme ai requisiti IEC 60825-1: 2014.

I prodotti laser di Classe I non sono considerati pericolosi. La stampante contiene un laser di Classe IIIb (3b), che è nominalmente un laser ad arseniuro di gallio a 12 milliwatt funzionante a una lunghezza d'onda di 655-675 nanometri. Il sistema laser e la stampante sono stati progettati in modo da impedire l'esposizione a radiazioni laser superiori al livello previsto dalla Classe I durante le normali operazioni di stampa, manutenzione o assistenza.

Laserinformatie

De printer is in de Verenigde Staten gecertificeerd als een product dat voldoet aan de vereisten van DHHS 21 CFR hoofdstuk 1, paragraaf J voor laserproducten van klasse I (1). Elders is de printer gecertificeerd als een laserproduct van klasse I dat voldoet aan de vereisten van IEC 60825-1: 2014.

Laserproducten van klasse I worden geacht geen gevaar op te leveren. De printer bevat een interne laser van klasse IIIb (3b); een galliumarsenide laser met een nominaal vermogen van 12 milliwatt en een golflengtebereik van 655-675 nanometer. Het lasersysteem en de printer zijn zodanig ontworpen dat gebruikers nooit blootstaan aan laserstraling die hoger is dan het toegestane niveau voor klasse I-apparaten, tijdens normaal gebruik, onderhoudswerkzaamheden door de gebruiker of voorgeschreven servicewerkzaamheden.

Lasererklæring

Printeren er certificeret i USA i henhold til kravene i DHHS 21 CFR kapitel I, underafsnit J for klasse I (1)-laserprodukter og er andre steder certificeret som et klasse I laserprodukt i henhold til kravene i IEC 60825-1: 2014.

Klasse I-laserprodukter anses ikke som farlige. Printeren indeholder internt en klasse IIIb (3b)-laser, der nominelt er en 12 milliwatt galliumarsenid-laser, som fungerer i bølglængdeområdet 655-675 nanometer. Lasersystemet og printeren er udviklet på en sådan måde, at der ikke er en direkte laserstråling, der overskrider Klasse I-niveauet under normal brug, brugers vedligeholdelse eller de foreskrevne servicebetingelser.

Laser-Hinweis

Der Drucker wurde in den USA zertifiziert und entspricht den Anforderungen der Vorschriften DHHS 21 CFR Kapitel I für Laserprodukte der Klasse I (1), andernorts ist er als Laserprodukt der Klasse I zertifiziert, das den Anforderungen von IEC 60825-1 entspricht: 2014.

Laserprodukte der Klasse I werden nicht als gefährlich betrachtet. Der Drucker enthält im Inneren einen Laser der Klasse IIIb (3b), und zwar einen 12-Milliwatt-Gallium-Arsenid-Laser, der im Wellenlängenbereich von 655 bis 675 Nanometern arbeitet. Das Lasersystem und der Drucker sind so konstruiert, dass unter normalen Betriebsbedingungen, bei der Wartung durch den Benutzer oder bei den vorgeschriebenen Wartungsbedingungen Menschen keiner Laserstrahlung ausgesetzt sind, die die Werte für Klasse I überschreitet.

Laserilmoitus

Tämä tulostin on sertifioitu Yhdysvalloissa DHHS 21 CFR Chapter I, Subchapter J -standardin mukaiseksi luokan I (1) -lasertuotteeksi ja muualla IEC 60825-1:2014 -standardin mukaiseksi luokan I lasertuotteeksi.

Luokan I lasertuotteita ei pidetä haitallisina. Tulostimen sisällä on luokan IIIb (3b) laser, joka on nimellistehoaltaan 12 mW:n galliumarsenidilaser ja toimii 655–675 nanometrin aallonpituuksilla. Laserjärjestelmä ja tulostin ovat rakenteeltaan sellaisia, että käyttäjä ei joudu alttiiksi luokkaa 1 suuremmalle säteilylle normaalin käytön, ylläpidon tai huollon aikana.

Lasermerknad

Skriveren er sertifisert i USA for samsvar med kravene i DHHS 21 CFR kapittel I, underkapittel J for laserprodukter av klasse I (1) og er andre steder sertifisert som et laserprodukt av klasse I som samsvarer med kravene i IEC 60825-1: 2014.

Laserprodukter av klasse I anses ikke som helseskadelige. Skriveren inneholder en intern laser av klasse IIIb (3b) som nominelt er en 12 milliwatt galliumarsenid-laser som opererer i bølgelengder på 655–675 nanometer. Lasersystemet og skriveren er utformet slik at mennesker ikke utsettes for laserstråling utover nivået i klasse I under normal drift, vedlikehold eller foreskrevet service.

Meddelande om laser

Skrivaren är certifierad i USA i enlighet med kraven i DHHS 21 CFR kapitel I, underkapitel J för klass I (1)-laserprodukter, och på andra platser certifierad som en klass I-laserprodukt i enlighet med kraven i IEC 60825-1: 2014.

Laserprodukter av klass I anses inte vara skadliga. Skrivaren innehåller en klass IIIb (3b)-laser, vilket är en 12 mW galliumarseniklaser som arbetar inom en våglängd på 655–675 nm. Lasersystemet och skrivaren är utformade så att människor aldrig utsätts för laserstrålning över klass I-nivå under normala förhållanden vid användning, underhåll eller service.

レーザーについて

本機は、米国においてクラス I (1) レーザー製品に対する DHHS 21 CFR Chapter I、Subchapter J の要件に準拠し、その他の国では IEC 60825-1: 2014 の要件に準拠するクラス I レーザー製品として認可されています。

クラス I レーザー製品は、危険性がないとみなされています。本機には、クラス IIIb (3b) レーザーが内蔵されています。これは、655 ~ 675 ナノメートルの波長で動作する定格 12 ミリワットのガリウムヒ素レーザーです。レーザーシステムとプリンタは、通常の操作、ユーザによるメンテナンス、または所定のサービス条件の下で、ユーザがクラス I レベルを超えるレーザー放射に絶対にさらされないように設計されています。

레이저 고지사항

프린터는 미국에서 레이저 제품용 DHHS 21 CFR Chapter I, Subchapter J의 요구 사항을 준수하며 이외 지역에서 IEC 60825-1:2014의 요구 사항을 준수하는 클래스 I(1) 레이저 제품으로 승인되었습니다.

클래스 I 레이저 제품은 위험한 제품으로 간주되지 않습니다. 프린터에는 655-675 나노미터의 파장 영역에서 작동하는 공칭 12밀리와트 갈륨 비소 레이저인 클래스 IIIb(3b) 레이저가 내부에 포함되어 있습니다. 레이저 시스템과 프린터는 정상적인 작동, 사용자 유지 관리 또는 사전 설명된 서비스 조건에는 사람에게 클래스 I 수준 이상의 레이저 방사가 노출되지 않도록 설계되었습니다.

激光注意事项

本打印机在美国认证合乎 DHHS 21 CFR Chapter I, Subchapter J 对分类 I (1) 激光产品的标准, 而在其他地区则被认证是合乎 IEC 60825-1: 2014 的分类 I 激光产品。

一般认为分类 I 激光产品不具有危险性。本打印机内部含有分类 IIIb (3b) 的激光, 是标称值为 12 毫瓦的砷化镓激光, 其工作波长范围在 655–675nm 之间。本激光系统及打印机的设计, 在一般操作、使用者维护或规定内的维修情况下, 不会使人体接触分类 I 以上等级的辐射。

雷射聲明

本印表機係經過美國核可, 符合 DHHS 21 CFR, Chapter I, Subchapter J 規定的 I (1) 級雷射產品; 在美國以外的地區, 為符合 IEC 60825-1 2014 規定的 I 級雷射產品。

根據 I 級雷射產品的規定, 這類產品不會對人體造成傷害。本印表機內部所採用之 IIIb (3b) 級雷射只會產生 12 毫瓦特 (milliwatt)、波長 655 至 675 奈米 (nanometer) 的鎵砷放射線 (gallium arsenide laser)。使用者只要以正確的方法操作及維護保養, 並依照先前所述之維修方式進行修護, 此印表機與其雷射系統絕不會產生 I 級以上的放射線, 而對人體造成傷害。

Conventions

Note: A *note* identifies information that could help you.

Warning: A *warning* identifies something that could damage the product hardware or software.

CAUTION: A *caution* indicates a potentially hazardous situation that could injure you.

Different types of caution statements include:



CAUTION—POTENTIAL INJURY: Indicates a risk of injury.



CAUTION—SHOCK HAZARD: Indicates a risk of electrical shock.



CAUTION—HOT SURFACE: Indicates a risk of burn if touched.



CAUTION—TIPPING HAZARD: Indicates a crush hazard.





CAUTION—PINCH HAZARD: Indicates a risk of being caught between moving parts.

Safety information

- The safety of this product is based on testing and approvals of the original design and specific components. The manufacturer is not responsible for safety in the event of use of unauthorized replacement parts.
- The maintenance information for this product has been prepared for use by a professional service person and is not intended to be used by others.

- There may be an increased risk of electrical shock and personal injury during disassembly and servicing of this product. Professional service personnel should understand this risk and take necessary precautions.

 **CAUTION—SHOCK HAZARD:** When you see this symbol, there is a danger from hazardous voltage in the area of the product where you are working. Unplug the product before you begin, or use caution if the product must receive power in order to perform the task.

 **CAUTION—POTENTIAL INJURY:** The lithium battery in this product is not intended to be replaced. There is a danger of explosion if a lithium battery is incorrectly replaced. Do not recharge, disassemble, or incinerate a lithium battery. Discard used lithium batteries according to the manufacturer's instructions and local regulations.

Consignes de sécurité

- La sécurité de ce produit est basée sur des tests et certifications de sa conception d'origine et de ses composants spécifiques. Le fabricant décline toute responsabilité en cas d'utilisation de pièces de rechange non autorisées.
- Les informations de maintenance de ce produit sont destinées à des professionnels qualifiés et ne sont pas conçues pour être utilisées par d'autres personnes.
- Il existe un risque potentiel de choc électrique et de blessures lors du démontage et de la maintenance de ce produit. Le personnel professionnel de maintenance doit comprendre les risques et prendre les précautions nécessaires.

 **ATTENTION—RISQUE D'ELECTROCUTION :** Ce symbole indique un danger lié à des niveaux de tension dangereux dans la zone du produit à manipuler. Débranchez le produit avant de commencer, ou agissez avec prudence si le produit doit être alimenté pour effectuer l'opération.

 **ATTENTION—RISQUE DE BLESSURE :** La batterie lithium de ce produit n'est pas destinée à être remplacée. Si vous ne respectez pas les instructions de remplacement de la batterie, vous risquez de provoquer une explosion. Ne rechargez pas, ne désassemblez pas et ne brûlez pas la batterie au lithium. Mettez les batteries lithium usagées au rebut selon les instructions du fabricant et les réglementations locales.

Informació de seguretat

- La seguretat d'aquest producte es basa en les proves i les homologacions del disseny original i dels components específics. El fabricant no és responsable de la seguretat en el cas d'ús de peces de recanvi no autoritzades.
- La informació de manteniment d'aquest producte s'ha preparat per a l'ús d'un professional tècnic i no per a l'ús d'altres persones.
- És possible que el risc de descàrrega elèctrica i lesions personals augmenti durant el desmuntatge i les tasques de manteniment d'aquest producte. El professional tècnic ha de comprendre aquest risc i prendre les precaucions necessàries.

 **PRECAUCIÓ. PERILL DE DESCÀRREGA ELÈCTRICA:** Quan vegeu aquest símbol, indica que hi ha un perill de voltatge elevat en l'àrea del producte on esteu treballant. Desconnecteu el producte abans de començar o tingueu precaució si el producte ha de rebre alimentació per realitzar la tasca.

 **PRECAUCIÓ. POSSIBLES DANYS:** La bateria de liti d'aquest producte no ha estat dissenyada perquè se substitueixi. Hi ha perill d'explosió si no es substitueix correctament la bateria de liti. No recarregueu, desmunteu o incinereu una bateria de liti. Desfeu-vos de les bateries de liti usades d'acord amb les instruccions del fabricant i les regulacions locals.

Información de seguridad

- La seguridad de este producto se basa en las pruebas y comprobaciones del diseño original y los componentes específicos. El fabricante no se hace responsable de la seguridad en caso de uso de piezas de repuesto no autorizadas.
- La información de mantenimiento de este producto se ha preparado para su uso por parte de un profesional de asistencia técnica y no está diseñada para su uso por parte de otros usuarios.
- Es posible que haya un mayor riesgo de descarga eléctrica y daños personales durante el desmontaje y el mantenimiento de este producto. El personal de asistencia profesional debe conocer este riesgo y tomar las precauciones necesarias.

 **PRECAUCIÓN: PELIGRO DE DESCARGAS ELÉCTRICAS:** Cuando vea este símbolo, existe peligro de tensiones peligrosas en el área del producto en la que está trabajando. Desconecte el producto antes de empezar o tenga cuidado si el producto debe recibir alimentación a fin de realizar la tarea.

 **PRECAUCIÓN: POSIBLES DAÑOS PERSONALES:** La batería de litio de este producto no debe reemplazarse. Existe riesgo de explosión si se sustituye incorrectamente una batería de litio. No recargue, desmonte ni incinere una batería de litio. Deseche las baterías de litio usadas según las instrucciones del fabricante y las normativas locales.

Informações sobre segurança

- A segurança deste produto é baseada em testes e aprovações do design original e de componentes específicos. O fabricante não é responsável por segurança em caso de uso não autorizado de peças de substituição.
- As informações sobre manutenção deste produto foram preparadas para utilização por um técnico profissional experiente e não se destinam ao uso por outros.
- Pode haver maior risco de choque elétrico e danos pessoais durante a desmontagem e manutenção deste produto. Os técnicos profissionais experientes devem entender esses riscos e tomar as precauções necessárias.

 **ATENÇÃO—RISCO DE CHOQUE:** Se você vir este símbolo, existe perigo de tensão elétrica na área do produto onde está trabalhando. Desligue o produto antes de começar ou tenha cuidado se o produto precisar receber energia para executar a tarefa.

 **ATENÇÃO—RISCO DE FERIMENTO:** A bateria de lítio neste produto não deve ser substituída. Existe o risco de explosão se uma bateria de lítio for substituída incorretamente. Não recarregue, desmonte nem incinere uma bateria de lítio. Descarte as baterias de lítio usadas de acordo com as instruções do fabricante e regulamentos locais.

Informazioni sulla sicurezza

- La sicurezza di questo prodotto è basata sui test e sulle approvazioni del design originale e dei componenti specifici. Il produttore non è responsabile della sicurezza in caso di utilizzo di parti di ricambio non autorizzate.
- Le informazioni di manutenzione per questo prodotto sono state predisposte per essere utilizzate da un tecnico dell'assistenza professionale e non sono state previste per l'uso da parte di altre persone.
- È possibile che vi sia un maggior rischio di scosse elettriche e lesioni personali durante lo smontaggio e la manutenzione di questo prodotto. Il personale dell'assistenza deve comprendere questo rischio e prendere le precauzioni necessarie.

 **ATTENZIONE - PERICOLO DI SCOSSE ELETTRICHE:** Questo simbolo indica la presenza di un rischio per tensioni pericolose nell'area del prodotto in cui si lavora. Scollegare l'alimentazione prima di iniziare, o prestare la massima attenzione se per effettuare l'operazione il prodotto deve ricevere l'alimentazione.

 **ATTENZIONE - PERICOLO DI LESIONI:** La batteria al litio contenuto nel prodotto non deve essere sostituita: in caso di sostituzione errata della batteria al litio, potrebbe verificarsi un'esplosione. Non ricaricare, smontare o bruciare batterie al litio. Smaltire le batterie al litio usate seguendo le istruzioni del produttore e le norme locali.

Informatie over veiligheid

- De veiligheid van dit product is gebaseerd op testen en goedkeuringen van het oorspronkelijke ontwerp en specifieke onderdelen. De fabrikant is niet verantwoordelijk voor de veiligheid bij gebruik van ongeautoriseerde vervangende onderdelen.
- De informatie over het onderhoud van dit product is opgesteld voor gebruik door een professionele onderhoudsmonteur en is niet bedoeld voor gebruik door anderen.
- Tijdens demontage en onderhoud van dit product bestaat mogelijk een hoger risico op elektrische schokken en lichamelijk letsel. Professionele onderhoudsmonteurs dienen op de hoogte te zijn van dit risico en de noodzakelijke voorzorgsmaatregelen te nemen.

 **LET OP: GEVAAR VOOR ELEKTRISCHE SCHOKKEN:** Wanneer u dit symbool ziet, bestaat er een gevaar voor gevaarlijke spanning in het gebied van het product waaraan u werkt. Haal de stekker van het product uit het stopcontact voordat u begint, of let extra goed op als het product stroom nodig heeft om een taak te kunnen uitvoeren.

 **LET OP: RISICO OP LETSEL:** De lithiumbatterij in dit product moet niet worden vervangen. Wanneer de lithiumbatterij niet juist wordt vervangen, bestaat er explosiegevaar. Probeer nooit lithiumbatterijen op te laden, open te maken of te verbranden. Gooi gebruikte lithiumbatterijen weg volgens de aanwijzingen van de fabrikant en houd hierbij de plaatselijke regelgeving in acht.

Sikkerhedsoplysninger

- Sikkerheden for dette produkt er baseret på afprøvning og godkendelser af det oprindelige design og specifikke komponenter. Producenten er ikke ansvarlig for sikkerhed i tilfælde af brug af uautoriserede dele til udskiftning.
- Vedligeholdelsesoplysninger om dette produkt er udarbejdet til brug af en kvalificeret servicetekniker og er ikke beregnet til at blive brugt af andre.
- Der kan være en forøget risiko for elektrisk stød eller personskade ved afmontering og service af dette produkt. Professionelt servicepersonale bør forstå denne risiko og tage nødvendige forholdsregler.

 **FORSIGTIG - ELEKTRISK STØD:** Når du ser dette symbol, er der risiko for elektrisk spænding i nærheden af produktet, hvor du arbejder. Tag strømskiftet ud inden du begynder, eller udvis forsigtighed, hvis produktet skal modtage strøm for at udføre opgaven.

 **FORSIGTIG - RISIKO FOR SKADE:** Litium-batteriet i dette produkt er ikke beregnet til at blive udskiftet. Der er fare for eksplosion, hvis et litium-batteri udskiftes forkert. Du må ikke genoplade, demontere eller afbrænde et litium-batteri. Brugte litium-batterier skal bortskaffes i overensstemmelse med producentens instruktioner og lokale retningslinjer.

Sicherheitshinweise

- Die Sicherheit dieses Produkts basiert auf Tests und Zulassungen des Originaldesigns und der spezifischen Komponenten. Sofern nicht autorisierte Ersatzteile eingesetzt werden, übernimmt der Hersteller keinerlei Verantwortung in Bezug auf die Sicherheit dieses Produkts.
- Die Wartungsinformationen für dieses Produkt wurden für ausgebildete Servicemitarbeiter zusammengestellt und dürfen nicht von anderen verwendet werden.
- Möglicherweise besteht bei der Demontage und Wartung dieses Produkts eine erhöhte Stromschlag- und Verletzungsgefahr. Ausgebildete Servicemitarbeiter sollten sich dieser Gefahr bewusst sein und die notwendigen Vorsichtsmaßnahmen ergreifen.

 **VORSICHT – STROMSCHLAGGEFAHR:** Wenn Sie dieses Symbol sehen, besteht eine Gefahr durch gefährliche Spannungen in dem Produktbereich, in dem Sie arbeiten. Trennen Sie das Produkt von seiner Stromverbindung, bevor Sie beginnen, oder gehen Sie vorsichtig vor, wenn das Produkt für die Durchführung der Aufgabe mit Strom versorgt werden muss.

 **VORSICHT – MÖGLICHE VERLETZUNGSGEFAHR** Die Lithiumbatterie in diesem Produkt darf nicht ausgetauscht werden. Wird eine Lithiumbatterie nicht ordnungsgemäß ausgetauscht, besteht Explosionsgefahr. Lithiumbatterien dürfen auf keinen Fall wieder aufgeladen, auseinander genommen oder verbrannt werden. Befolgen Sie zum Entsorgen verbrauchter Lithiumbatterien die Anweisungen des Herstellers und die örtlichen Bestimmungen.

Turvallisuusohjeet

- Tämän laitteen turvallisuus perustuu alkuperäisen rakenteen ja tiettyjen osien testaukseen ja hyväksymiseen. Valmistaja ei vastaa turvallisuudessa, jos laitteessa on käytetty luvattomia vaihto-osia.
- Tämän tuotteen huoltoa koskevat tiedot on tarkoitettu vain ammattitaitoisen huoltohenkilön käyttöön.
- Tämän tuotteen purkamiseen ja huoltoon voi liittyä kasvanut sähköiskun tai henkilövahingon vaara. Ammattitaitoisen huoltohenkilön on ymmärrettävä tämä vaara ja toimittava sen edellyttämällä tavalla.

 **HUOMIO – SÄHKÖISKUN VAARA:** Tämä symboli ilmaisee, että tuotteen työskentelyalueella on olemassa vaarallinen jännite. Irrota laite verkkovirrasta ennen kuin aloitat tai toimi erittäin varovasti, jos laitteessa on oltava virta työn aikana.

 **HUOMIO – TAPATURMAN MAHDOLLISUUS:** Tuotteessa olevaa litiumakkua ei ole tarkoitettu vaihdettavaksi. Litiumakun poistaminen väärin aiheuttaa räjähdysvaaran. Älä lataa, pura tai polta litiumakkua. Hävitä käytetyt litiumakut valmistajan ohjeiden ja paikallisten säädösten mukaisesti.

Sikkerhetsinformasjon

- Sikkerheten til dette produktet er basert på testing og godkjenning av originaldesignet og bestemte komponenter. Produsenten er ikke ansvarlig for sikkerheten ved bruk av uautoriserte reservedeler.
- Vedlikeholdsinformasjonen for dette produktet er tilrettelagt for bruk av profesjonelt servicepersonale, og er ikke ment for bruk av andre.
- Det kan være en økt risiko for elektrisk støt og personskade under demontering og vedlikehold av produktet. Profesjonelt servicepersonell må være innforstått med denne risikoen og ta nødvendige forholdsregler.

 **FORSIKTIG – FARE FOR STØT:** Dette symbolet betyr at det er fare for farlig spenning i det området av produktet der du arbeider. Koble fra produktet før du begynner, eller vær forsiktig hvis produktet må ha strøm for å kunne utføre oppgaven.

-  **FORSIKTIG – POTENSIELLE SKADER:** Litiumbatteriet i dette produktet er ikke beregnet for å byttes. Det er fare for eksplosjon hvis litiumbatteriet skiftes ut på feil måte. Ikke lad opp, demonter eller destruer et litiumbatteri. Kast brukte litiumbatterier i henhold til produsentens instruksjoner og lokale regelverk.

Säkerhetsinformation

- Säkerheten för denna produkt baseras på tester och godkännanden av ursprungsdesignen och av specifika komponenter. Tillverkaren har inget ansvar vid användning av oauktoriserade reservdelar.
- Underhållsinformationen för produkten är avsedd att användas av utbildade servicetekniker och inte avsedd att användas av andra.
- Risken för elektriska stötar och personskador kan vara förhöjd vid isärtagning och service av produkten. Professionell servicepersonal bör vara medvetna om denna risk och vidta nödvändiga försiktighetsåtgärder.

-  **VAR FÖRSIKTIG– RISK FÖR ELEKTRISK STÖT:** När du ser denna symbol är det risk att det finns farlig spänning i den del av produkten du arbetar med. Koppla från strömmen innan du börjar, eller var försiktig om produkten måste vara strömförsörjd för att uppgiften ska kunna utföras.

-  **VAR FÖRSIKTIG – RISK FÖR SKADA:** Litiumbatteriet i produkten är inte utbytbart. Om ett litiumbatteri byts ut på fel sätt finns det risk att det exploderar. Du får inte ladda om, ta isär eller elda upp ett litiumbatteri. Gör dig av med använda litiumbatterier enligt tillverkarens instruktioner och lokala föreskrifter.

安全情報

- 本製品の安全性は、本来の設計、特定コンポーネントの試験、承認に基づいています。承認されていない交換部品をお客様が使用した場合、メーカーは安全性に対して責任を負いません。
- 本製品のメンテナンス情報は、専門のサービス担当者による利用を目的としており、その他の人を対象としていません。
- 本製品の分解や保守サービスを行う場合は、感電や傷害の危険性があります。専門のサービス担当者はこの危険性を理解し、十分な対策を講じる必要があります。

-  **注意—感電危険:** この表記がある場合、対象製品の作業領域には、高電圧による危険性が生じています。作業を始める前に、製品から電源コードを取り外してください。また作業時に、製品に給電する必要がある場合は、十分に注意するようにしてください。

-  **注意—傷害の恐れあり:** この製品に使用されているリチウム電池は、交換を前提としていません。リチウム電池の交換を誤ると破裂する危険性があります。リチウム電池の充電、解体、焼却はしないでください。使用済みのリチウム電池を廃棄する際は、製造元の指示およびお使いの地域の法律に従ってください。

안전 정보

- 이 제품의 안전은 기본 디자인 및 특정 구성품의 승인 및 테스트를 기반으로 합니다. 제조업체는 권한 없는 교체 부품 사용 시 안전에 대해 책임을 지지 않습니다.
- 이 제품의 유지관리 정보는 전문 서비스 요원을 대상으로 하며 다른 사람은 사용할 수 없습니다.
- 제품 분해 및 서비스 중에는 감전 및 상해 위험이 증가할 수 있습니다. 전문 서비스 요원은 이와 같은 위험을 이해하고 필요한 예방 조치를 취해야 합니다.

-  **주의—감전 위험:** 이 기호가 표시된 경우 작업 중인 제품 주변에서 위험 전압 위험이 있습니다. 사용 전/후에 전원 코드를 뽑아 두시고 제품에서 작업을 수행하는 데 반드시 전원이 필요한 경우에는 주의하여 사용하십시오.

-  **주의—상해 위험:** 이 제품에 들어 있는 리튬 배터리는 교체할 수 없습니다. 리튬 배터리를 잘못 교체하면 폭발할 위험이 있습니다. 리튬 배터리를 충전, 분해하거나 불에 태우지 마십시오. 제조업체의 지침과 지역 규정에 따라 다 쓴 리튬 배터리를 폐기하십시오.

安全信息

- 本产品的安全性以原始设计和特定组件的测试和审批为基础。如果使用未经授权的替换部件，制造商不对安全性负责。
- 本产品的维护信息仅供专业服务人员使用，并不打算由其他人使用。
- 本产品在拆卸和维修时，遭受电击和人员受伤的危险性会增高。专业服务人员对这点必须有所了解，并采取必要的预防措施。

 **小心—电击危险:** 当您看到此符号时，在您工作的产品区域内存在危险电压的威胁。在您开始操作之前请拔掉产品电源，如果产品必须接收功率才能执行任务，请务必谨慎操作。

 **小心—可能的伤害:** 本产品中的锂电池不可更换。如果不正确更换锂电池，可能会有爆炸危险。不要再充电、拆解或焚烧锂电池。丢弃旧的锂电池时应按照制造商的指导及当地法规进行处理。

安全資訊

- 本產品安全性係以原始設計及特定元件之測試與核准為依據。如有使用未獲授權替換組件之情形者，製造商對安全性概不負責。
- 本產品之維護資訊僅供專業維修人員使用，而非預定由他人使用。
- 拆裝及維修本產品時，有可能造成電擊與人員損傷之危險。專業維修人員應瞭解前項危險並採取必要措施。

 **請當心—觸電危險:** 當您看到此符號時，表示您所在產品工作區有危險電壓。開始工作之前，請先拔掉產品電源線，若產品必須接上電源方能執行作業，用電時請務必小心。

 **請當心—潛在受傷危險性:** 本產品中的鋰電池原本並不需要予以更換。若未正確更換鋰電池，可能會有爆炸的危險。請勿將鋰電池充電、拆裝或焚燒。請遵照製造商的指示及當地法規，丟棄用過的電池。

General caution statements

 **CAUTION—POTENTIAL INJURY:** To avoid the risk of fire or electrical shock, connect the power cord to an appropriately rated and properly grounded electrical outlet that is near the product and easily accessible.

 **CAUTION—POTENTIAL INJURY:** To avoid the risk of fire or electrical shock, use only the power cord provided with this product or the manufacturer's authorized replacement.

 **CAUTION—POTENTIAL INJURY:** Do not use this product with extension cords, multioutlet power strips, multioutlet extenders, or UPS devices. The power capacity of these types of accessories can be easily overloaded by a laser printer and may result in a risk of fire, property damage, or poor printer performance.

 **CAUTION—POTENTIAL INJURY:** Only a Lexmark Inline Surge Protector that is properly connected between the printer and the power cord provided with the printer may be used with this product. The use of non-Lexmark surge protection devices may result in a risk of fire, property damage, or poor printer performance.

Change history

Change history

January 4, 2023

- Added the topic group Securing the printer in the Diagnostics and troubleshooting chapter. It includes these topics:
 - Resetting the printer without admin credentials. See [“Resetting the printer without admin credentials” on page 47.](#)
 - Using the security reset jumper. See [“Using the security reset jumper” on page 47.](#)

August 24, 2022

- Added a video link in the Sensor (toner density) and media present sensor flag removal topic in the Parts removal chapter. See [“Sensor \(toner density\) and media present sensor flag removal” on page 374.](#)

August 23, 2022

- Updated the Entering recovery mode topic in the Service menus chapter. See [“Entering Recovery mode” on page 274.](#)

August 18, 2022

- Updated the Sensor (toner density) and media present sensor flag removal topic in the Parts removal chapter. See [“Sensor \(toner density\) and media present sensor flag removal” on page 374.](#)
- Updated the graphic in the Electronics 2 assembly in the Parts catalog chapter. See [“Electronics 2” on page 495.](#)

July 12, 2022

- Added the flickering display symptom service check in the Diagnostics and troubleshooting chapter. See [“Flickering display service check” on page 234.](#)

May 27, 2022

- Added the PN 40X9879 (Smart card reader) in the Miscellaneous assembly in the Parts catalog chapter. See [“Miscellaneous” on page 521.](#)

March 30, 2022

- Removed the following parts in the Power cords assembly in the Parts catalog chapter:
 - PN 40X0289 (Power cord, 2.5 m (straight)—USA)See [“Power cords” on page 519.](#)

March 3, 2022

- Updated the part number of the following parts in the Electronics 2 assembly in the Parts catalog chapter:
 - PN 40X8800 to PN 41X4453 (Paper present flag parts kit)
 - PN 40X8046 to PN 41X4456 (Toner density sensor kit)See [“Electronics 2” on page 495.](#)

- Updated the description of the following parts in the Electronics 2 assembly in the Parts catalog chapter:
 - PN 41X4453 (Paper present flag parts kit)
 - PN 41X4456 (Toner density sensor kit)

See [“Electronics 2” on page 495](#).

- Removed the following parts in the Electronics 2 assembly in the Parts catalog chapter:
 - PN 41X1025 (Toner density wiper kit)

See [“Electronics 2” on page 495](#).

October 1, 2021

- Updated the Media sensor flag removal topic in the Parts removal chapter. See [“Sensor \(toner density\) and media present sensor flag removal” on page 374](#).
- Added Applicability of Regulation (EU) 2019/2015 and (EU) 2019/2020 notice in the Printer specifications chapter.

June 14, 2021

- Updated the Hard disk failure service check topic in the Diagnostics and troubleshooting chapter. See [“Hard disk failure service check” on page 169](#).
- Added the 900 error service check topic in the Diagnostics and troubleshooting chapter. See [“900 error service check” on page 185](#).
- Replaced the System software error service check with the 900 error service check topic in the Diagnostics and troubleshooting chapter.

February 22, 2021

- Updated the Blank pages check topic in the Diagnostics and troubleshooting chapter. For more information, see [“Blank pages check” on page 52](#)

July 13, 2020

- A note for obsolescence was added to the following parts in the Parts catalog chapter:
 - Forms and Bar code card (41X0866)
 - Prescribe card (41X0868)

June 1, 2020

- A note for obsolescence was added to the following parts in the Parts catalog chapter:
 - Adapter, fiber ISP (40x8525)
 - IPDS card (40X8657)

July 12, 2018

- For Performing the initial troubleshooting check, relative humidity values were updated (now 8 to 80%).
- A note for ambient temperature and relative humidity information was added to the Fuser service check.

May 16, 2018

- Updated step 7 of the reverse solenoid removal in the parts removal chapter to disconnect the J10 cable instead of the JDSOL1 cable.

May 3, 2018

- Updated the 24x error code tables in the Diagnostics and troubleshooting chapter.
- Added the 24x.06 service check topic in the Diagnostics and troubleshooting chapter.

April 4, 2018

- Added error code 845.02 and the topic Flatbed scanner CCD initialization error service check under the ADF/Scanner hardware errors in the Diagnostics and troubleshooting chapter.

March 9, 2018

- Updated the ADF service check and the Main drive gearbox service check under the Diagnostics and troubleshooting chapter.

December 19, 2017

- Updated the graphic for PN 40X9131 to include the MPF links in the assembly.
- Added PN 41X2300 for the access cover link under the Covers assembly in the Parts Catalog chapter.
- Added PN 41X1946 under Miscellaneous in the Parts Catalog.

August 23, 2017

- Updated [“Blank pages check” on page 52](#).
- Updated [“Solid black pages check” on page 65](#).

May 31, 2017

- Updated 40X4827 to 40X9652 in the topic “Miscellaneous” in the “Parts catalog” chapter.

May 24, 2017

- Updated the "912 error messages" topic of the "912 errors" subgroup of the "Printer hardware errors" group of the "Diagnostics and troubleshooting" chapter.

May 16, 2017

- Updated the entire group, [“Fixing print quality issues” on page 48](#), which includes replacement of the existing print quality icons with actual print defect outputs. Contents from the Service Manuals, KB and UG articles are merged to come up with the new PQ checks.

April 24, 2017

- Added "MX617de" in the cover.
- Added "MX617de" in the introduction to the “General information” chapter.
- Added 41X2018 to the revised topic "Control panel" in the "Parts catalog" chapter.

December 9, 2016

- Revised a graphic in the “Printhead assembly adjustments” topic in the “Repair information” chapter.
- Revised the “Laser scanning unit (LSU) removal” topic in the “Repair information” chapter.
- Added 41X1025 to the “Electronics 2” topic in the “Parts catalog” chapter.

October 21, 2016

- Updated the topics “Unresponsive imaging unit service check” and “Blank pages check” in the “Diagnostic information” chapter.

September 30, 2016

- Deleted the first step of the “Blank pages check” topic in the “Fixing print quality issues” group in the “Diagnostic information” chapter.

September 14, 2016

- Updated the topic “Redrive assembly removal” in the group “Rear side removals” in the chapter “Diagnostic information.”
- Changed 40X9108 to 41X0917 in the topic “Imaging” in the chapter “Parts catalog.”

September 2, 2016

- Updated the topic “ADF paper jam service check” in the group “Paper jams” in the chapter “Diagnostic information.”

August 17, 2016

- Updated [“ADF paper jam service check” on page 125](#).
- Updated the wiring diagram.
- Moved topics on clearing jams under the topic “Understanding jam messages and locations” in the “Diagnostic information” chapter.
- Updated the topic “Unresponsive imaging unit service check” in the “Diagnostic information” chapter.
- Updated the topic “Miscellaneous” in the “Parts catalog” chapter.
 - Changed 40X8656 to 41X0866.
 - Changed 40X8658 to 41X0868.

July 14, 2016

- Added the separator roll assembly in the “Covers” topic in the “Parts catalog” chapter.

June 28, 2016

- Updated the “LES Applications” topic in the “Service menus” chapter.

June 2, 2016

- Updated the graphic of the “Electronics 2” topic in the “Parts catalog” chapter.
- Updated the “Miscellaneous” topic in the “Parts catalog” chapter.
 - Updated the descriptions for 40X8524, 40X8523, and 40X8526.
 - Added 41X0568.

April 27, 2016

- Updated the Electronics 1 assembly to remove the current callout #3, but added the bin full sensor assembly (sensor, cable, lens).
- Changed the PN for bin full sensor from 40X9092 to 40X9646.
- Updated the covers catalog to remove and transfer the bin full assembly to the electronics 1 catalog.

April 12, 2016

- Updated the Electronics 1 assembly to add bin full sensor with PN 40X9119.

March 23, 2016

- Revised the topic “Fuser removal” in the “Rear side removals” group of the “Repair information” chapter.
- Revised the topic “Right cover removal” in the “Right side removals” group of the “Repair information” chapter.
- Revised the topic “Covers” in the “Parts catalog” chapter.
- Revised the following topics in the “Diagnostic information” chapter:
 - Performing the initial troubleshooting check
 - Initial print quality check
 - User attendance messages (0-99.99)
 - Toner cartridge smart chip contact service check
 - Imaging unit smart chip contact service check
 - Toner smart chip compatibility service check
 - Imaging chip compatibility service check
 - Printer/cartridge mismatch service check
 - Toner starvation service check
- Created these new checks:
 - Unsupported imaging unit service check
 - Unresponsive toner cartridge service check
 - Printer cartridge mismatch
 - Unsupported toner cartridge
 - Supplies mismatch service check
- Updated CTLS service check. Even changed the title to “Unresponsive imaging unit service check.”

February 18, 2016

- Added the topic “Enabling the security reset jumper” in “Appendix A: Printer specifications” chapter.

January 10, 2016

- Removed 41X0003 from the topic “Electronics 2” in the “Parts catalog” chapter.

December 15, 2015

- Updated the topic “Fuser removal” of the “Rear side” group of the “Repair information” chapter to add installation notes.

December 1, 2015

- Updated the topic “Toner density sensor removal” in the “Bottom removals” group in the “Repair information” chapter to add installation notes.
- Updated the topic “Frame” in the “Parts catalog” chapter to update 40X8278 to 40X8777.

November 17, 2015

- Change PN 40X8047 to 40X8045.

November 4, 2015

- Added the “201 paper jams” subgroup in the “Paper jams” group in the “Diagnostic information” chapter.
- Added step 6, with graphic, in the “MPF tray removal” topic in the “Front removals” group in the “Repair information” chapter.
- Revised graphics and table entries in the “Electronics 1” and “Electronics 2” topics in the “Parts catalog” chapter.
- Revised graphics in the “Option trays” topic in the “Parts catalog” chapter.

October 13, 2015

- Cross-references pointing to scanner manual registration and scanner calibration were added to the scanner assembly and flatbed assembly removals.

June 10, 2015

- The control panel assembly (41X0756) FRU was added to the Control panel parts catalog.
- FRUs were deleted on the Control panel parts catalog.
 - 40X9089 (LCD top cover)
 - 40X7861 (7" LCD (touch-screen))
 - 40X9120 (Keypad assembly cover)
 - 40X9130 (UICC)
 - 40X9085 (UICC video cable)
 - 40X9115 (Interface card)

May 13, 2015

- Updated [“200 paper jam messages” on page 95](#) to add error codes specific to polygon laser scanning unit (LSU).
- Updated [“111 error messages” on page 170](#) to add error messages specific to polygon LSU. Added notes to identify the type of LSU (polygon or galvo) and controller board the printer supports.
- Updated [“Laser scanning unit \(LSU\) service check” on page 173](#) to include other ways to resolve LSU-related issues. Added notes to identify the type of LSU (polygon or galvo) and controller board the printer supports.
- Updated [“Laser scanning unit \(LSU\) removal” on page 395](#) to add information on how to identify the type of LSU (polygon or galvo) and controller board the printer supports.
- Updated [“Electronics 1” on page 491](#) to specify whether the LSU that the printer supports is a polygon or galvo. Added in the table these two FRUs: Polygon LSU frame (PN 41X0363) and Polygon LSU cable (41X0759).

April 23, 2015

- Updated the 97y error code table and created [“Network port error service check” on page 194](#) for the 97y error codes.
- Updated the 98y error code table and created [“Option communication error service check” on page 195](#) for the 98y error codes.
- Updated the 99y error code table and created [“Option communication error service check” on page 195](#) for the 99y error codes.

April 6, 2015

- 40X8086 FRU was renamed to '550-sheet tray insert'
- 40X8261 FRU was renamed to 'ACM assembly (standard tray only)'
- 40X8262 FRU was renamed to 'ACM assembly (option tray only)'

February 5, 2015

- Part number 41X0259 (Narrow media sensor) was added to the parts catalog.

October 10, 2014

- Updated the illustration of Electronics 2 parts catalog assembly to show the correct toner cartridge smart chip contact.

September 22, 2014

- Part number 40X8274 was replaced with 40X9181.

August 15, 2014

Updated the following service checks:

- Toner cartridge smart chip contact service check
- Cartridge gearbox service check
- Toner starvation service check
- LSU service check
- Tray 1 jam service check

August 7, 2014

- Scanner carriage failure service check was added to address the 843.00 error.

July 2, 2014

- Art revised for Frame parts catalog: spring (40X8295) and cable (40X8083) are no longer included.

June 23, 2014

- Parts catalog—Art was revised for Assembly 1: Covers.

June 11, 2014

- Parts catalog—Added Latin America power supply part number 41X0003.

May 23, 2014

- Added part number 40X0289 to the power cords parts catalog assembly.

April 1, 2014

- Note for updating the scanner firmware was added to the ADF paper jam service check.

March 3, 2014

- Added the Restoring solutions, licenses, and configuration settings topic under Removal precautions.
- Updated the Restoring the printer configuration after replacing the controller board topic.

- Changed the title from eSF backup to Backing up eSF solutions and settings, and updated the topic.
- Updated the Controller board removal topic.
- Editorial changes

January 17, 2014

- Restore factory defaults topics were added to the service menus.
- Updating the printer firmware topics were added to the repair information.

November 26, 2013

- Part number 40X8850 (Redrive shaft) was added to the parts catalog.
- Redrive shaft removal was added to the repair information.

October 22, 2013

- Part number 40X8331 (MarkNet N8350 802.11 b/g/n Wireless Print Server (MX31x, MX41x)) was deleted.
- Part number 40X9654 (550--sheet tray, lockable) was added.

October 2, 2013

- Part number 40X8857 (Controller board) was changed to 40X9254.

August 20, 2013

- Fax card (40X7854) was included in the parts catalog.

August 13, 2013

- Topic for restoring the printer configuration after replacing the controller board was added.
- Additional procedure added for the installation note for the controller board removal topic.
- Parts catalog FRU (40X9099—Top cover) was included.

July 11, 2013

- Parts catalog FRU (40X8700—Relocation kit) was added.

June 25, 2013

- Parts catalog FRU number (40X9134—Controller board) was changed to 40X8857.

June 19, 2013

- Changes were made to the ADF paper jam service check.
- Installation warning was added to the Bin full sensor removal.
- Part number 40X8093 (Transfer roll) was changed to 40X8393.
- BSD model information was added to the FRU tables on the parts catalog.
- Some information from the error code tables were made into new service checks. The following are the new service check topics added:
 - ADF rattling noise service check
 - Imaging unit low service check
 - Toner cartridge low service check
 - Bin full service check

- Toner smart chip compatibility service check
- Imaging chip compatibility service check
- Flash full service check
- Maintenance kit service check
- NVRAM cyclic redundancy service check
- Invalid firmware/controller board service check
- RAM memory error service check
- Scanner configuration error service check
- Blank spaces on incoming fax service check
- Stretched words on incoming fax service check
- Download emulation cyclic redundancy service check

March 27, 2013

- Updated the ACM assembly removal procedure.
- Added Media sensor flag removal procedure.
- Updated the Sensor (input) early/late arriving service check to include checking of the media present sensor flag.
- Added media present sensor flag part number 40X8800 to the Electronics 2 parts catalog assembly.
- Revised the following staple finisher-related topics:
 - 45y.xx paper jams
 - Ejector jam service check
 - Finisher jam service check
 - Stapler carriage jam service check
 - Stapler priming jam service check
- New staple finisher-related topics added:
 - Diagnostic information
 - Stapler left tamper jam service check
 - Stapler right tamper jam service check
 - Service menus
 - Staple Test
 - Feed Test
 - Sensor Test
 - Repair information
 - Tamper main assembly removal
 - Tamper sub-assembly removal
 - Diverter gearbox removal
 - Stapler accumulator assembly removal
 - Sensor (stapler right tamper HP) removal
 - Sensor (stapler left tamper HP) removal
 - Sensor (stapler paddle HP) removal

Parts catalog

- Staple finisher exit assembly
- Staple finisher tamper assembly
- Staple finisher accumulator assembly

February 19, 2013

- A FRU (40X8540) was added to the parts catalog.

February 4, 2013

- New topic for updating the firmware was added to the Service menus chapter.
- BSD machines were added to the list of models under the General information chapter.

General information

Printer model configurations

The Lexmark™ MX610 and MX611 (7016-6xx) are network-capable, multifunction laser printers that print monochrome print jobs. All information in this service manual pertains to all models unless explicitly noted.

The printers are available in the following models:

Model	Configurations	Machine type / model
MX610de	Mono laser MFP, Networking, Duplex print, e-task 7-inch color touch screen	7016-630
MX611de	Mono laser MFP, Networking/Fax, Duplex print/scan, e-Task 7-inch color touch screen	7016-670
MX617de		7016-670
XM3150		7016-679
MX611dhe	Mono laser MFP, Networking/Fax, Duplex print/scan, e-Task 7-inch color touch screen, Hard disk	7016-675

The diagnostic information in this manual leads you to the correct field replaceable unit (FRU) or part. Use the error code charts, symptom index, and service checks to determine the symptom and then repair the failure. After you complete the repair, perform tests as needed to verify the repair.

To begin diagnosing a problem, go to [“Diagnostics and troubleshooting” on page 45](#). For information about removing and reinstalling parts, see [“Parts removal” on page 277](#). See [“Parts catalog” on page 484](#) to help identify parts.

Media guidelines

Additional information for printing on specialty media may be found in the *Cardstock and Label Guide* available at <http://support.lexmark.com>.

Paper guidelines

Selecting the correct paper or specialty media reduces printing problems. For the best print quality, try a sample of the paper or specialty media before buying large quantities.

Paper characteristics

The following paper characteristics affect print quality and reliability. Consider these characteristics when evaluating new paper stock.

Weight

The standard printer trays can automatically feed paper weights up to 90-g/m² (24-lb) bond grain long paper. The optional trays can automatically feed paper weights up to 120-g/m² (32-lb) bond grain long paper. The multipurpose feeder can automatically feed paper weights up to 163-g/m² (43-lb) bond grain long paper. Paper lighter than 60 g/m² (16 lb) might not be stiff enough to feed properly, causing jams. For best performance, use 75-g/m² (20-lb) bond grain long paper. For paper smaller than 182 x 257 mm (7.2 x 10.1 inches), it is recommended to use 90 g/m² (24 lb) or heavier paper.

Note: Two-sided printing is supported only for 60–90-g/m² (16–24-lb) bond paper.

Curl

Curl is the tendency for paper to curl at its edges. Excessive curl can cause paper feeding problems. Curl can occur after the paper passes through the printer, where it is exposed to high temperatures. Storing paper unwrapped in hot, humid, cold, or dry conditions, even in the trays, can contribute to paper curling prior to printing and can cause feeding problems.

Smoothness

Paper smoothness directly affects print quality. If paper is too rough, toner cannot fuse to it properly. If paper is too smooth, it can cause paper feeding or print quality issues. Always use paper between 100 and 300 Sheffield points; smoothness between 150–250 Sheffield points produces the best print quality.

Moisture content

The amount of moisture in paper affects both print quality and the ability of the printer to feed the paper correctly. Leave paper in its original wrapper until it is time to use it. This limits the exposure of paper to moisture changes that can degrade its performance.

Condition paper before printing by storing it in its original wrapper in the same environment as the printer for 24–48 hours before printing. Extend the time to several days if the storage or transportation environment is very different from the printer environment. Thick paper may also require a longer conditioning period.

Grain direction

Grain refers to the alignment of the paper fibers in a sheet of paper. Grain is either *grain long*, running the length of the paper, or *grain short*, running the width of the paper.

For 60–90-g/m² (16–24-lb) bond paper, grain long paper is recommended.

Fiber content

Most high-quality xerographic paper is made from 100% chemically treated pulped wood. This content provides the paper with a high degree of stability resulting in fewer paper feeding problems and better print quality. Paper containing fibers such as cotton can negatively affect paper handling.

Unacceptable paper

The following paper types are not recommended for use with the printer:

- Chemically-treated papers used to make copies without carbon paper, also known as carbonless papers, carbonless copy paper (CCP), or no carbon required (NCR) paper
- Preprinted papers with chemicals that may contaminate the printer
- Preprinted papers that can be affected by the temperature in the printer fuser

- Preprinted papers that require a registration (the precise print location on the page) greater than ± 2.4 mm (± 0.9 inch), such as optical character recognition (OCR) forms

In some cases, registration can be adjusted with a software application to successfully print on these forms:

- Coated papers (erasable bond), synthetic papers, thermal papers
- Rough-edged, rough or heavily textured surface papers, or curled papers
- Recycled papers that fail EN12281:2002 (European)
- Paper weighing less than 60 g/m^2 (16 lb)
- Multiple-part forms or documents

Selecting paper

Using the appropriate paper prevents jams and helps ensure trouble-free printing.

To help avoid paper jams and poor print quality:

- *Always* use new, undamaged paper.
- Before loading paper, know the recommended printable side of the paper. This information is usually indicated on the paper package.
- *Do not* use paper that has been cut or trimmed by hand.
- *Do not* mix paper sizes, types, or weights in the same tray; mixing results in jams.
- *Do not* use coated papers unless they are specifically designed for electrophotographic printing.

Selecting preprinted forms and letterhead

Use these guidelines when selecting preprinted forms and letterhead:

- Use grain long for 60 to 90 g/m^2 (16 to 24 lb) weight paper.
- Use only forms and letterhead printed using an offset lithographic or engraved printing process.
- Avoid papers with rough or heavily textured surfaces.

Use papers printed with heat-resistant inks designed for use in xerographic copiers. The ink must be able to withstand temperatures up to 190°C (374°F) without melting or releasing hazardous emissions. Use inks that are not affected by the resin in toner. Inks that are oxidation-set or oil-based generally meet these requirements; latex inks might not. When in doubt, contact the paper supplier.

Preprinted papers such as letterhead must be able to withstand temperatures up to 190°C (374°F) without melting or releasing hazardous emissions.

Storing paper

Use these paper storage guidelines to help avoid jams and uneven print quality:

- For best results, store paper where the temperature is 21°C (70°F) and the relative humidity is 40 percent. Most label manufacturers recommend printing in a temperature range of 18 – 24°C (65 – 75°F) with relative humidity between 40 and 60 percent.
- Store paper in cartons, on a pallet or shelf, rather than on the floor.
- Store individual packages on a flat surface.
- Do not store anything on top of individual paper packages.
- Take paper out of the carton or wrapper only when you are ready to load it in the printer. The carton and wrapper help keep the paper clean, dry, and flat.

Using recycled paper and other office papers

As an environmentally conscious company, Lexmark supports the use of recycled office paper produced specifically for use in laser (electrophotographic) printers. In 1998, Lexmark presented to the US government a study demonstrating that recycled paper produced by major mills in the US fed as well as non-recycled paper. However, no blanket statement can be made that *all* recycled paper will feed well.

Lexmark consistently tests its printers with recycled paper (20–100% post-consumer waste) and a variety of test paper from around the world, using chamber tests for different temperature and humidity conditions. Lexmark has found no reason to discourage the use of today's recycled office papers, but generally the following property guidelines apply to recycled paper.

- Low moisture content (4–5%)
- Suitable smoothness (100–200 Sheffield units, or 140–350 Bendtsen units, European)

Note: Some much smoother papers (such as premium 24 lb laser papers, 50–90 Sheffield units) and much rougher papers (such as premium cotton papers, 200–300 Sheffield units) have been engineered to work very well in laser printers, despite surface texture. Before using these types of paper, consult your paper supplier.

- Suitable sheet-to-sheet coefficient of friction (0.4–0.6)
- Sufficient bending resistance in the direction of feed

Recycled paper, paper of lower weight (<60 g/m² [16 lb bond]) and/or lower caliper (<3.8 mils [0.1 mm]), and paper that is cut grain-short for portrait (or short-edge) fed printers may have lower bending resistance than is required for reliable paper feeding. Before using these types of paper for laser (electrophotographic) printing, consult your paper supplier. Remember that these are general guidelines only and that paper meeting these guidelines may still cause paper feeding problems in any laser printer (for example, if the paper curls excessively under normal printing conditions).

Using specialty media

Tips on using card stock

Card stock is heavy, single-ply specialty media. Many of its variable characteristics, such as moisture content, thickness, and texture, can significantly impact print quality. Print samples on the card stock being considered for use before buying large quantities.

- From the Paper menu, set the Paper Type to Card Stock.
- Select the appropriate Paper Texture setting.
- Be aware that preprinting, perforation, and creasing may significantly affect the print quality and cause jams or other paper handling problems.
- Check with the manufacturer or vendor to ensure the card stock can withstand temperatures up to 220°C (446°F) without releasing hazardous emissions.
- Do not use preprinted card stock manufactured with chemicals that may contaminate the printer. Preprinting introduces semi-liquid and volatile components into the printer.
- Use grain short card stock when possible.

Tips on using envelopes

Print samples on the envelopes being considered for use before buying large quantities.

- Use envelopes designed specifically for laser/LED printers. Check with the manufacturer or vendor to ensure that the envelopes can withstand temperatures up to 220°C (446°F) without sealing, wrinkling, curling excessively, or releasing hazardous emissions.
- For best performance, use envelopes made from 90 g/m² (24 lb bond) paper or 25% cotton. All-cotton envelopes must not exceed 70 g/m² (20 lb bond) weight.
- Use only new envelopes from undamaged packages.
- To optimize performance and minimize jams, do not use envelopes that:
 - Have excessive curl or twist
 - Are stuck together or damaged in any way
 - Have windows, holes, perforations, cutouts, or embossing
 - Have metal clasps, string ties, or folding bars
 - Have an interlocking design
 - Have postage stamps attached
 - Have any exposed adhesive when the flap is in the sealed or closed position
 - Have bent corners
 - Have rough, cockle, or laid finishes
- Adjust the width guides to fit the width of the envelopes.

Note: A combination of high humidity (over 60%) and the high printing temperature may wrinkle or seal envelopes.

Tips on using labels

Print samples on the labels being considered for use before buying large quantities.

Note: Use only paper label sheets. Vinyl, pharmacy, and two-sided labels are not supported.

For more information on label printing, characteristics, and design, see the *Card Stock & Label Guide* available at <http://support.lexmark.com>.

When printing on labels:

- Use labels designed specifically for laser printers. Check with the manufacturer or vendor to verify that:
 - The labels can withstand temperatures up to 230°C (446°F) without sealing, excessive curling, wrinkling, or releasing hazardous emissions.
 - Label adhesives, face sheet (printable stock), and topcoats can withstand up to 25-psi (172-kPa) pressure without delaminating, oozing around the edges, or releasing hazardous fumes.
- Do not use labels with slick backing material.
- Use full label sheets. Partial sheets may cause labels to peel off during printing, resulting in a jam. Partial sheets also contaminate the printer and the cartridge with adhesive, and could void the printer and toner cartridge warranties.
- Do not use labels with exposed adhesive.
- Do not print within 1 mm (0.04 inches) of the edge of the label, of the perforations, or between die-cuts of the label.

- Make sure the adhesive backing does not reach to the edge of the sheet. Zone coating of the adhesive should be at least 1 mm (0.04 inches) away from edges. Adhesive material contaminates the printer and could void the warranty.
- If zone coating of the adhesive is not possible, then remove a 2-mm (0.06-inches) strip on the leading and driver edge, and use a non-oozing adhesive.
- Portrait orientation is recommended, especially when printing bar codes.

Tips on using letterhead

- Use letterhead designed specifically for laser printers.
- Print samples on the letterhead being considered for use before buying large quantities.
- Before loading letterhead, flex, fan, and straighten the stack to prevent sheets from sticking together.
- Page orientation is important when printing on letterhead.

Tips on using transparencies

- Print a test page on the transparencies being considered for use before buying large quantities.
- Feed transparencies from the standard tray, or the multipurpose feeder.
- Use transparencies designed specifically for laser printers. Transparencies must be able to withstand temperatures up to 185°C (365°F) without melting, discoloring, offsetting, or releasing hazardous emissions.

Note: If the transparency weight is set to Heavy and the transparency texture is set to Rough in the Paper menu, then transparencies can be printed at a temperature up to 195°C (383°F).

- Avoid getting fingerprints on the transparencies to prevent print quality problems.
- Before loading transparencies, flex, fan, and straighten the stack to prevent sheets from sticking together.

Supported paper sizes, types, and weights

Supported paper sizes

Paper size and dimension	Standard 550-sheet tray	Optional 250- or 550-sheet tray	Multipurpose feeder	ADF	Scanner glass	Duplex mode
Business card	X	X	X	X	✓	X
3 x 5 in.	X	X	✓	X	✓	X
4 x 6 in.	X	X	✓	X	✓	X
A4 210 x 297 mm (8.27 x 11.7 in.)	✓	✓	✓	✓	✓	✓
A5 148 x 210 mm (5.83 x 8.27 in.)	✓	✓	✓	✓	✓	X
* Universal is supported in duplex mode only if the width is at least 210 mm (8.27 in.) and the length is at least 279.4 mm (11 in.). The smallest supported Universal size is supported only in the multipurpose feeder.						

Paper size and dimension	Standard 550-sheet tray	Optional 250- or 550-sheet tray	Multipurpose feeder	ADF	Scanner glass	Duplex mode
A6 105 x 148 mm (4.13 x 5.83 in.)	✓	✗	✓	✓	✓	✗
JIS B5 182 x 257 mm (7.17 x 10.1 in.)	✓	✓	✓	✓	✓	✗
Letter 215.9 x 279.4 mm (8.5 x 11 in.)	✓	✓	✓	✓	✓	✓
Legal 215.9 x 355.6 mm (8.5 x 14 in.)	✓	✓	✓	✓	✓	✓
Executive 184.2 x 266.7 mm (7.25 x 10.5 in.)	✓	✓	✓	✓	✓	✗
Oficio (México) 215.9 x 340.4 mm (8.5 x 13.4 in.)	✓	✓	✓	✓	✓	✓
Folio 215.9 x 330.2 mm (8.5 x 13 in.)	✓	✓	✓	✓	✓	✓
Statement 139.7 x 215.9 mm (5.5 x 8.5 in.)	✓	✓	✓	✓	✓	✗
Universal* 76.2 x 127 mm (3 x 5 in.) to 215.9 x 359.92 mm (8.5 x 14.17 in.)	✓	✓	✓	✓	✓	✓
7 3/4 Envelope (Monarch) 98.4 x 190.5 mm (3.875 x 7.5 in.)	✗	✗	✓	✗	✗	✗
9 Envelope 98.4 x 226.1 mm (3.875 x 8.9 in.)	✗	✗	✓	✗	✗	✗
10 Envelope 104.8 x 241.3 mm (4.12 x 9.5 in.)	✗	✗	✓	✗	✗	✗

* Universal is supported in duplex mode only if the width is at least 210 mm (8.27 in.) and the length is at least 279.4 mm (11 in.). The smallest supported Universal size is supported only in the multipurpose feeder.

Paper size and dimension	Standard 550-sheet tray	Optional 250- or 550-sheet tray	Multipurpose feeder	ADF	Scanner glass	Duplex mode
DL Envelope 110 x 220 mm (4.33 x 8.66 in.)	X	X	✓	X	X	X
C5 Envelope 162 x 229 mm (6.38 x 9.01 in.)	X	X	✓	X	X	X
B5 Envelope 176 x 250 mm (6.93 x 9.84 in.)	X	X	✓	X	X	X
Other Envelope 85.7 x 165 mm to 215.9 x 355.6 mm (3.375 x 6.50 in. to 8.5 x 14 in.)	X	X	✓	X	X	X

* Universal is supported in duplex mode only if the width is at least 210 mm (8.27 in.) and the length is at least 279.4 mm (11 in.). The smallest supported Universal size is supported only in the multipurpose feeder.

Supported paper types and weights

Note: Labels, transparencies, envelopes, and card stock always print at a reduced speed.

Paper type	Standard 550-sheet tray	250- or 550-sheet tray	Multipurpose feeder	Duplex mode	ADF	Scanner glass
Plain paper	✓	✓	✓	✓	✓	✓
Card stock	X	X	✓	X	✓	✓
Transparencies	X	✓ ¹	✓	X	✓	✓
Recycled	✓	✓	✓	✓	✓	✓
Paper labels	✓	✓	✓	X	✓	✓
Bond	X	X	✓	X	✓	✓
Envelope²	✓	✓	✓	✓	✓	✓
Rough envelope	X	X	✓	X	✓	✓
Letterhead	✓	✓	✓	✓	✓	✓
Preprinted	✓	✓	✓	✓	✓	✓
Colored paper	✓	✓	✓	✓	✓	✓

¹ Transparencies are supported only in the 250-sheet tray.
² Use envelopes that lie flat when individually placed on a table facedown.

Paper type	Standard 550-sheet tray	250- or 550-sheet tray	Multipurpose feeder	Duplex mode	ADF	Scanner glass
Light paper	✓	✓	✓	✓	✓	✓
Heavy paper	✓	✓	✓	✓	✓	✓
Rough/Cotton	✓	✓	✓	X	✓	✓
Custom Type [x]	✓	✓	✓	✓	✓	✓

¹ Transparencies are supported only in the 250-sheet tray.

² Use envelopes that lie flat when individually placed on a table facedown.

Data security notice

- 1 The printer contains various types of memory that store printer and network settings, information from embedded solutions, and user data.

The following are the types of memory and data that they store.

- **Volatile memory**—The printer uses standard random access memory (RAM) to buffer user data temporarily during simple print and copy jobs.
- **Non-volatile memory**—The printer may use two forms of non-volatile memory: EEPROM and NAND (flash memory). Both types are used to store the operating system, printer settings, network information, scanner and bookmark settings, and embedded solutions.
- **Hard disk memory**—The printer hard disk is designed for printer-specific functionality and cannot be used for the long-term storage of data that is not print-related. The hard disk can retain buffered user data from complex print jobs, form data, and font data.

To erase volatile memory, turn off the printer.

To erase the non-volatile and printer hard disk memory, see [“Configuration menu” on page 261](#).

The following parts are capable of storing memory:

- Printer control panel
- User interface controller card (UICC)
- Controller board
- Optional hard disk

Note: The control panel and controller board contain NVRAM.

- 2 After removing the old part, return it to your next level of support.

Tools required for service

- Flat-blade screwdrivers, various sizes
- #1 Phillips screwdriver, magnetic
- #2 Phillips screwdriver, magnetic

- #2 Phillips screwdriver, magnetic short-blade
- Needle-nose pliers
- Diagonal side cutters
- Spring hook
- Feeler gauges
- Analog or digital multimeter
- Flashlight (optional)

Diagnostics and troubleshooting

- “Troubleshooting overview” on page 45
- “Securing the printer” on page 47
- “Fixing print quality issues” on page 48
- “Paper jams” on page 89
- “Understanding the printer messages” on page 145
- “User attendance messages” on page 160
- “Printer hardware errors” on page 170
- “ADF/Scanner hardware errors” on page 197
- “Input/output option hardware errors” on page 219
- “Other symptoms” on page 224

 **CAUTION—SHOCK HAZARD:** Remove the power cord from the electrical outlet before you connect or disconnect any cable or electronic card or assembly for personal safety and to prevent damage to the printer. Disconnect any connections between the printer and PCs/peripherals.

 **CAUTION—POTENTIAL INJURY:** The printer weight is greater than 18 kg (40 lb) and requires two or more trained personnel to lift it safely. Use the hand holds on the side of the printer. Make sure your fingers are not under the printer when you lift or set the printer on the floor or another stable surface.

 **CAUTION—HOT SURFACE:** The inside of the printer might be hot. To reduce the risk of injury from a hot component, allow the surface to cool before touching it.

Troubleshooting overview

- “Performing the initial troubleshooting check” on page 45
- “Power-on Reset (POR) sequence” on page 46
- “Using Safe Mode” on page 46

Performing the initial troubleshooting check

Before you start the troubleshooting procedures, perform the following checks:

- Use genuine Lexmark supplies and parts for the best results. Third-party supplies or parts may affect the performance, reliability, or life of the printer and its imaging components.
- With the power cord unplugged from the electrical outlet, check that the cord is free from the breakage, short circuits, disconnected wires, or incorrect connections.
- Make sure the printer is properly grounded. Check the power cord ground terminal.
- Make sure the power supply line voltage is within 10% of the rated line voltage.
- Make sure the machine is securely installed on a level surface in a well-ventilated area.
- Make sure the room temperature is between 16 and 32°C (60 and 90°F) and that the relative humidity is between 8 and 80%.

- Avoid sites generating ammonia gas, high temperature, high humidity (near water faucets, kettles, humidifiers), cold spaces, near open flames, and dusty areas.
- Avoid sites exposed to direct sunlight.
- Make sure the paper is the recommended paper for this printer.
- Make a trial print with paper from a newly opened package, and check the result.

Power-on Reset (POR) sequence

When you turn on the printer, it performs a POR sequence.

Check for correct POR functioning of the base printer by observing the following:

- 1 The control panel indicator light turns on.
- 2 The control panel display turns on.
- 3 A splash screen appears on the display.
- 4 The cooling fan turns on.
- 5 The fuser heater turns on.
Note: The fuser takes longer to warm up from a cold start than from a warm start.
- 6 The main drive motor turns on.
- 7 The EP drive assembly drives the developer shaft located in the imaging unit.
- 8 The exit rollers turn.
- 9 The control panel indicator light blinks.
- 10 **Ready** appears on the display.

Using Safe Mode

Safe Mode lets the printer continue to operate in a special limited mode in which it attempts to continue offering as much functionality as possible despite known issues.

Warning—Potential Damage: Safe Mode is intended as a short-term workaround and should be used only in the case of a non-critical error when a print job must be completed before service can be arranged to repair the printer. The printer must be returned to standard operating mode before diagnostics can be run or full-function printing can continue.

You can enter Safe Mode in one of the following ways:

- Enable Safe Mode from the Configuration menu, and then POR the printer.
- Press the **Stop** and **Back** keys, and then POR the printer.

Return the printer to standard operating mode to service the printer and return to full-function printing.

Safe mode print behavior

The following table outlines the behavior for this printer model while in Safe Mode:

Safe Mode engine features	Engine behavior	Control panel behavior
Simplex printing only	Will report that no duplexer is installed.	Duplex print option will not be selectable.
Ignore duplex sensor		
Ignore bin full sensor	Bin full messages will not be reported.	Bin full messages will not occur.
Print at narrow media operating point	Pages will be printed slower.	N/A
Ignore narrow media sensor	Narrow media will print without restrictions.	N/A
Ignore all input options	Will report that only Tray 1 is installed.	Only Tray 1 and the MPF will be selectable.
Ignore all output options	Will not report any installed finishing options.	Finishing options will not be selectable.
Use large interpage gaps	Pages will have large interpage gaps.	N/A

Securing the printer

Resetting the printer without admin credentials

Notes:

- Resetting the printer or replacing the controller board deletes all security settings.
- Before changing the security settings, ask permission from your administrator.

1 Perform an Out of Service Erase to reset the printer to factory defaults without using admin credentials. For more information, see [“Data security notice” on page 277](#).

Warning—Potential Damage: This method makes the device vulnerable to hacking because it allows the creation of an admin account afterwards. By default, newer firmware versions restrict Out of Service Erase to admin users only, making the printer more secure and remembering the admin password more important.

2 If Out of Service Erase is unavailable, then use the security reset jumper to reset the printer to factory defaults. For more information, see [“Using the security reset jumper” on page 47](#).

3 If the effect of the jumper reset is disabled, then replace the controller board. For more information, see [“Controller board removal” on page 320](#).

Using the security reset jumper

The security reset jumper is on the controller board. It can be used if the admin password is lost or forgotten, and Out of Service Erase is not available.

Notes:

- To enable the effect of the security reset jumper, from the Embedded Web Server, navigate to: **Settings > Security > Miscellaneous Security Settings > Security Reset Jumper > Enable “Guest” Access**.

- To disable the effect of the jumper, select **No Effect** from the Security Reset Jumper section in the Security menu. If the password is forgotten or lost, perform an Out of Service Erase or replace the controller board. See [“Resetting the printer without admin credentials” on page 47](#) or [“Controller board removal” on page 320](#).
- 1 Turn off the printer.
 - 2 Remove the controller board shield.
 - 3 Locate the security jumper on the controller board.

Note: The small, yellow jumper is located beside a lock icon on the controller board.
 - 4 Move the jumper to cover the middle and exposed prongs.

Note: The movement of the jumper triggers the reset, not the jumper position.
 - 5 Attach the controller board shield.
 - 6 Turn on the printer.

Notes:

- The security framework remains in place after the reset. Public permissions are reset to default and now include Out of Service Erase as an option.
- If LDAP is used to authenticate the copy function in MFPs, then the LDAP configuration and copy function are no longer protected.
- If Enable Audit is activated in the Security Audit Log, then the printer logs a message each time the jumper is reset.
- Physical access to the printer is required to use the jumper, making it more secure against hacking. To prevent tampering of the jumper, secure the controller board cage with a Kensington lock.

Fixing print quality issues

- [“Initial print quality check” on page 49](#)
- [“Gray background or toner fog check” on page 50](#)
- [“Blank pages check” on page 52](#)
- [“Print is too dark check” on page 58](#)
- [“Print is too light check” on page 60](#)
- [“Paper curl check” on page 62](#)
- [“Folded or wrinkled paper check” on page 64](#)
- [“Solid black pages check” on page 65](#)
- [“Repeating defects check” on page 68](#)
- [“Skewed print check” on page 69](#)
- [“Streaked vertical lines appear on prints check” on page 71](#)
- [“Horizontal light bands check” on page 72](#)
- [“Vertical light bands check” on page 74](#)
- [“Vertical dark bands check” on page 75](#)
- [“Vertical dark streaks with print missing check” on page 76](#)
- [“White streaks and voided areas check” on page 78](#)

- [“Fine lines are not printed correctly \(specifically Chinese characters\) check” on page 81](#)
- [“Clipped pages or images check” on page 82](#)
- [“Compressed images appear on prints check” on page 84](#)
- [“Incorrect margins on prints check” on page 85](#)
- [“Toner rubs off check” on page 86](#)
- [“Toner specks appear on prints check” on page 87](#)

The symptoms described in this chapter might require replacement of one or more CRUs (Customer Replaceable Units) designated as supplies or maintenance items, which are the responsibility of the customer. With the customer's permission, you might need to install a toner cartridge.

Initial print quality check

Before troubleshooting specific print problems, complete the following initial print quality check:

- Use only genuine Lexmark supplies. Third-party supplies may cause print quality problems.
- The printer must be in a location that follows the recommended operating environment specifications. See [“Operating environment” on page 524](#).
- Check the life status of all supplies. Any supply that is low should be replaced.
- Load 20-lb plain letter or A4 paper. Make sure the paper guides are properly set and locked. From the control panel, set the paper size and type to match the paper loaded in the tray.
- Print a menu settings page. Be sure to keep the original menu settings page to restore the customer's custom settings if needed.
- Verify on the menu settings page if the following are set to their default values:
 - Print resolution: 600 dpi
 - Toner darkness: 8
- Check the transfer roll for damage. Replace if damaged.
- Check the toner cartridge and imaging unit for damage. Replace if damaged.
- Print the print quality pages to see if the problem remains. Use Tray 1 to test print quality problems.
- Print a print quality test page, and then look for variations in the print from what is expected. Verify if the settings under EP Setup are set to their default values. See [“EP Defaults” on page 253](#).
- Check to ensure the correct printer driver for the installed software is being used. An incorrect printer driver for the installed software can cause problems. Incorrect characters could print, and the copy may not fit the page correctly.

Gray background or toner fog check

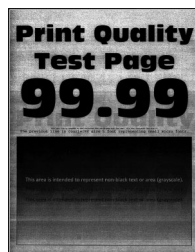

Actions	Yes	No
<p>Step 1</p> <p>a Turn off the printer, wait for 10 seconds, and then turn on the printer.</p> <p>b From the control panel:</p> <ol style="list-style-type: none"> 1 Increase the toner darkness in the Quality menu. Note: 8 is the factory default setting. 2 Set the paper type, texture, and weight in the Paper menu to match the paper loaded. <p>Does the problem remain?</p>	Go to step 2.	The problem is solved.
<p>Step 2</p> <p>Check if the printer is using a genuine and supported Lexmark toner cartridge.</p> <p>Note: If the printer is using a third-party cartridge, then refer the users to their cartridge supplier.</p> <p>Is the printer using a genuine and supported toner cartridge?</p>	Go to step 4.	Go to step 3.
<p>Step 3</p> <p>Install a genuine and supported toner cartridge.</p> <p>Does the problem remain?</p>	Go to step 4.	The problem is solved.

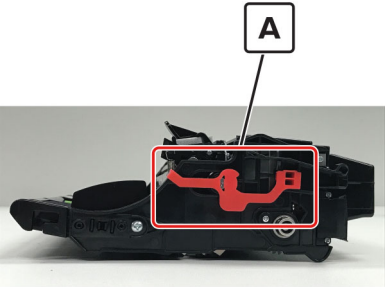
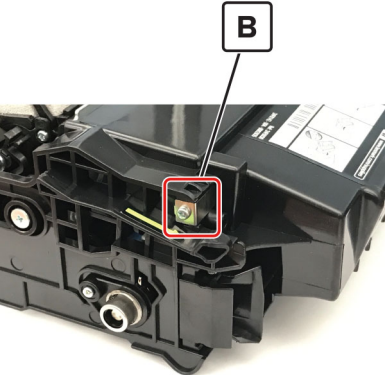
Actions	Yes	No
<p>Step 4</p> <p>a Remove any packing material left on the imaging unit, including the red separator plastic (A).</p>  <p>Note: You may need a pair of pliers to remove a piece of broken plastic inside the imaging unit.</p> <p>b Check the charge roller contact (B) on the right side of the imaging unit for damage and contamination.</p>  <p>Is the charge roller contact damaged and contaminated?</p>	Go to step 5.	Go to step 6.
<p>Step 5</p> <p>Repair or replace the charge roller contact on the imaging unit.</p> <p>Does the problem remain?</p>	Go to step 6.	The problem is solved.
<p>Step 6</p> <p>Replace the imaging unit.</p> <p>Does the problem remain?</p>	Go to step 7.	The problem is solved.
<p>Step 7</p> <p>Make sure that connection JPS1 on the controller board and the connections on the power supply are properly connected.</p> <p>Are the connections properly connected?</p>	Go to step 9.	Go to step 8.

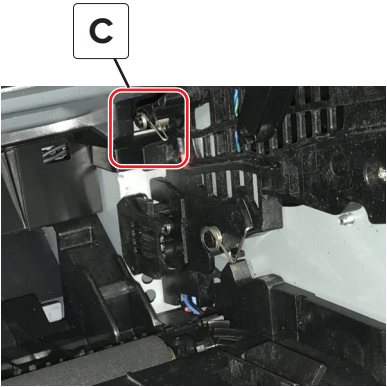
Actions	Yes	No
<p>Step 8 Reseat the connections.</p> <p>Does the problem remain?</p>	Go to step 9.	The problem is solved.
<p>Step 9</p> <p>Note: Poor electrical contact to the photoconductor is the most likely source of a full page background defect.</p> <p>a Remove any contamination from the photoconductor charge contact (C) on the right side of the frame.</p> <div data-bbox="402 569 786 953" style="text-align: center;">  </div> <p>b Perform a print test.</p> <p>Does the problem remain?</p>	Go to step 10.	The problem is solved.
<p>Step 10</p> <p>Check if the photoconductor charge contact is bent, damaged, or not in proper contact with the imaging unit.</p> <p>Is the contact free from damage and in proper contact with the imaging unit?</p>	Go to step 11.	Contact the next level of support.
<p>Step 11</p> <p>Replace the power supply. See “Power supply removal” on page 361.</p> <p>Does the problem remain?</p>	Contact the next level of support.	The problem is solved.

Blank pages check

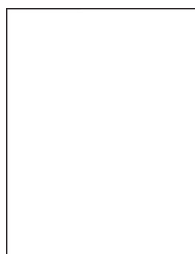

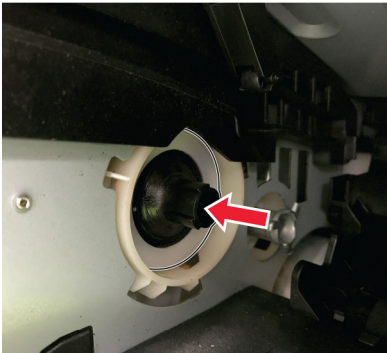
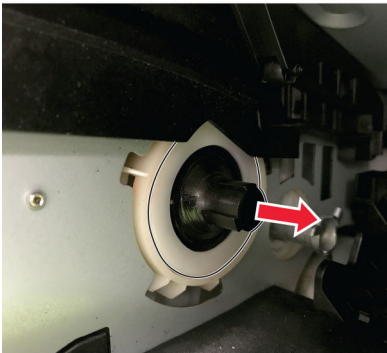

Actions	Yes	No
<p>Step 1 Check if the printer is using a genuine and supported Lexmark toner cartridge.</p> <p>Note: If the printer is using a third-party cartridge, then refer the users to their cartridge supplier.</p> <p>Is the printer using a genuine and supported toner cartridge?</p>	Go to step 3.	Go to step 2.
<p>Step 2 Install a genuine and supported toner cartridge.</p> <p>Does the problem remain?</p>	Go to step 3.	The problem is solved.
<p>Step 3</p> <ul style="list-style-type: none"> a Check and remove any packing material left on the imaging unit. b Firmly shake the imaging unit to redistribute the toner, and then reinstall it. <p>Does the problem remain?</p>	Go to step 4.	The problem is solved.
<p>Step 4 Check the imaging unit for damage and proper installation, and replace if necessary.</p> <p>Does the problem remain?</p>	Go to step 5.	The problem is solved.

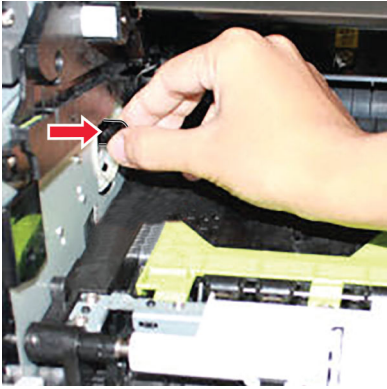
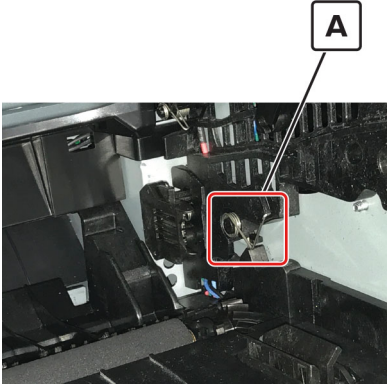
Actions	Yes	No
<p>Step 5</p> <p>Check the coupler to make sure that it is not stuck in the retracted position. While slowly closing the door, observe the coupler to see if it moves inward.</p> <p>Note: With the imaging unit removed, the coupler should retract with the door open and move inward when the front door is closed.</p>   <p>Is the coupler stuck, and not moving inward, while closing the front door?</p>	Go to step 6.	Go to step 7.

Actions	Yes	No
<p>Step 6 Reach inside the printer and manually reposition the coupler in the direction of the red arrow as shown.</p>  <p>Does the problem remain?</p>	Go to step 7.	The problem is solved.
<p>Step 7 Check if the imaging unit contact (A) is bent, damaged, or not in proper contact with the imaging unit.</p>  <p>Are the contacts free from damage, not bent and in proper contact with the imaging unit?</p>	Go to step 8.	Contact the next level of support.
<p>Step 8 Check all connections in the power supply. If necessary, replace the power supply.</p> <p>Does the problem remain?</p>	Go to step 9.	The problem is solved.
<p>Step 9 Reseat cable JPS1 on the controller board.</p> <p>Does the problem remain?</p>	Go to step 10.	The problem is solved.

Actions	Yes	No
<p>Step 10 Replace the cable.</p> <p>Does the problem remain?</p>	Go to step 11.	The problem is solved.
<p>Step 11</p> <p>a Check the transfer roller for proper installation. If necessary, remove and then reinstall the transfer roller.</p> <p>b Check the transfer roller for contamination and damage.</p> <p>Is the transfer roller free of contamination and damage?</p>	Go to step 13.	Go to step 12.
<p>Step 12 Replace the transfer roller. See “Transfer roll removal” on page 330.</p> <p>Does the problem remain?</p>	Go to step 13.	The problem is solved.

Actions	Yes	No
<p>Step 13</p> <p>a Check the coupler for signs of damage. The coupler is located on the main drive motor.</p> <ul style="list-style-type: none"> • Good condition  <ul style="list-style-type: none"> • Bad condition  <p>b If the coupler is damaged, then replace the main drive motor.</p> <p>Does the problem remain?</p>	<p>Go to step 14.</p>	<p>The problem is solved.</p>
<p>Step 14</p> <p>Depending on the printer model, reseal the following cables on the controller board:</p> <ul style="list-style-type: none"> • JVIDEO and JGLV1 (MS31x, MS41x, MS51x, and MS61x) • J6 and JLSU1 (MS610de and MX61xde) • JMM1 and JLSU1 (MX31x, MX41x, MX51x, and MX61x) <p>Does the problem remain?</p>	<p>Go to step 15.</p>	<p>The problem is solved.</p>
<p>Step 15</p> <p>Replace the laser printhead. See “Laser scanning unit (LSU) removal” on page 395.</p> <p>Does the problem remain?</p>	<p>Contact the next level of support.</p>	<p>The problem is solved.</p>

Print is too dark check

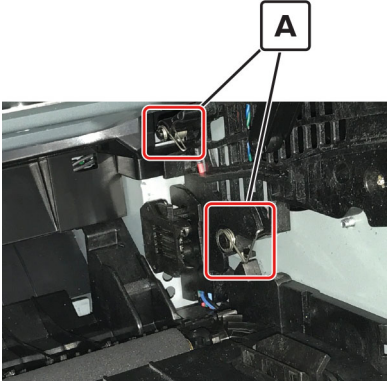

Actions	Yes	No
<p>Step 1</p> <p>Check if the printer is using a genuine and supported Lexmark toner cartridge.</p> <p>Note: If the printer is using a third-party cartridge, then refer the users to their cartridge supplier.</p> <p>Is the printer using a genuine and supported toner cartridge?</p>	Go to step 3.	Go to step 2.
<p>Step 2</p> <p>Install a genuine and supported toner cartridge.</p> <p>Does the problem remain?</p>	Go to step 3.	The problem is solved.
<p>Step 3</p> <p>a Turn off the printer, wait for 10 seconds, and then turn on the printer.</p> <p>b From the control panel, reduce the toner darkness in the Quality menu.</p> <p>Note: 8 is the factory default setting.</p> <p>Does the problem remain?</p>	Go to step 4.	The problem is solved.
<p>Step 4</p> <p>From the control panel, set the paper type, texture, and weight in the Paper menu to match the paper loaded.</p> <p>Does the problem remain?</p>	Go to step 5.	The problem is solved.
<p>Step 5</p> <p>Depending on the operating system, specify the paper type, texture, and weight from Printing Preferences or Print dialog.</p> <p>Does the problem remain?</p>	Go to step 6.	The problem is solved.
<p>Step 6</p> <p>a Check if the paper loaded has texture or rough finishes.</p> <p>b From the control panel, set the paper texture in the Paper menu to match the texture of the paper loaded.</p> <p>Does the problem remain?</p>	Go to step 7.	The problem is solved.

Actions	Yes	No
<p>Step 7 Make sure that the paper loaded is from a fresh package. Note: Paper absorbs moisture due to high humidity. Store paper in its original wrapper until you use it.</p> <p>Does the problem remain?</p>	Go to step 8.	The problem is solved.
<p>Step 8 Replace the imaging unit.</p> <p>Does the problem remain?</p>	Go to step 9.	The problem is solved.
<p>Step 9 Check if the imaging unit contacts (A) are bent, damaged, or not in proper contact with the imaging unit.</p> <div data-bbox="380 730 764 1108" style="text-align: center;">  </div> <p>Are the contacts free from damage, not bent and in proper contact with the imaging unit?</p>	Go to step 10.	Contact the next level of support.
<p>Step 10 Check all connections on the power supply for proper connection.</p> <p>Is the power supply properly connected?</p>	Contact the next level of support.	Go to step 11.
<p>Step 11 Replace the connections.</p> <p>Does the problem remain?</p>	Go to step 12.	The problem is solved.
<p>Step 12 Replace the power supply. See “Power supply removal” on page 361.</p> <p>Does the problem remain?</p>	Contact the next level of support.	The problem is solved.

Print is too light check

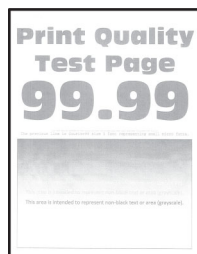

Actions	Yes	No
<p>Step 1</p> <p>Check if the printer is using a genuine and supported Lexmark toner cartridge.</p> <p>Note: If the printer is using a third-party cartridge, then refer the users to their cartridge supplier.</p> <p>Is the printer using a genuine and supported toner cartridge?</p>	Go to step 3.	Go to step 2.
<p>Step 2</p> <p>Install a genuine and supported toner cartridge.</p> <p>Does the problem remain?</p>	Go to step 3.	The problem is solved.
<p>Step 3</p> <p>a Turn off the printer, wait for 10 seconds, and then turn on the printer.</p> <p>b From the control panel:</p> <ol style="list-style-type: none"> 1 Increase the toner darkness in the Quality menu. Note: 8 is the factory default setting. 2 Set the paper type, texture, and weight in the Paper menu to match the paper loaded. <p>Does the problem remain?</p>	Go to step 4.	The problem is solved.
<p>Step 4</p> <ol style="list-style-type: none"> a Remove the toner cartridge and imaging unit. b Push either side of the transfer roller, located below the imaging unit, to check if it depresses and bounces back into place. c If the transfer roller does not depress and bounce back into place, then reinstall it by pulling up the blue gear and pulling it out from the right side to the left. d Firmly shake the imaging unit to redistribute the toner, and then reinstall it. e Reinstall the toner cartridge. f Turn off the printer, wait for 10 seconds, and then turn on the printer. <p>Does the problem remain?</p>	Go to step 5.	The problem is solved.

Actions	Yes	No
<p>Step 5 Check the shutter on the imaging unit for signs of damage. Note: The shutter opens to receive toner from the toner cartridge.</p> <p>Is the shutter on the imaging unit working properly?</p>	Go to step 6.	Go to step 7.
<p>Step 6 a Check the status of the imaging unit. 1 From the home screen, select Status/supplies. 2 Select View Supplies. b Check the condition of the imaging unit.</p> <p>Is the imaging unit near end of life and/or showing signs toner leakage?</p>	Go to step 7.	Go to step 8.
<p>Step 7 Replace the imaging unit.</p> <p>Does the problem remain?</p>	Go to step 8.	The problem is solved.
<p>Step 8 Replace the transfer roller. See “Transfer roll removal” on page 330.</p> <p>Does the problem remain?</p>	Go to step 9.	The problem is solved.
<p>Step 9 Clean the printhead lens. See “Cleaning the printhead lenses” on page 483.</p> <p>Note: This is applicable only to models installed with a galvo LSU. To determine whether the LSU is galvo, check the serial number of the printer. The sixth digit character assigned should be in the 0–9 or B–N range (Example: 4514 20HH 007CR).</p> <p>Does the problem remain?</p>	Go to step 10.	The problem is solved.
<p>Step 10 Replace the power supply. See “Power supply removal” on page 361.</p> <p>Does the problem remain?</p>	Go to step 11.	The problem is solved.
<p>Step 11 Check the cartridge gearbox for damage.</p> <p>Is the cartridge gearbox free from damage?</p>	Go to step 13.	Go to step 12.

Actions	Yes	No
<p>Step 12 Replace the cartridge gearbox. See “Cartridge gearbox removal” on page 312.</p> <p>Does the problem remain?</p>	Go to step 13.	The problem is solved.
<p>Step 13 Check connection JCART1 on the controller board and the connection on the cartridge gearbox.</p> <p>Are the connections properly connected?</p>	Go to step 15.	Go to step 14.
<p>Step 14 Replace the connections.</p> <p>Does the problem remain?</p>	Go to step 15.	The problem is solved.
<p>Step 15 Replace the cartridge gearbox. See “Cartridge gearbox removal” on page 312.</p> <p>Does the problem remain?</p>	Go to step 16.	The problem is solved.
<p>Step 16 Replace the controller board. See “Controller board removal” on page 320.</p> <p>Does the problem remain?</p>	Contact the next level of support.	The problem is solved.

Paper curl check



Actions	Yes	No
<p>Step 1 Check if the printer is using a genuine and supported Lexmark toner cartridge.</p> <p>Note: If the printer is using a third-party cartridge, then refer the users to their cartridge supplier.</p> <p>Is the printer using a genuine and supported toner cartridge?</p>	Go to step 3.	Go to step 2.
<p>Step 2 Install a genuine and supported toner cartridge.</p> <p>Does the problem remain?</p>	Go to step 3.	The problem is solved.
<p>Step 3 Adjust the guides in the tray to the correct position for the paper loaded.</p> <p>Does the problem remain?</p>	Go to step 4.	The problem is solved.
<p>Step 4 From the control panel, set the paper size, type, and weight in the Paper menu to match the paper loaded.</p> <p>Does the problem remain?</p>	Go to step 5.	The problem is solved.
<p>Step 5 Depending on the operating system, specify the paper size from Printing Preferences or Print dialog.</p> <p>Does the problem remain?</p>	Go to step 6.	The problem is solved.
<p>Step 6 Remove paper from the tray, and then turn it over.</p> <p>Does the problem remain?</p>	Go to step 7.	The problem is solved.
<p>Step 7 Make sure that the paper loaded is from a fresh package.</p> <p>Note: Paper absorbs moisture due to high humidity. Store paper in its original wrapper until you use it.</p> <p>Does the problem remain?</p>	Go to step 8.	The problem is solved.
<p>Step 8 Make sure that the printer supports the paper loaded.</p> <p>Is the paper supported?</p>	Contact the next level of support.	Go to step 9.

Actions	Yes	No
<p>Step 9 Load a supported paper.</p> <p>Does the problem remain?</p>	Contact the next level of support.	The problem is solved.

Folded or wrinkled paper check



Actions	Yes	No
<p>Step 1</p> <p>a Check if the printer is using a non-Lexmark toner cartridge. Note: If the printer is using a third-party cartridge, then do not replace the imaging unit. Refer the users to their cartridge supplier.</p> <p>b Make sure that the toner cartridge is compatible with the imaging unit.</p> <p>Does the problem remain?</p>	Go to step 2.	The problem is solved.
<p>Step 2</p> <p>a Check if the paper loaded is from a fresh package. Note: The amount of moisture in paper affects both print quality and printer ability to feed paper correctly.</p> <p>b Make sure that the printer supports the paper loaded. For a complete list of supported paper, see the printer <i>User's Guide</i>.</p> <p>Does the problem remain?</p>	Go to step 3.	The problem is solved.
<p>Step 3</p> <p>Make sure that the fuser entry guide is free of waste toner and dust. Warning—Potential Damage: Clean the fuser entry guide with a toner vacuum and cloth. Do not use compressed air.</p> <p>Does the problem remain?</p>	Go to step 4.	The problem is solved.
<p>Step 4</p> <p>If the fuser has reached end of life, then replace the maintenance kit.</p> <p>Does the problem remain?</p>	Contact the next level of support.	The problem is solved.

Solid black pages check

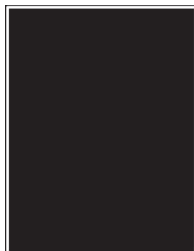

Actions	Yes	No
<p>Step 1 Check if the printer is using a genuine and supported Lexmark toner cartridge.</p> <p>Note: If the printer is using a third-party cartridge, then refer the users to their cartridge supplier.</p> <p>Is the printer using a genuine and supported toner cartridge?</p>	Go to step 3.	Go to step 2.
<p>Step 2 Install a genuine and supported toner cartridge.</p> <p>Does the problem remain?</p>	Go to step 3.	The problem is solved.

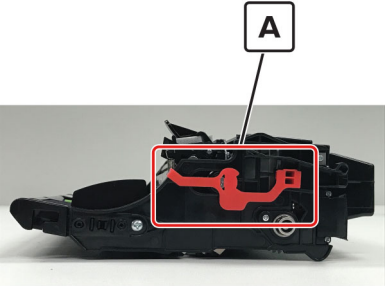
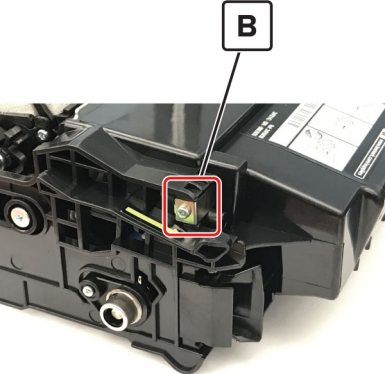
Actions	Yes	No
<p>Step 3</p> <p>a Remove any packing material left on the imaging unit, including the red separator plastic (A).</p>  <p>Note: You may need a pair of pliers to remove a piece of broken plastic inside the imaging unit.</p> <p>b Check the charge roller contact (B) on the right side of the imaging unit for damage and contamination.</p>  <p>Is the charge roller contact damaged and contaminated?</p>	Go to step 4.	Go to step 5.
<p>Step 4</p> <p>Repair or replace the charge roller contact on the imaging unit.</p> <p>Does the problem remain?</p>	Go to step 5.	The problem is solved.
<p>Step 5</p> <p>Replace the imaging unit.</p> <p>Does the problem remain?</p>	Go to step 6.	The problem is solved.

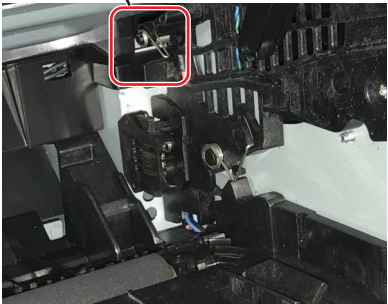
Actions	Yes	No
<p>Step 6 Check if the imaging unit contact (C) is contaminated, broken, or bent out of proper position.</p> <div data-bbox="381 331 766 716" style="text-align: center;">  </div> <p>Is the contact contaminated, broken, or bent out of proper position?</p>	Go to step 7.	Go to step 8.
<p>Step 7 Clean or repair the imaging unit contacts.</p> <p>Does the problem remain?</p>	Contact the next level of support.	The problem is solved.
<p>Step 8 Check the high voltage metal contacts on the imaging unit for damage. If necessary, replace the imaging unit.</p> <p>Does the problem remain?</p>	Go to step 9.	The problem is solved.
<p>Step 9 Check cable JPS1 from the controller board to the power supply for proper connection.</p> <p>Is the cable properly connected?</p>	Go to step 11.	Go to step 10.
<p>Step 10 Reseat the cable.</p> <p>Does the problem remain?</p>	Go to step 11.	The problem is solved.
<p>Step 11 Replace the cable.</p> <p>Does the problem remain?</p>	Contact the next level of support.	The problem is solved.

Repeating defects check



Actions	Yes	No
<p>Step 1</p> <p>a From the control panel, navigate to: Menu > Help > Print Defects Guide</p> <p>b Using the Print Defects Guide, check if the distance between the defects is equal to any of the following:</p> <ul style="list-style-type: none"> • 3.82 in. (97 mm) • 1.85 in. (47 mm) • 1.5 in. (38 mm) <p>Note: Make sure to measure the defect interval accurately.</p> <p>Does the distance measured match any of the items listed?</p>	Go to step 2.	Go to step 3.
<p>Step 2</p> <p>Replace the imaging unit.</p> <p>Does the problem remain?</p>	Go to step 3.	The problem is solved.
<p>Step 3</p> <p>Check if the distance between repeating defects is equal to 3.15 inches (85 mm).</p> <p>Does the distance between repeating defects equal to 3.15 inches (85 mm)?</p>	Go to step 4.	Contact the next level of support.
<p>Step 4</p> <p>Replace the fuser. See “Fuser removal” on page 386.</p> <p>Does the problem remain?</p>	Go to step 5.	The problem is solved.
<p>Step 5</p> <p>Replace the transfer roller. See “Transfer roll removal” on page 330.</p> <p>Does the problem remain?</p>	Contact the next level of support.	The problem is solved.

Skewed print check



Actions	Yes	No
<p>Step 1 Check the guides in the tray where the skewed prints are sourced from.</p> <p>Note: If paper is sourced from the MPF, then proceed to step 9.</p> <p>Does the position of the guides match the paper loaded?</p>	Go to step 3.	Go to step 2.
<p>Step 2 Adjust the guides to match the paper loaded.</p> <p>Does the problem remain?</p>	Go to step 3.	The problem is solved.
<p>Step 3 Check if the printer supports the paper loaded.</p> <p>Note: For a complete list of supported paper, see the printer <i>User's Guide</i>.</p> <p>Is the paper supported?</p>	Go to step 5.	Go to step 4.
<p>Step 4 Remove the paper, and then load a supported one.</p> <p>Does the problem remain?</p>	Go to step 5.	The problem is solved.
<p>Step 5 Check the tray pick roller for excess wear and contamination.</p> <p>Is the pick roller free from excess wear and contamination?</p>	Go to step 7.	Go to step 6.
<p>Step 6 Replace the pick roller. See “Pick roller removal” on page 415.</p> <p>Does the problem remain?</p>	Go to step 7.	The problem is solved.

Actions	Yes	No
<p>Step 7 Perform a print test. From the Diagnostics menu, select PRINT TESTS > Tray [x]. Note: [x] refers to the tray where the skewed prints are sourced from.</p> <p>Does the problem remain?</p>	Go to step 8.	The problem is solved.
<p>Step 8 Adjust the margins. From the Diagnostic menu, select REGISTRATION.</p> <p>Does the problem remain?</p>	Go to step 15.	The problem is solved.
<p>Step 9 Check the guides in the MPF tray.</p> <p>Does the position of the guides match the paper loaded?</p>	Go to step 11.	Go to step 10.
<p>Step 10 Adjust the guides to match the paper loaded.</p> <p>Does the problem remain?</p>	Go to step 11.	The problem is solved.
<p>Step 11 Check if the printer supports the paper loaded. Note: For a complete list of supported paper, see the printer <i>User's Guide</i>.</p> <p>Is the paper supported?</p>	Go to step 13.	Go to step 12.
<p>Step 12 Remove the paper, and then load a supported one.</p> <p>Does the problem remain?</p>	Go to step 13.	The problem is solved.
<p>Step 13 Check the MPF pick roller for excess wear and contamination.</p> <p>Is the MPF pick roller free from excess wear and contamination?</p>	Go to step 15.	Go to step 14.
<p>Step 14 Replace the MPF pick roller. See “MPF pick roller removal” on page 352.</p> <p>Does the problem remain?</p>	Go to step 15.	The problem is solved.

Actions	Yes	No
<p>Step 15 Perform the paper skew adjustment. See “Printhead assembly adjustments” on page 299.</p> <p>Does the problem remain?</p>	Contact the next level of support.	The problem is solved.

Streaked vertical lines appear on prints check



Note: This check applies only to printer models with a hot roll fuser.

Actions	Yes	No
<p>Step 1 Check if the printer is using a genuine and supported Lexmark toner cartridge.</p> <p>Note: If the printer is using a third-party cartridge, then refer the users to their cartridge supplier.</p> <p>Is the printer using a genuine and supported toner cartridge?</p>	Go to step 3.	Go to step 2.
<p>Step 2 Install a genuine and supported toner cartridge.</p> <p>Does the problem remain?</p>	Go to step 3.	The problem is solved.
<p>Step 3 Using a blank piece of paper, make a two-sided (duplexed) copy using the ADF.</p> <p>Do vertical dark lines appear on the print exiting the printer?</p>	Go to step 4.	Go to step 5.

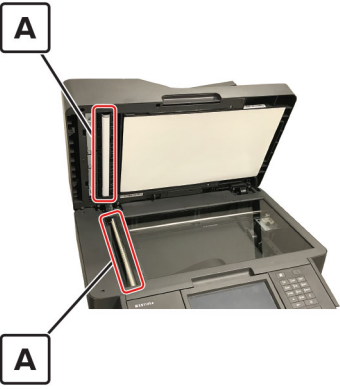
Actions	Yes	No
<p>Step 4 Clean the ADF scanner glass (A). See “Cleaning the scanner glass” on page 482.</p>  <p>Does the problem remain?</p>	Go to step 5.	The problem is solved.
<p>Step 5 Remove, and then reinstall the imaging unit.</p> <p>Does the problem remain?</p>	Go to step 6.	The problem is solved.
<p>Step 6 Replace the imaging unit.</p> <p>Does the problem remain?</p>	Go to step 7.	The problem is solved.
<p>Step 7 Remove the hot roll fuser, and then check for scratches and other damage.</p> <p>Is the fuser free of scratches and other damage?</p>	Contact the next level of support.	Go to step 8.
<p>Step 8 Replace the hot roll fuser.</p> <p>Does the problem remain?</p>	Contact the next level of support.	The problem is solved.

Horizontal light bands check



Actions	Yes	No
<p>Step 1 Check if the printer is using a genuine and supported Lexmark toner cartridge.</p> <p>Note: If the printer is using a third-party cartridge, then refer the users to their cartridge supplier.</p> <p>Is the printer using a genuine and supported toner cartridge?</p>	Go to step 3.	Go to step 2.
<p>Step 2 Install a genuine and supported toner cartridge.</p> <p>Does the problem remain?</p>	Go to step 3.	The problem is solved.
<p>Step 3 Turn off the printer, wait for 10 seconds, and then turn on the printer.</p> <p>Does the problem remain?</p>	Go to step 4.	The problem is solved.
<p>Step 4 Check the imaging unit contact block (A), including the white and red wires, for damage or improper installation.</p> <div data-bbox="380 930 764 1211" style="text-align: center;"> </div> <p>Is the imaging unit contact block free of damage and properly installed?</p>	Go to step 5.	Contact the next level of support.
<p>Step 5 Replace the power supply. See “Power supply removal” on page 361.</p> <p>Does the problem remain?</p>	Contact the next level of support.	The problem is solved.

Vertical light bands check



Actions	Yes	No
<p>Step 1 Check if the printer is using a genuine and supported Lexmark toner cartridge.</p> <p>Note: If the printer is using a third-party cartridge, refer the users to their cartridge supplier.</p> <p>Is the printer using a genuine and supported toner cartridge?</p>	Go to step 3.	Go to step 2.
<p>Step 2 Install a genuine and supported toner cartridge.</p> <p>Does the problem remain?</p>	Go to step 3.	The problem is solved.
<p>Step 3 Clean the printhead lens. See “Cleaning the printhead lenses” on page 483.</p> <p>Note: This is applicable only to models installed with a galvo LSU. To determine whether the LSU is galvo, check the serial number of the printer. The sixth digit character assigned should be in the 0–9 or B–N range (Example: 4514 20HH 007CR).</p> <p>Does the problem remain?</p>	Go to step 4.	The problem is solved.
<p>Step 4 Replace the printhead. See “Laser scanning unit (LSU) removal” on page 395.</p> <p>Does the problem remain?</p>	Go to step 5.	The problem is solved.
<p>Step 5 Replace the imaging unit.</p> <p>Does the problem remain?</p>	Contact the next level of support.	The problem is solved.

Vertical dark bands check

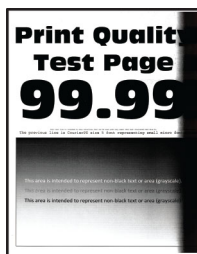

Actions	Yes	No
<p>Step 1 Check if the printer is using a genuine and supported Lexmark toner cartridge.</p> <p>Note: If the printer is using a third-party cartridge, then refer the users to their cartridge supplier.</p> <p>Is the printer using a genuine and supported toner cartridge?</p>	Go to step 3.	Go to step 2.
<p>Step 2 Install a genuine and supported toner cartridge.</p> <p>Does the problem remain?</p>	Go to step 3.	The problem is solved.
<p>Step 3 Remove, and then reinstall the toner cartridge and imaging unit.</p> <p>Does the problem remain?</p>	Go to step 4.	The problem is solved.
<p>Step 4 If a bright light enters the right side of the printer, then move the printer to avoid the bright light.</p> <p>Note: In cases where the printer cannot be moved or relocated, add a cover to the fan inlet vent to block the light from entering the printer, or contact the next level of support.</p> <p>Does the problem remain?</p>	Go to step 5.	The problem is solved.

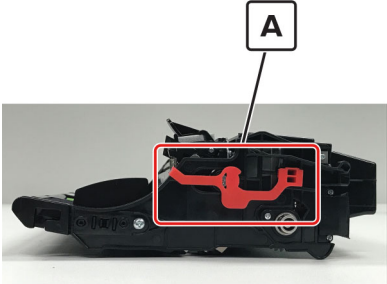
Actions	Yes	No
<p>Step 5 If a separator plastic (A) is stuck inside the imaging unit or if there are other obstructions between the charge roller and photoconductor drum, then remove them.</p>  <p>Does the problem remain?</p>	Contact the next level of support.	The problem is solved.

Vertical dark streaks with print missing check

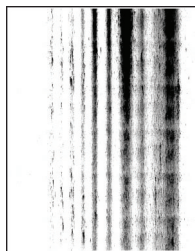

Actions	Yes	No
<p>Step 1 Check if the printer is using a genuine and supported Lexmark toner cartridge.</p> <p>Note: If the printer is using a third-party cartridge, then refer the users to their cartridge supplier.</p> <p>Is the printer using a genuine and supported toner cartridge?</p>	Go to step 3.	Go to step 2.
<p>Step 2 Install a genuine and supported toner cartridge.</p> <p>Does the problem remain?</p>	Go to step 3.	The problem is solved.

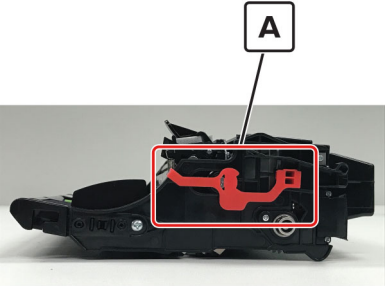
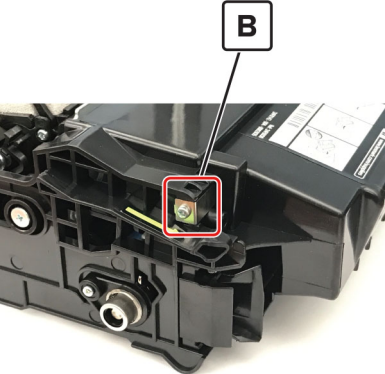
Actions	Yes	No
<p>Step 3</p> <p>a Remove any packing material left on the imaging unit, including the red separator plastic (A).</p>  <p>Note: You may need a pair of pliers to remove a piece of broken plastic inside the imaging unit.</p> <p>b Check the charge roller contact (B) on the right side of the imaging unit for damage and proper installation.</p>  <p>Is the charge roller contact damaged and contaminated?</p>	Go to step 4.	Go to step 5.
<p>Step 4</p> <p>Repair or replace the charge roller contact on the imaging unit.</p> <p>Does the problem remain?</p>	Go to step 5.	The problem is solved.
<p>Step 5</p> <p>Replace the imaging unit.</p> <p>Does the problem remain?</p>	Go to step 6.	The problem is solved.

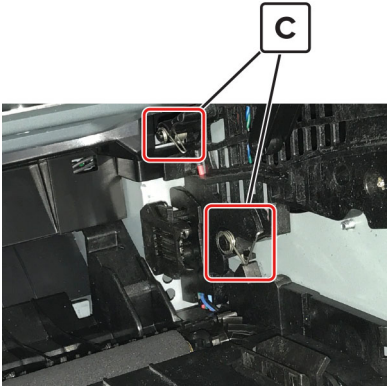
Actions	Yes	No
<p>Step 6 Check if the imaging unit contacts (C) are contaminated or bent out of proper position.</p>  <p>Are the contacts contaminated and bent out of proper position?</p>	Go to step 7.	Go to step 8.
<p>Step 7 Clean or repair the imaging unit contacts.</p> <p>Does the problem remain?</p>	Go to step 8.	The problem is solved.
<p>Step 8 Check connection JPS1 on the controller board and the connections on the power supply.</p> <p>Are the connections properly connected?</p>	Go to step 10.	Go to step 9.
<p>Step 9 Reconnect the cables.</p> <p>Does the problem remain?</p>	Go to step 10.	The problem is solved.
<p>Step 10 Replace the power supply. See “Power supply removal” on page 361.</p> <p>Does the problem remain?</p>	Contact the next level of support.	The problem is solved.

White streaks and voided areas check

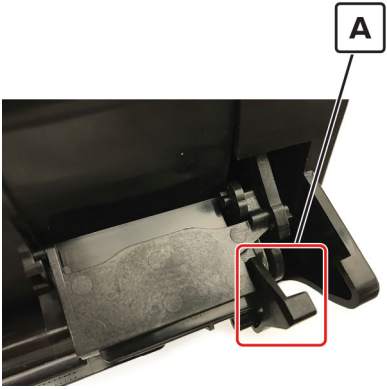
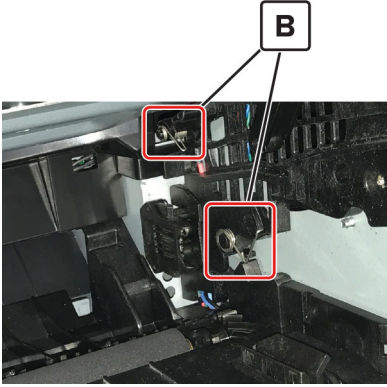

Actions	Yes	No
<p>Step 1 Check if the printer is using a genuine and supported Lexmark toner cartridge.</p> <p>Note: If the printer is using a third-party cartridge, do not replace the imaging unit. Refer the users to their cartridge supplier.</p> <p>Is the printer using a genuine and supported toner cartridge?</p>	Go to step 3.	Go to step 2.
<p>Step 2 Install a genuine and supported toner cartridge.</p> <p>Does the problem remain?</p>	Go to step 3.	The problem is solved.
<p>Step 3 Set the paper type and weight settings in the Paper menu to match the paper loaded.</p> <p>Note: Make sure that the printer supports the paper loaded. For a complete list of supported paper, see the printer <i>User's Guide</i>.</p> <p>Does the problem remain?</p>	Go to step 4.	The problem is solved.
<p>Step 4</p> <ul style="list-style-type: none"> a Update the firmware to the latest version available. b Enter the Diagnostics menu, and then change the EngSetting 14 value to 48. Note: You can also change the setting through a bundle file or NPA command. c Set Quiet mode to Off. d Review the Event Log Summary sheets and check if either error code 31.46 or 31.66 events occurred for the imaging unit. If they did, check if they are occurring with the current toner cartridge. <p>Does the problem remain?</p>	Go to step 5.	The problem is solved.

Actions	Yes	No
<p>Step 5 Check the shutter tab (A) on the toner cartridge for signs of damage.</p>  <p>Is the shutter tab damaged?</p>	Go to step 6.	Go to step 7.
<p>Step 6 Replace the imaging unit and the toner cartridge.</p> <p>Does the problem remain?</p>	Go to step 7.	The problem is solved.
<p>Step 7 Clean the printhead lens. See “Cleaning the printhead lenses” on page 483.</p> <p>Note: This is applicable only to models installed with a galvo LSU. To determine whether the LSU is galvo, check the serial number of the printer. The sixth digit character assigned should be in the 0–9 or B–N range (Example: 4514 20HH 007CR).</p> <p>Does the problem remain?</p>	Go to step 8.	The problem is solved.
<p>Step 8 Check if the imaging unit contacts (B) are contaminated or bent out of proper position.</p>  <p>Are the contacts contaminated or bent out of proper position?</p>	Go to step 9.	Go to step 10.

Actions	Yes	No
<p>Step 9 Clean or repair the imaging unit contacts.</p> <p>Does the problem remain?</p>	Contact the next level of support.	The problem is solved.
<p>Step 10 Check connection JPS1 on the controller board and all the connections on the power supply.</p> <p>Are the connections properly connected?</p>	Go to step 12.	Go to step 11.
<p>Step 11 Replace the connections.</p> <p>Does the problem remain?</p>	Go to step 12.	The problem is solved.
<p>Step 12 Replace the power supply. See “Power supply removal” on page 361.</p> <p>Does the problem remain?</p>	Go to step 13.	The problem is solved.
<p>Step 13 Replace the printhead. See “Laser scanning unit (LSU) removal” on page 395.</p> <p>Does the problem remain?</p>	Contact the next level of support.	The problem is solved.

Fine lines are not printed correctly (specifically Chinese characters) check



Actions	Yes	No
<p>Step 1 Check if the printer is using a genuine and supported Lexmark toner cartridge.</p> <p>Note: If the printer is using a third-party cartridge, then refer the users to their cartridge supplier.</p> <p>Is the printer using a genuine and supported toner cartridge?</p>	Go to step 3.	Go to step 2.
<p>Step 2 Install a genuine and supported toner cartridge.</p> <p>Does the problem remain?</p>	Go to step 3.	The problem is solved.
<p>Step 3 From the control panel, adjust the Toner Darkness setting to 7.</p> <p>a From the Settings menu, navigate to: Print Settings > Quality menu > Pixel Boost > Fonts > Submit</p> <p>b From the Quality menu, select Toner Darkness, and then adjust the setting to 7.</p> <p>c Submit the changes.</p> <p>Note: Adjusting the Toner Darkness setting to 7 results in a slightly lighter print. You may leave the Toner Darkness value at 8 in order to maintain the darkness that you have grown accustomed to, but this will result in reduced toner yield.</p> <p>Does the problem remain?</p>	Contact the next level of support.	The problem is solved.

Clipped pages or images check

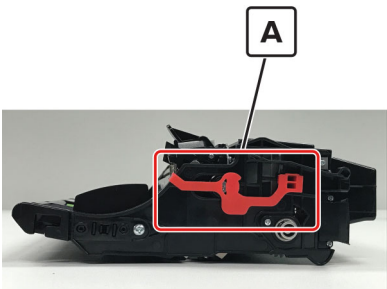

Actions	Yes	No
<p>Step 1 Check if the printer is using a genuine and supported Lexmark toner cartridge.</p> <p>Note: If the printer is using a third-party cartridge, then refer the users to their cartridge supplier.</p> <p>Is the printer using a genuine and supported toner cartridge?</p>	Go to step 3.	Go to step 2.
<p>Step 2 Install a genuine and supported toner cartridge.</p> <p>Does the problem remain?</p>	Go to step 3.	The problem is solved.
<p>Step 3 Remove, and then reinstall the imaging unit.</p> <p>Does the problem remain?</p>	Go to step 4.	The problem is solved.
<p>Step 4 Check if a separator plastic (A), or a piece of it, is stuck inside the imaging unit or if there are any other obstructions between the charge roller and photoconductor drum.</p> <div data-bbox="380 961 764 1247" style="text-align: center;">  </div> <p>Is the imaging unit free from any separator plastic fragments or other obstructions?</p>	Go to step 6.	Go to step 5.
<p>Step 5 Using a pair of pliers, remove the separator plastic fragments and other obstructions.</p> <p>Does the problem remain?</p>	Go to step 6.	The problem is solved.
<p>Step 6 Replace the imaging unit.</p> <p>Does the problem remain?</p>	Go to step 7.	The problem is solved.

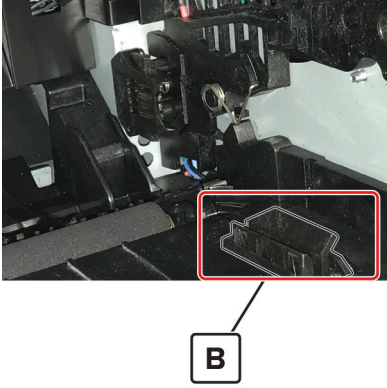
Actions	Yes	No
<p>Step 7 Check the imaging unit contact block (B) for damage or improper installation.</p>  <p>Is the imaging unit contact block damaged or improperly installed?</p>	Go to step 8.	Contact the next level of support.
<p>Step 8 Reinstall or replace the imaging unit contact block.</p> <p>Does the problem remain?</p>	Contact the next level of support.	The problem is solved.

Compressed images appear on prints check

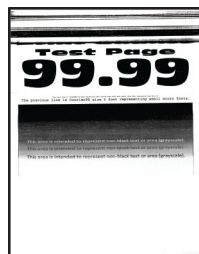

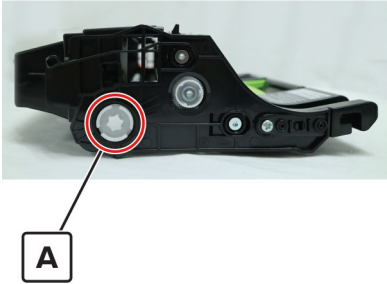
Actions	Yes	No
<p>Step 1 Remove the imaging unit, and then inspect the white photoconductor coupler (A). The coupler should be firmly connected to the imaging unit and should not freely rotate.</p>  <p>Does the coupler move freely or appear damaged?</p>	Go to step 2.	Go to step 3.
<p>Step 2 Replace the imaging unit.</p> <p>Does the problem remain?</p>	Go to step 3.	The problem is solved.
<p>Step 3 Replace the main drive gearbox. See “Main drive gearbox removal” on page 304.</p> <p>Does the problem remain?</p>	Contact the next level of support.	The problem is solved.

Incorrect margins on prints check



Actions	Yes	No
<p>Step 1 Adjust the guides in the tray according to the size of the paper loaded.</p> <p>Does the problem remain?</p>	Go to step 2.	The problem is solved.
<p>Step 2 Do one of the following:</p> <ul style="list-style-type: none"> • From the printer control panel, set the paper size in the Paper menu to match the paper loaded in the tray. • Change the paper loaded in the tray to match the paper size specified in the tray settings. <p>Does the problem remain?</p>	Go to step 3.	The problem is solved.
<p>Step 3 Depending on your operating system, specify the paper size from Printing Preferences or from the Print dialog.</p> <p>Does the problem remain?</p>	Go to step 4 or contact the next level of support.	The problem is solved.
<p>Step 4</p> <ol style="list-style-type: none"> a Enter the Diagnostics menu, and then select Registration. b Adjust the margins as necessary. <p>Does the problem remain?</p>	Contact the next level of support.	The problem is solved.

Toner rubs off check

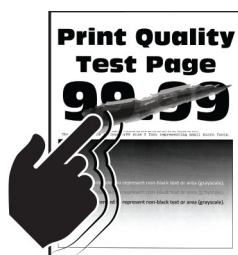

Actions	Yes	No
<p>Step 1 Check if the printer is using a genuine and supported Lexmark toner cartridge.</p> <p>Note: If the printer is using a third-party cartridge, then refer the users to their cartridge supplier.</p> <p>Is the printer using a genuine and supported toner cartridge?</p>	Go to step 3.	Go to step 2.
<p>Step 2 Install a genuine and supported toner cartridge.</p> <p>Does the problem remain?</p>	Go to step 3.	The problem is solved.
<p>Step 3 From the control panel, set the paper type, texture, and weight in the Paper menu to match the paper loaded.</p> <p>Does the problem remain?</p>	Go to step 4.	The problem is solved.
<p>Step 4 Remove, and then reinstall the fuser.</p> <p>Does the problem remain?</p>	Go to step 5.	The problem is solved.
<p>Step 5 Replace the fuser. See “Fuser removal” on page 386.</p> <p>Does the problem remain?</p>	Go to step 6.	The problem is solved.
<p>Step 6 Reseat the connections on the power supply.</p> <p>Does the problem remain?</p>	Go to step 7.	The problem is solved.
<p>Step 7 Replace the power supply. See “Power supply removal” on page 361.</p> <p>Does the problem remain?</p>	Contact the next level of support.	The problem is solved.

Toner specks appear on prints check



Actions	Yes	No
<p>Step 1 Check if the printer is using a genuine and supported Lexmark toner cartridge.</p> <p>Note: If the printer is using a third-party cartridge, then refer the users to their cartridge supplier.</p> <p>Is the printer using a genuine and supported toner cartridge?</p>	Go to step 3.	Go to step 2.
<p>Step 2 Install a genuine and supported toner cartridge.</p> <p>Does the problem remain?</p>	Go to step 3.	The problem is solved.
<p>Step 3</p> <p>a Check the status of the imaging unit.</p> <ol style="list-style-type: none"> 1 From the home screen, select Status/supplies. 2 Select View Supplies. <p>b Check the condition of the imaging unit.</p> <p>Is the imaging unit near end of life and/or showing signs of toner leakage?</p>	Go to step 4.	Go to step 5.
<p>Step 4 Replace the imaging unit.</p> <p>Does the problem remain?</p>	Go to step 5.	The problem is solved.
<p>Step 5 Check if toner specks appear only on the edges or back side of the pages.</p> <p>Do toner specks appear only on the edges or back side of the pages?</p>	Go to step 6.	Go to step 7.
<p>Step 6 Replace the transfer roller. See “Transfer roll removal” on page 330.</p> <p>Does the problem remain?</p>	Go to step 7.	The problem is solved.
<p>Step 7 Check the printer for stray toner contamination.</p> <p>Is the printer contaminated with stray toner?</p>	Go to step 8.	Contact the next level of support.
<p>Step 8 Using an approved toner vacuum cleaner, completely clean the printer, toner cartridge, and imaging unit of toner contamination.</p> <p>Does the problem remain?</p>	Contact the next level of support.	The problem is solved.

Paper jams

- “Avoiding jams” on page 89
- “Understanding jam messages and locations” on page 90
- “200 paper jams” on page 91
- “201 paper jams” on page 101
- “202 paper jams” on page 102
- “23y paper jams” on page 105
- “241 paper jams” on page 107
- “242–244 paper jams” on page 112
- “25y paper jams” on page 121
- “28y paper jams” on page 124
- “29y paper jams” on page 128
- “45y paper jams” on page 129

Avoiding jams

Load paper properly

- Make sure that the paper lies flat in the tray.
- Do not remove a tray while the printer is printing.
- Do not load a tray while the printer is printing. Load it before printing, or wait for a prompt to load it.
- Do not load too much paper. Make sure that the stack height is below the maximum paper fill indicator.
- Do not slide paper into the tray. Load paper as shown in the illustration.

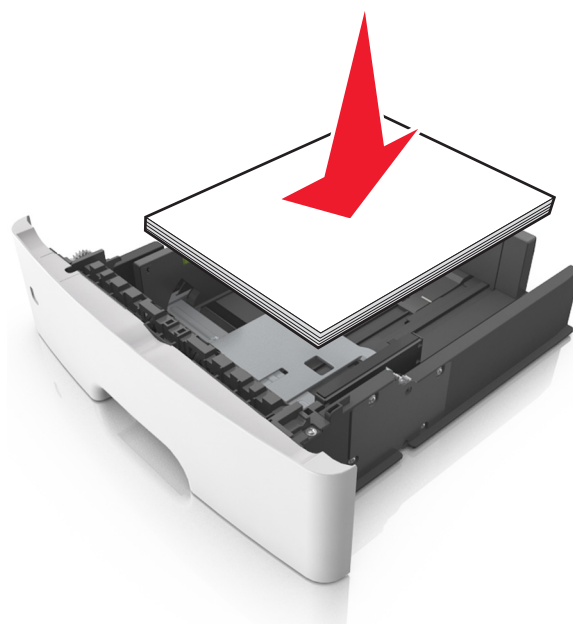

- Make sure that the paper guides are properly positioned.
- Push the tray firmly into the printer after loading paper.

Use recommended paper

- Use only recommended paper or specialty media.
- Do not load wrinkled, creased, damp, bent, or curled paper.
- Flex, fan, and straighten paper before loading it.

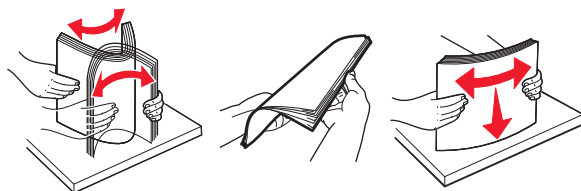

- Do not use paper that has been cut or trimmed by hand.
- Do not mix paper sizes, weights, or types in the same tray.
- Make sure that the paper size and type are set correctly on the Embedded Web Server or the computer.

Note: Depending on your operating system, access the Paper menu using Local Printer Settings Utility or Printer Settings.

- Store paper according to manufacturer recommendations.

Understanding jam messages and locations

When a jam occurs, a message indicating the jam location and information to clear the jam appears on the printer display. Open the doors, covers, and trays indicated on the display to remove the jam.

Notes:

- When Jam Assist is set to On, the printer automatically flushes blank pages or pages with partial prints to the standard bin after a jammed page has been cleared. Check your printed output stack for discarded pages.
- When Jam Recovery is set to On or Auto, the printer reprints jammed pages. However, the Auto setting does not guarantee that the page will print.



	Jam access area	Printer control panel message	What to do
1	Automatic document feeder (ADF)	[x]-page jam, open ADF to clear jam. [28y.xx]	Remove all paper from the ADF tray, and then remove the jammed paper.
2	Standard bin	[x]-page jam, clear standard bin. [20y.xx]	Remove the jammed paper.
3	Front door	[x]-page jam, open front door. [20y.xx]	Open the front door, then remove the toner cartridge and imaging unit, and then the jammed paper.
4	Multipurpose feeder	[x]-page jam, clear manual feeder. [25y.xx]	Remove all paper from the multipurpose feeder, and then remove the jammed paper.
5	Tray 1	[x]-page jam, remove tray 1 to clear duplex. [23y.xx]	Pull out tray 1 completely, then push the front duplex flap down, and then remove the jammed paper. Note: You may need to open the rear door to clear some 23y.xx paper jams.
6	Tray [x]	[x]-page jam, open tray [x]. [24y.xx]	Pull the indicated tray out, and then remove the jammed paper.
7	Rear door	[x]-page jam, open rear door. [20y.xx]	Open the rear door, and then remove the jammed paper.
8	Finisher rear door	[x]-page jam, remove all pages from the finisher's accumulator. Leave paper in bin [45y.xx]	<ul style="list-style-type: none"> • Open the finisher rear door, and then remove the jammed paper. • Open the trap door, and then remove the jammed paper.
9	Finisher output bin	[x]-page jam, remove all pages from the output bin. Leave paper in bin [45y.xx]	<ul style="list-style-type: none"> • Move the left tamper arm to the left and the right tamper arm to the right, and then remove the jammed paper from the finisher bin. • Open the finisher rear door and the trap door, and then remove any jammed pages.

200 paper jams

[x]-page jam, clear standard bin. [20y.xx]

- 1 Firmly grasp the jammed paper on each side, and then gently pull it out.

Note: Make sure all paper fragments are removed.

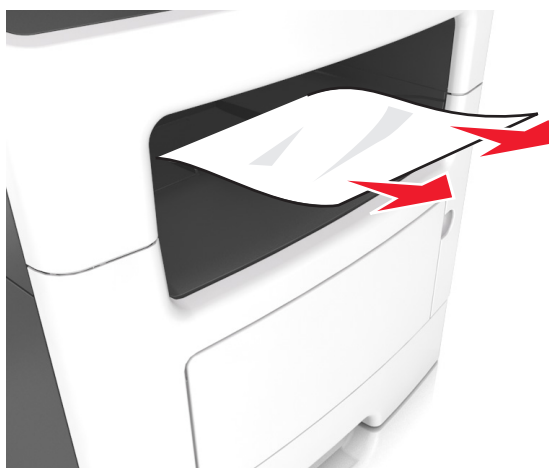

2 From the printer control panel, touch **Done** to clear the message and continue printing.

[x]-page jam, open front door. [20y.xx]

 **CAUTION—HOT SURFACE:** The inside of the printer might be hot. To reduce the risk of injury from a hot component, allow the surface to cool before touching it.

1 Press the button on the right side of the printer, and then open the front door.

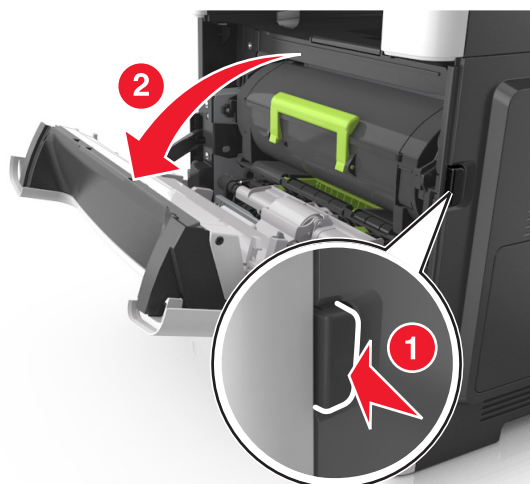

2 Pull out the toner cartridge using the handle.

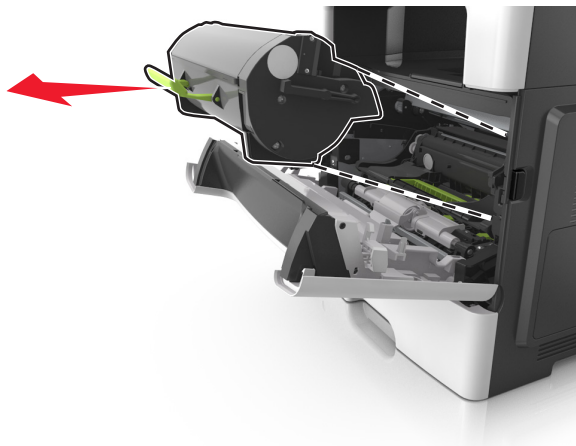

3 Lift the green handle, and then pull out the imaging unit from the printer.

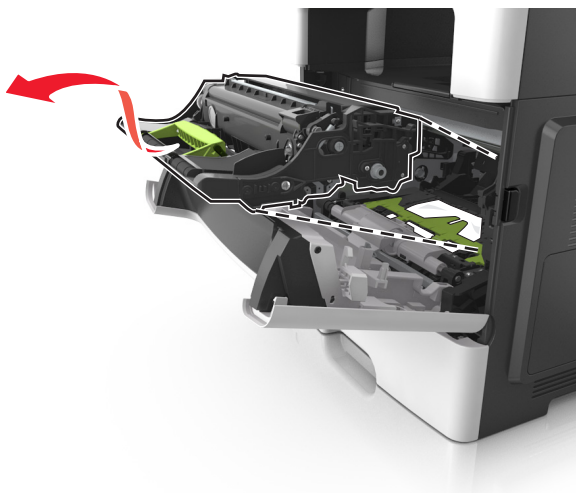

Warning—Potential Damage: Do not touch the shiny blue photoconductor drum under the imaging unit. Doing so may affect the quality of future print jobs.

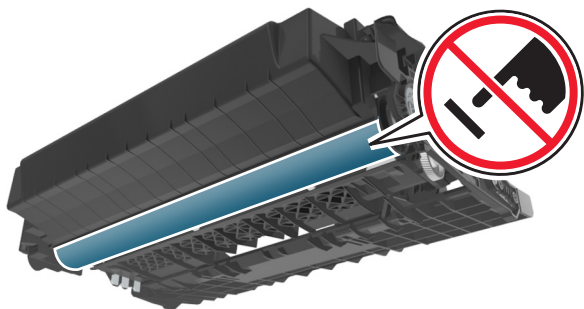

- 4 Lift the green flap in front of the printer.

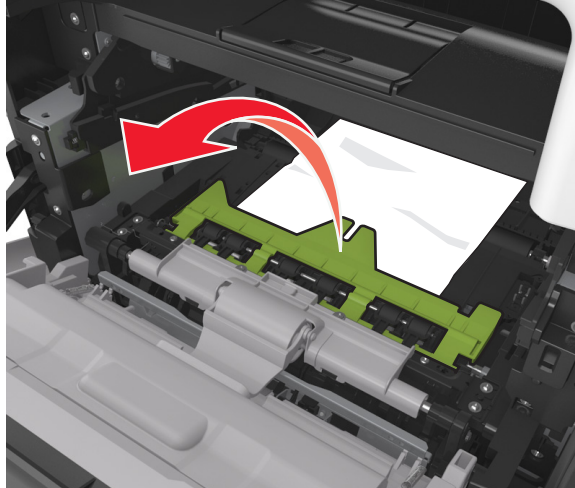

- 5 Place the imaging unit aside on a flat, smooth surface.

Warning—Potential Damage: Do not expose the imaging unit to direct light for more than 10 minutes. Extended exposure to light may cause print quality problems.

- 6 Firmly grasp the jammed paper on each side, and then gently pull it out.

Note: Make sure all paper fragments are removed.

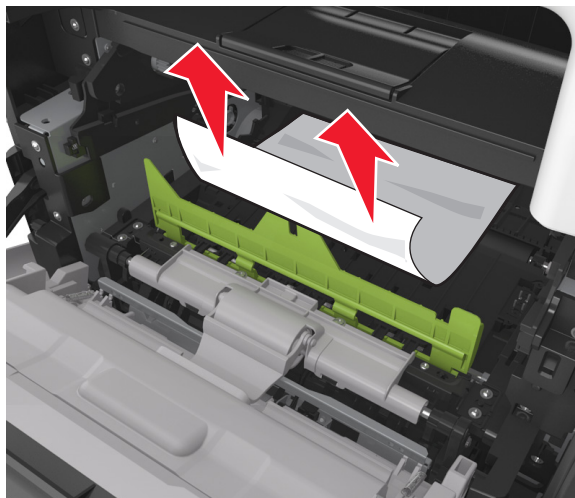

- 7 Insert the imaging unit by aligning the arrows on the side rails of the unit with the arrows on the side rails inside the printer, and then insert the imaging unit into the printer.

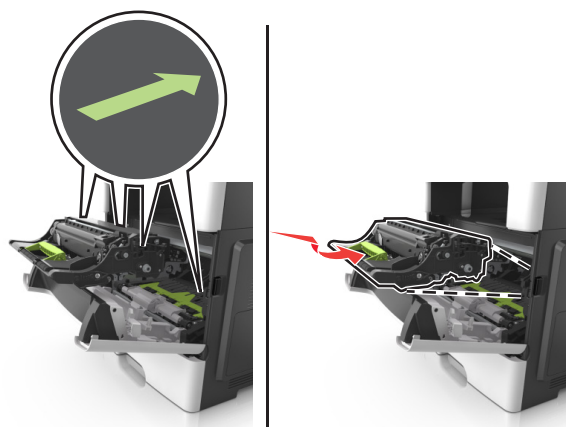

- 8 Insert the toner cartridge by aligning the side rails of the cartridge with the arrows on the side rails inside the printer, and then insert the cartridge into the printer.

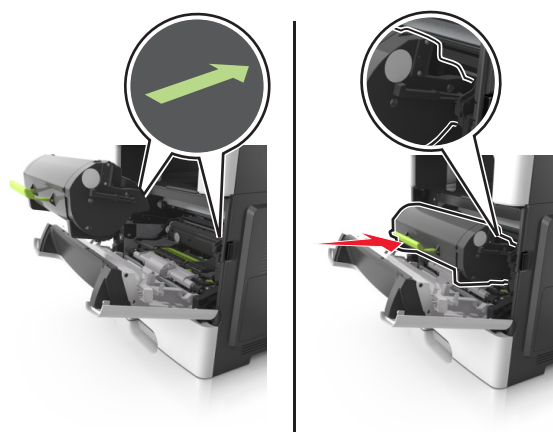

- 9 Close the front door.

- 10 From the printer control panel, select **Continue** to clear the message and continue printing.

200 paper jam messages

Notes:

- Some error messages are applicable only to printer models with installed polygon LSU (laser scanning unit).
- If the sixth digit character assigned to the serial number of the printer is in the P–Z range, then the printer is installed with a polygon LSU (example: 4514 2ZHH 007CR).

Error code	Description	Action
200.01	Input sensor covered during warm-up sequence.	Go to “Sensor (input) static jam service check” on page 97.
200.02	Input sensor covered too quickly.	Go to “Sensor (input) early/late arriving service check” on page 98.

Error code	Description	Action
200.03	Media did not reach input sensor from MPF.	Go to “Sensor (input) early/late arriving service check” on page 98.
200.05	Input sensor covered too long.	Go to “Sensor (input) early/late arriving service check” on page 98.
200.07	Input sensor failed to become uncovered from sheet ahead.	Go to “Sensor (input) early/late arriving service check” on page 98.
200.08	Page arrive at input sensor at unexpected time.	Go to “Sensor (input) early/late arriving service check” on page 98.
200.09	Printhead did not receive proper motor feedback to start laser servo.	Go to “Sensor (input) image jam service check” on page 99.
200.10	Printhead motor not locked when media reaches the input sensor.	Go to “Sensor (input) image jam service check” on page 99.
200.11	Printhead motor fell out of lock after page reaches the input sensor.	Go to “Sensor (input) image jam service check” on page 99.
	Mirror motor got locked, and then lost it again before the initial lock timeout.	Go to “Laser scanning unit (LSU) service check” on page 173.
200.12	Printhead was not ready for media.	Go to “Sensor (input) image jam service check” on page 99.
200.13	Media at input sensor is not the next media to be imaged.	Go to “Sensor (input) image jam service check” on page 99.
200.14	Media reached the input sensor before EP was ready.	Go to “Sensor (input) image jam service check” on page 99.
200.15	Image data did not start on time.	Go to “Sensor (input) image jam service check” on page 99.
200.16	Fuser motor stalled.	Go to “Main drive motor control jam service check” on page 100.
200.19	Page that was successfully picked from option tray never reached the input sensor.	Go to “Sensor (input) early/late arriving service check” on page 98.
200.21	No response from paper port driver while waiting for the source to deactivate the Input Source Ready flag to indicate it has initiated picking.	Go to “Sensor (input) early/late arriving service check” on page 98.
200.23	Laser servo never started due to potential conflict with the transfer servo.	Go to “Sensor (input) image jam service check” on page 99.
200.24	Measured gap at input sensor too small to meet video delivery requirements. (Not enough time since prior image finished to start new image).	Go to “Sensor (input) image jam service check” on page 99.
200.29	Printhead drive control out of range due to an external event beyond what the control is designed to handle.	Go to “Sensor (input) image jam service check” on page 99.
200.30	Invalid printhead NVRAM.	Go to “Sensor (input) image jam service check” on page 99.

Error code	Description	Action
200.31	Paper, in the middle of a job, at input sensor before interrupt occurred.	Go to “Sensor (input) early/late arriving service check” on page 98.
200.32	Detected cover switch bounce.	Go to “Sensor (input) early/late arriving service check” on page 98.
	Printhead lost HSYNCs due to a glitch with the laser safety interlock, for example, bouncy cover switch.	Go to “Laser scanning unit (LSU) service check” on page 173.
200.33	Input sensor covered too quickly.	Go to “Sensor (input) early/late arriving service check” on page 98.
200.38	Interpage servo gap smaller than expected for galvo offset target evaluation.	Go to “Sensor (input) early/late arriving service check” on page 98.
200.42	Rogue sheet at ACM sensor while flushing the paper path prior to declaring Tray 1 source empty.	Go to “Sensor (input) early/late arriving service check” on page 98.
200.44	Page from Tray 1 did not reach the input sensor (or the manual feed sensor, if present) after multiple pick attempts. Page did make it out of the tray at least as far as the ACM sensor.	Go to “Sensor (input) early/late arriving service check” on page 98.
200.45	During warm up flush, sheet detected too long over input sensor.	Go to “Sensor (input) early/late arriving service check” on page 98.

Sensor (input) static jam service check

Action	Yes	No
<p>Step 1</p> <p>Check the input sensor area for jammed media fragments.</p> <p>Is the paper path free of partially fed or jammed media?</p>	Go to step 2.	Clear the paper path of any media fragments.
<p>Step 2</p> <p>Check the jam access cover if it is blocking the input sensor.</p> <p>Is it blocking the input sensor?</p>	Replace the jam access cover. See “Jam access cover removal” on page 353.	Go to step 3.
<p>Step 3</p> <p>Check the input sensor cable for proper connection.</p> <p>Is it properly connected?</p>	Go to step 4.	Reseat the cable.
<p>Step 4</p> <p>POR into the Diagnostics menu and perform a sensor test: Diagnostics Menu > Base Sensor Test > Input.</p> <p>Does the sensor state on the control panel display change when it is toggled?</p>	Go to step 5.	Replace the input sensor. See “Duplex sensor and input sensor removal” on page 363.

Action	Yes	No
Step 5 Does the error remain?	Contact the next level of support.	The problem is solved.

Sensor (input) early/late arriving service check

Action	Yes	No
Step 1 Check the paper source. Is the paper from the MPF?	Go to step 2.	Go to step 5.
Step 2 Check the MPF pick roller and separator pad for damage and contamination. Are they free of damage and contamination?	Go to step 3.	Replace the MPF pick roller and separator pad. See “MPF pick roller removal” on page 352 and “Separator pad removal” on page 358 .
Step 3 Check the MPF solenoid for proper operation: <ul style="list-style-type: none"> a Remove the left cover. b POR into the Diagnostics menu and perform a feed test: Diagnostics Menu > Input Tray Tests > Feed Test > Multipurpose feeder c Check if the MPF solenoid moves when doing the feed test. Does it move when doing the feed test?	Go to step 4.	Replace the MPF solenoid. See “MPF solenoid removal” on page 306 .
Step 4 Make sure the MPF gearbox spring is properly installed and free of damage. Check the MPF gearbox for wear or damage. Are they free of wear or damage?	Go to step 5.	Replace the MPF gearbox. See “MPF gearbox removal” on page 308 .
Step 5 Check the input sensor area for jammed media fragments. Is the paper path free of partially fed or jammed media?	Go to step 6.	Clear the paper path of any media fragments.

Action	Yes	No
<p>Step 6</p> <p>Check the media present sensor and media present sensor flag for:</p> <ul style="list-style-type: none"> • Proper operation • Wear or damage <p>Do they properly operate, and are they free of wear or damage?</p>	Go to step 7.	Replace either the media present sensor or media present sensor flag, or both. See “Sensor (toner density) and media present sensor flag removal” on page 374.
<p>Step 7</p> <p>Check the jam access cover if it is blocking the input sensor.</p> <p>Is it blocking the input sensor?</p>	Replace the jam access cover. See “Jam access cover removal” on page 353.	Go to step 8.
<p>Step 8</p> <p>Check the input sensor cable for proper connection.</p> <p>Is it properly connected?</p>	Go to step 9.	Reseat the cable.
<p>Step 9</p> <p>POR into the Diagnostics menu and perform a sensor test: Diagnostics Menu > Base Sensor Test > Input</p> <p>Does the sensor state on the control panel display change when it is toggled?</p>	Go to step 10.	Replace the input sensor. See “Duplex sensor and input sensor removal” on page 363.
<p>Step 10</p> <p>Does the error remain?</p>	Contact the next level of support.	The problem is solved.

Sensor (input) image jam service check

Action	Yes	No
<p>Step 1</p> <p>Check the LSU cables for proper connection.</p> <p>Are they properly connected?</p>	Go to step 2.	Reseat the cables.
<p>Step 2</p> <p>Inspect the LSU cables and connectors.</p> <p>Are they free of damage?</p>	Go to step 3.	Replace the LSU. See “Laser scanning unit (LSU) removal” on page 395.
<p>Step 3</p> <p>Check the input sensor cable for proper connection.</p> <p>Is it properly connected?</p>	Go to step 4.	Reseat the cable.

Action	Yes	No
<p>Step 4 POR into the Diagnostics menu and perform a feed test: Diagnostics Menu > Input Tray Tests > Feed Tests > Tray 1</p> <p>Does it pass the test?</p>	Go to step 5.	Replace the LSU. See “Laser scanning unit (LSU) removal” on page 395.
<p>Step 5 POR into the Diagnostics menu and perform a sensor test: Diagnostics Menu > Base Sensor Test > Input</p> <p>Does the sensor state on the control panel display change when it is toggled?</p>	Go to step 6.	Replace the input sensor. See “Duplex sensor and input sensor removal” on page 363.
<p>Step 6 Check the controller board for any damage.</p> <p>Is it free of damage?</p>	Go to step 7.	Replace the controller board. See “Controller board removal” on page 320.
<p>Step 7 Does the error remain?</p>	Contact the next level of support.	The problem is solved.

Main drive motor control jam service check

Action	Yes	No
<p>Step 1 a Remove the main drive gearbox. b Check the main drive gearbox cable for proper connection.</p> <p>Is it properly connected?</p>	Go to step 2.	Reseat the cable.
<p>Step 2 a Remove the main drive gearbox. b Check the gears of main drive gearbox for wear or damage.</p> <p>Are they free of wear or damage?</p>	Go to step 3.	Replace the main drive gearbox. See “Main drive gearbox removal” on page 304.
<p>Step 3 Check the main drive motor for proper operation: a Remove the main drive gearbox. Note: Do not disconnect the main drive gearbox cable. b POR into the Diagnostics menu and perform a feed test: Diagnostics menu > Input Tray Tests > Feed Test > Select any input source c Check if the main drive motor rotates when doing the feed test.</p> <p>Does it rotate when doing the feed test?</p>	Go to step 4.	Replace the main drive gearbox. See “Main drive gearbox removal” on page 304.

Action	Yes	No
<p>Step 4 Check the fuser gear for damage or toner contamination.</p> <p>Is it free of damage and contamination?</p>	<p>Replace the controller board. See “Controller board removal” on page 320.</p>	<p>Replace the fuser. See “Fuser removal” on page 386.</p>

201 paper jams

201 paper jam messages

Error code	Description	Action
201.01	Narrow media sensor is covered during warm up. Input sensor is not covered.	Go to “Sensor (narrow media) jam service check” on page 101.
201.20	Took too long to ramp up auger motor.	Go to “Cartridge gearbox service check” on page 181.
201.21	Stopped detecting pulses from auger motor's encoder system.	Go to “Cartridge gearbox service check” on page 181.
201.22	Auger motor underspeed error.	Go to “Cartridge gearbox service check” on page 181.

Sensor (narrow media) jam service check

Action	Yes	No
<p>Step 1 Check the narrow media sensor for jammed media fragments.</p> <p>Is the paper path free of partially fed or jammed media?</p>	Go to step 2.	Clear the paper path of any media fragments.
<p>Step 2 Check the narrow media sensor cable JNRW1 for proper connection.</p> <p>Is it properly connected?</p>	Go to step 3.	Reseat the cable.
<p>Step 3 POR into the Diagnostics menu and perform a sensor test: Diagnostics Menu > Base Sensor Test > Narrow Media</p> <p>Does the sensor state on the control panel display change when it is toggled?</p>	Go to step 4.	Replace the narrow media sensor.
<p>Step 4 Does the error remain?</p>	Contact the next level of support.	The problem is solved.

202 paper jams

[x]-page jam, open rear door. [20y.xx]

- 1 Open the front door to loosen the jammed paper in the rear door.

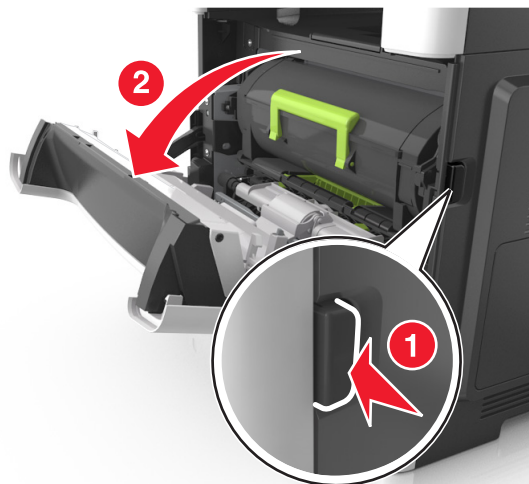

- 2 Gently pull down the rear door.

 **CAUTION—HOT SURFACE:** The inside of the printer might be hot. To reduce the risk of injury from a hot component, allow the surface to cool before touching it.

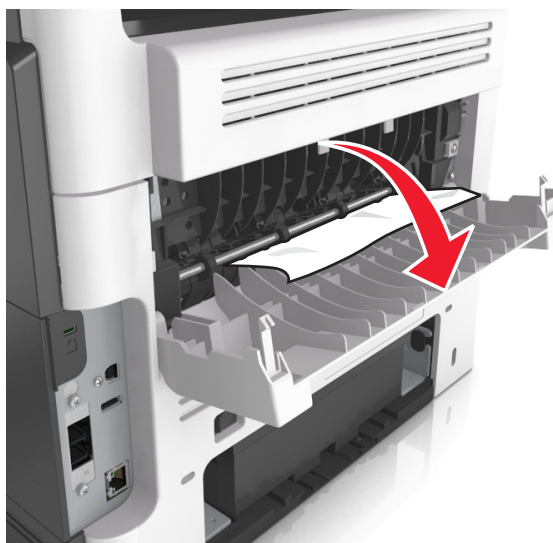

- 3 Firmly grasp the jammed paper on each side, and then gently pull it out.

Note: Make sure all paper fragments are removed.

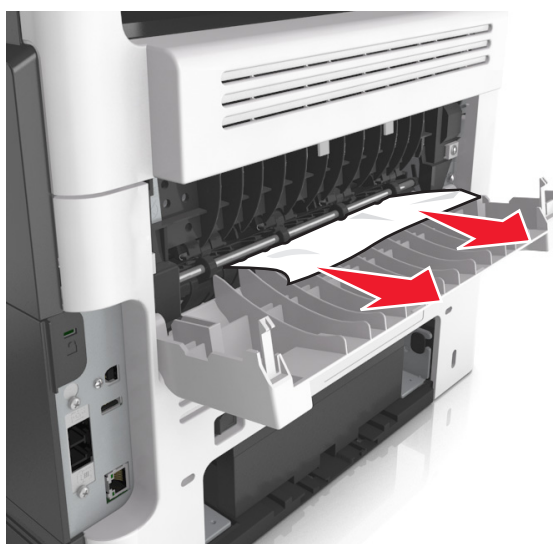

4 Close the front and rear door.

5 From the printer control panel, select **Done** to clear the message and continue printing.

202 paper jam messages

Error code	Description	Action
202.01	Exit sensor is covered during warm up.	Go to “Sensor (fuser exit) jam service check” on page 104.
202.03	Media did not reach the fuser exit sensor.	Go to “Sensor (fuser exit) jam service check” on page 104.
202.05	Fuser exit sensor covered too long by the current sheet.	Go to “Sensor (fuser exit) jam service check” on page 104.
202.07	Fuser exit sensor covered too long by the previous sheet.	Go to “Sensor (fuser exit) jam service check” on page 104.
202.13	Restart attempted after an internal jam without cover open. Close event. Likely that the jam was not actually cleared.	Go to “Sensor (fuser exit) jam service check” on page 104.
202.14	Expected banner sheet (assumed wide) not detected by narrow media sensor, possible accordion jam, unsupported narrow banner media, or missing signal.	Go to “Sensor (fuser exit) jam service check” on page 104.
202.16	Page at fuser nip before fuser started ramping toward desired. Indicates code may be receiving more hall interrupts than intended.	Go to “Sensor (fuser exit) jam service check” on page 104.
202.17	Page at fuser nip before fuser reached acceptable operating temperature. Page arrived at fuser earlier than expected, so it was probably staged.	Go to “Sensor (fuser exit) jam service check” on page 104.
202.22	Cartridge Motor - Motor Underspeed Error. Motor made it to closed loop steady state, but then detected speed was below threshold.	Go to “Sensor (fuser exit) jam service check” on page 104.

Error code	Description	Action
202.28	Exit sensor bounce issue.	Go to “Sensor (fuser exit) jam service check” on page 104.
202.32	The sheet is too long to be duplexed. The blow through is enabled.	Go to “Duplex service check” on page 107.
202.36	Long paper or shingled multi feed stopped before sending to duplex.	Go to “Duplex service check” on page 107.
202.43	During warm up flush, media that passed the input sensor failed to reach the exit sensor.	Go to “Sensor (fuser exit) jam service check” on page 104.
202.45	During warm up flush, sheet detected too long over exit sensor.	Go to “Sensor (fuser exit) jam service check” on page 104.

Sensor (fuser exit) jam service check

Action	Yes	No
<p>Step 1 Check the input sensor area for jammed media fragments.</p> <p>Is the paper path free of partially fed or jammed media?</p>	Go to step 2.	Clear the paper path of any media fragments.
<p>Step 2 Check the fuser exit sensor cable JEXIT1 for proper connection.</p> <p>Is it properly connected?</p>	Go to step 3.	Reseat the cable.
<p>Step 3 POR into the Diagnostics menu and perform a sensor test: Diagnostics Menu > Base Sensor Test > Exit</p> <p>Does the sensor state on the control panel display change when it is toggled?</p>	Go to step 4.	Replace the fuser. See “Fuser removal” on page 386.
<p>Step 4 Check the fuser gears and rollers for damage.</p> <p>Are they free of damage?</p>	Go to step 5.	Replace the fuser. See “Fuser removal” on page 386.
<p>Step 5 Does the error remain?</p>	Contact the next level of support.	The problem is solved.

23y paper jams

[x]-page jam, remove tray 1 to clear duplex. [23y.xx]

- 1 Pull out the tray completely.

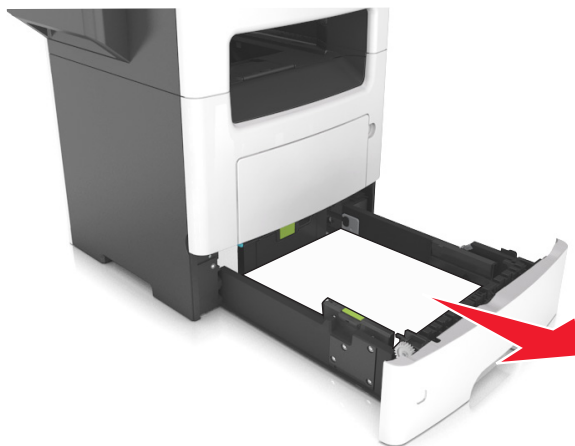

- 2 Locate the lever, and then pull it down to release the jam.

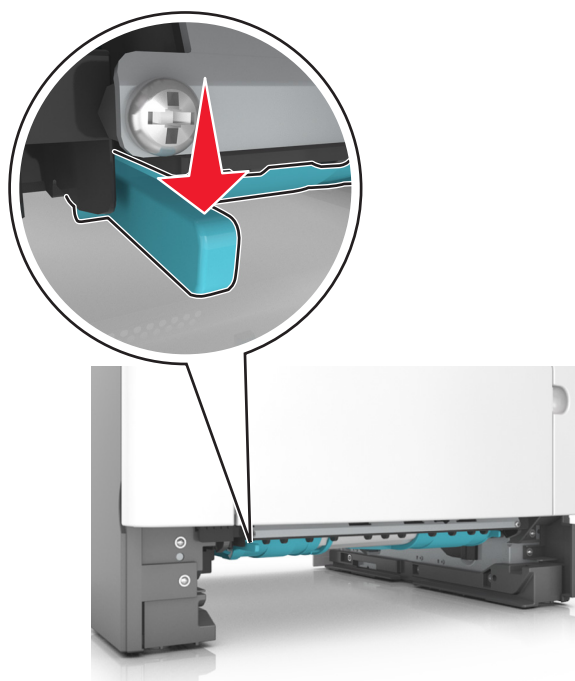

- 3 Firmly grasp the jammed paper on each side, and then gently pull it out.

Note: Make sure all paper fragments are removed.

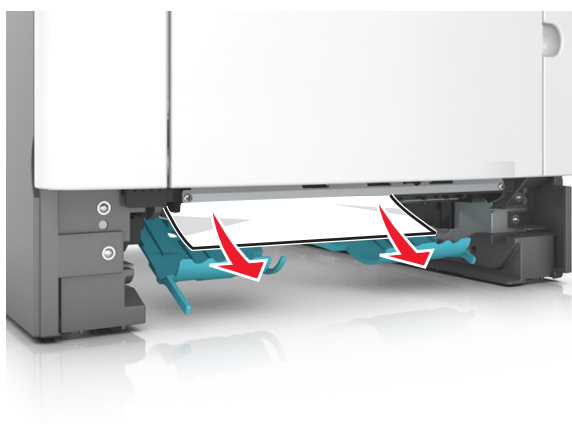

4 Insert the tray.

5 From the printer control panel, touch **Done** to clear the message and continue printing.

23y paper jam messages

Error code	Description	Action
230.01	Sheet covering internal duplex sensor during warm up.	Go to “Duplex service check” on page 107.
230.02	Paper jam around internal duplex.	Go to “Duplex service check” on page 107.
230.03	Internal duplex sensor never made by leading edge of page.	Go to “Duplex service check” on page 107.
230.04	Page in duplexer ahead of current reversing page never staged.	Go to “Duplex service check” on page 107.
230.05	Internal duplex sensor never broke on the trailing edge of the sheet.	Go to “Duplex service check” on page 107.
230.07	Internal duplex sensor never broke from sheet ahead of page.	Go to “Duplex service check” on page 107.
230.09	Page in duplexer never picked.	Go to “Duplex service check” on page 107.
230.10	Narrow page reversing into duplexer.	Go to “Duplex service check” on page 107.
230.28	Bouncy duplex sensor never made.	Go to “Duplex service check” on page 107.
232.03	Input sensor never detected sheet from internal duplex path.	Go to “Duplex service check” on page 107.
232.10	Feed error picking from the duplexer.	Go to “Duplex service check” on page 107.

Duplex service check

Action	Yes	No
<p>Step 1</p> <p>a Remove the rear cover.</p> <p>b Check the redrive rollers for wear or damage.</p> <p>Are they free of wear or damage?</p>	Go to step 2.	Replace the redrive assembly. See “Redrive assembly removal” on page 383.
<p>Step 2</p> <p>a Remove the left cover. See “Left cover removal” on page 302.</p> <p>b POR into the Diagnostics menu and navigate to: DUPLEX TESTS > Duplex Feed 1</p> <p>c Check the reverse solenoid for proper operation.</p> <p>Does it function properly?</p>	Go to step 3.	Replace the reverse solenoid. See “Reverse solenoid removal” on page 311.
<p>Step 3</p> <p>a Remove the input tray.</p> <p>b From under the printer, check the duplex gear assembly and duplex link for wear and damage.</p> <p>Are the they free of wear and damage?</p>	Go to step 4.	Replace the duplex gear assembly. See “Duplex gear assembly removal” on page 313.
<p>Step 4</p> <p>From under the printer, check the duplex, belt, and roller for wear and damage.</p> <p>Are they free of wear and damage?</p>	Go to step 5.	Replace the duplex. See “Duplex removal” on page 362.
<p>Step 5</p> <p>a POR into the Diagnostics menu and navigate to: DUPLEX TESTS > Sensor Test</p> <p>b Lower the jam access cover, and toggle the duplex sensor.</p> <p>Does the sensor state on the control panel change when it is toggled?</p>	Go to step 6.	Replace the duplex sensor. See “Duplex sensor and input sensor removal” on page 363.
<p>Step 6</p> <p>Does the error remain?</p>	Contact the next level of support.	The problem is solved.

241 paper jams

[x]-page jam, open tray [1]. [241.xx]

- 1 Pull out the tray completely.

Note: The message on the printer display indicates the tray where the jammed paper is located.

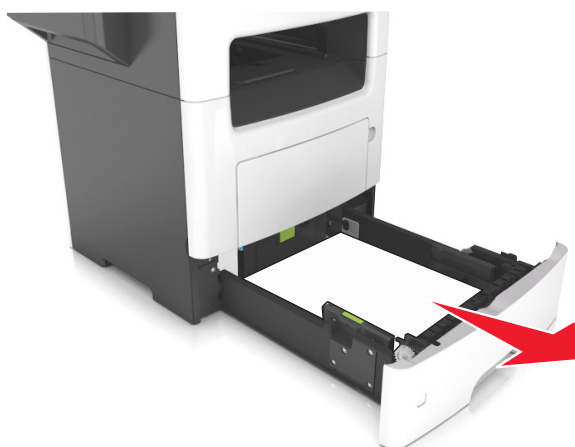

2 Firmly grasp the jammed paper on each side, and then gently pull it out.

Note: Make sure all paper fragments are removed.

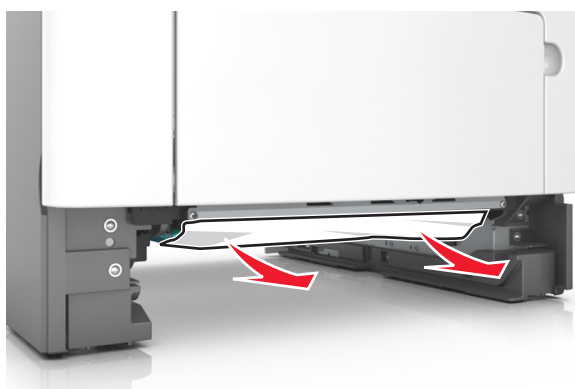

3 Insert the tray.

4 From the printer control panel, touch **Done** to clear the message and continue printing.

241 paper jam messages

Error code	Description	Action
241.01	Paper over tray 1 pass thru sensor on warmup.	Go to “Tray 1 jam service check” on page 110.
241.02	Sensor (input) early arriving jam.	
241.03	Tray 1 pass thru sensor never became covered when feeding a sheet from an option below.	
241.06	Failed to pick from tray 1. Exhausted all pick retries. Paper present sensing indicated media is in the tray.	Go to “24x.06 service check” on page 112.

Error code	Description	Action
241.07	Option tray 1 pass thru sensor never became uncovered when feeding a sheet from an option below.	Go to “Tray 1 jam service check” on page 110.
241.13	The media is late reaching the sensor (input) within the specified time from tray 1.	
241.14	The media is late reaching the sensor (input) within the specified time from tray 1.	
241.15	Media tray 1, tray pulled jam.	
241.16	The engine timed out waiting for the tray 1 to report 'ready' before the 1st pick attempt.	
241.17	Page was not properly picked from tray 1. Have not exhausted all pick retry attempts as there are sheets committed to the paper path from below.	
241.18	Failed to feed from tray 1. Exhausted all pick retries. Paper present sensing indicates media is in the tray.	
241.20	Took too long to ramp up media feeder motor in tray 1.	Go to “Tray 1 jam service check” on page 110.
241.21	Media feeder motor stall in tray 1.	
241.22	Media feeder motor pick motor underspeed in tray 1.	
241.24	Media feeder motor stalled on the last pick attempt in tray 1.	
241.29	Tray 1 lift plate failed to make the index sensor while elevating.	
241.32	Media tray not ready.	
241.33	The media tray was pulled during the media pick process.	

Error code	Description	Action
241.41	Media feeder motor stall in tray 1.	Go to “Tray 1 jam service check” on page 110.
241.42	Media feeder motor pick motor under-speed in tray 1.	
241.43	Media feeder motor stalled on the last pick attempt in tray 1.	
241.44	Motor 2 (Separator/Passthru) motor stalled.	
241.45	Motor 2 (Separator/Passthru) motor PWM overflow error (underspeed). Motor underspeed (max PWM and motor underspeed, typical accordion jam).	
241.46	Motor 2 (Separator/Passthru) motor ramp (end ramp - did not reach speed, typical pack feed paper jam).	
241.47	Motor 3 motor stalled.	
241.48	Motor 3 motor PWM overflow error (underspeed). Motor underspeed (max PWM and motor underspeed, typical accordion jam).	
241.49	Motor 3 motor ramp (end ramp - did not reach speed, typical pack feed paper jam).	

Tray 1 jam service check

Action	Yes	No
<p>Step 1 Restart the printer.</p> <p>Does it fail to complete the POST sequence and display a 241.xx error?</p>	Replace the index sensor.	Go to step 2.
<p>Step 2 Check the pick tires.</p> <p>Are they free of wear or damage?</p>	Go to step 3.	Replace the pick tires.
<p>Step 3 Check the separator roll assembly.</p> <p>Is it free of wear or damage?</p>	Go to step 4.	Replace the separator roll assembly. See “Separator roll assembly removal” on page 416.
<p>Step 4 Check the tray guides and lift plate gear.</p> <p>Are they free of wear or damage?</p>	Go to step 5.	Replace the tray insert.

Action	Yes	No
<p>Step 5 Check the front input guide. Is it free of damage?</p>	Go to step 6.	Replace the front input guide. See “Front input guide removal” on page 356.
<p>Step 6 a POR into the Diagnostics menu and perform a feed test: Diagnostics Menu > Input Tray Tests > Feed Test > Tray 1 > Continuous b Cancel the test after five pages. Does the printer successfully feed the five pages into the output bin?</p>	Go to step 8.	Go to step 7.
<p>Step 7 Observe the location of the jammed paper. Are the first page fed to the output bin, the second page jammed in the rear door, and the third page jammed in the input tray?</p>	Go to step 8.	Replace the trailing edge sensor. See “Trailing edge sensor removal” on page 368.
<p>Step 8 Perform a tray 1 pick/lift motor gearbox service check. See “Tray 1 pick/lift motor gearbox service check” on page 180. Does the error remain?</p>	Go to step 9.	The problem is solved.
<p>Step 9 Check the ACM assembly. Is it free of wear or damage?</p>	Go to step 10.	Replace the ACM assembly. See “ACM assembly removal” on page 369.
<p>Step 10 Check the MPF gearbox. Is it free of wear or damage?</p>	Go to step 11.	Replace the MPF gearbox. See “MPF gearbox removal” on page 308.
<p>Step 11 Check the main drive gearbox. Is it free of wear or damage?</p>	Go to step 12.	Replace the main drive gearbox. See “Main drive gearbox removal” on page 304.
<p>Step 12 a Make sure that the media present sensor and flag are properly installed. b Check the sensor and flag. Are they free of damage?</p>	Go to step 13.	Replace the media present sensor or flag. See “Sensor (toner density) and media present sensor flag removal” on page 374.

Action	Yes	No
Step 13 Does the error remain?	Contact the next level of support.	The problem is solved.

24x.06 service check

Action	Yes	No
Step 1 Check the paper for damage, moisture, or waviness. Replace with new paper if necessary. Does the problem remain?	Go to step 2.	The problem is solved.
Step 2 Make sure that the paper tray guides are properly set, and adjust if necessary. Does the problem remain?	Go to step 3.	The problem is solved.
Step 3 Check the pick tires for debris or wear, and replace if necessary. Does the problem remain?	Go to step 4.	The problem is solved.
Step 4 Check the media present flag for damage, and replace if necessary. Does the problem remain?	Go to step 5.	The problem is solved.
Step 5 Check the ACM cable at the JACM1 connector on the controller board for proper connection. Does the problem remain?	See “Tray 1 jam service check” on page 110.	The problem is solved.

242–244 paper jams

[x]-page jam, open tray [x]. [24y.xx]

- 1 Pull out the tray completely.

Note: The message on the printer display indicates the tray where the jammed paper is located.

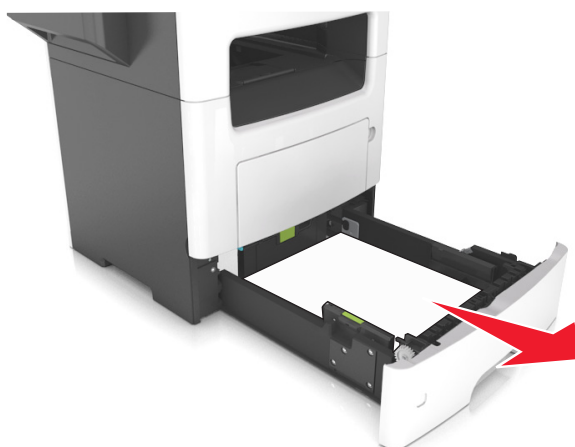

2 Firmly grasp the jammed paper on each side, and then gently pull it out.

Note: Make sure all paper fragments are removed.

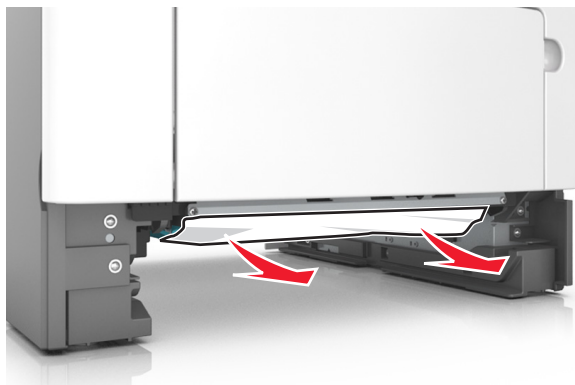

3 Insert the tray.

4 From the printer control panel, touch **Done** to clear the message and continue printing.

242 paper jam messages

Error code	Description	Action
242.01	Paper over tray 2 pass through sensor on warm-up.	Go to “Option tray jam service check” on page 120.
242.02	Input sensor detected late feed during a pick retry from tray 2.	
242.03	Tray 2 pass through sensor never became covered when feeding a sheet from an option below.	
242.06	Failed to feed from tray. Paper present sensing supported and indicates media still in tray.	
242.07	Option tray 2 pass through sensor never became uncovered when feeding a sheet from an option below.	
242.09	Tray 2 pick motor lost encoder.	
242.11	ACM Pick/Lift Motor—Encoder Never Detected in tray 2.	
242.12	Motor ramp up error in tray 2.	
242.13	Page to be stapled failed to feed from tray.	
242.14	Sheets flushed from paper path either due to feed error or cartridge error.	
242.15	One or more trays located above the source tray 2 has been pulled.	
242.16	The engine timed out waiting for the tray 2 to report ready before the 1st pick attempt.	
242.17	Page was not properly picked from tray 2. Have not exhausted all pick retry attempts as there are sheets committed to the paper path from below.	
242.19	Tray 2 fail to feed error. Detected while trying to pick a sheet, and that leading edge was not detected by tray sensor.	

Error code	Description	Action
242.20	Took too long to ramp up dc feed motor in tray 2.	Go to “Option tray jam service check” on page 120.
242.21	Pick motor stall in tray 2.	
242.22	Tray 2 pick motor underspeed.	
242.24	DC Feed ACM stalled on the last pick attempt in tray 2.	
242.32	Tray not ready.	
242.33	Pick received but detected a tray pulled.	
242.41	Motor 1 (Pick/Lift) Elevator motor stalled.	
242.42	Motor 1 (Pick/Lift) Elevator motor PWM overflow error (underspeed). Motor underspeed (max PWM and motor underspeed, typical accordion jam).	
242.43	Motor 1 (Pick/Lift) motor ramp (end ramp - did not reach speed, typical pack feed paper jam).	
242.44	Motor 2 (Separator/Pass through) motor stalled.	
242.45	Motor 2 (Separator/Pass through) motor PWM overflow error (underspeed). Motor underspeed (max PWM and motor underspeed, typical accordion jam).	
242.46	Motor 2 (Separator/Pass through) motor ramp (end ramp - did not reach speed, typical pack feed paper jam).	
242.47	Motor 3 motor stalled.	
242.48	Motor 3 motor PWM overflow error (underspeed). Motor underspeed (max PWM and motor underspeed, typical accordion jam).	
242.49	Motor 3 motor ramp (end ramp - did not reach speed, typical pack feed paper jam).	

243 paper jam messages

Error code	Description	Action
243.01	Paper over tray 3 pass through sensor on warm-up.	Go to “Option tray jam service check” on page 120.
243.02	Input sensor detected late feed during a pick retry from tray 3.	
243.03	tray 3 pass through sensor never became covered when feeding a sheet from an option below.	
243.06	Failed to feed from tray. Paper present sensing supported and indicates media still in tray.	
243.07	Option tray 3 pass through sensor never became uncovered when feeding a sheet from an option below.	
243.09	Tray 3 pick motor lost encoder.	
243.10	Failed to feed from tray.	
243.11	ACM pick/lift motor encoder never detected in tray 3.	
243.12	Motor ramp up error in tray 3.	
243.13	Page to be stapled failed to feed from tray.	
243.14	Sheets flushed from paper path either due to feed error or cartridge error.	
243.15	One or more trays located above the source tray 3 has been pulled.	
243.16	The engine timed out waiting for the tray 3 to report 'ready' before the 1st pick attempt.	
243.17	Page was not properly picked from tray 3. Have not exhausted all pick retry attempts as there are sheets committed to the paper path from below.	
243.19	Tray 3 fail to feed error. Detected while trying to pick a sheet, and that leading edge was not detected by tray sensor.	

Error code	Description	Action
243.20	Took too long to ramp up dc feed motor in tray 3.	Go to “Option tray jam service check” on page 120.
243.21	Pick motor stall in tray 3.	
243.22	Tray 3 pick motor underspeed.	
243.24	DC Feed ACM stalled on the last pick attempt in tray 3.	
243.32	Tray not ready.	
243.33	Pick received but detected a tray pulled.	
243.41	Motor 1 (Pick/Lift) Elevator motor stalled.	
243.42	Motor 1 (Pick/Lift) Elevator motor PWM overflow error (underspeed). Motor underspeed (max PWM and motor underspeed, typical accordion jam).	
243.43	Motor 1 (Pick/Lift) motor ramp (end ramp - did not reach speed, typical pack feed paper jam).	
243.44	Motor 2 (Separator/Pass through) motor stalled.	
243.45	Motor 2 (Separator/Pass through) motor PWM overflow error (underspeed). Motor underspeed (max PWM and motor underspeed, typical accordion jam).	
243.46	Motor 2 (Separator/Pass through) motor ramp (end ramp - did not reach speed, typical pack feed paper jam).	
243.47	Motor 3 motor stalled.	
243.48	Motor 3 motor PWM overflow error (underspeed). Motor underspeed (max PWM and motor underspeed, typical accordion jam).	
243.49	Motor 3 motor ramp (end ramp - did not reach speed, typical pack feed paper jam).	

244 paper jam messages

Error code	Description	Action
244.01	Paper over tray 4 pass through sensor on warm-up.	Go to “Option tray jam service check” on page 120.
244.02	Input sensor detected late feed during a pick retry from tray 4.	
244.03	Tray 4 pass through sensor never became covered when feeding a sheet from an option below.	
244.06	Failed to feed from tray. Paper present sensing supported and indicates media still in tray.	
244.07	Option tray 4 pass through sensor never became uncovered when feeding a sheet from an option below.	
244.09	Tray 4 pick motor lost encoder.	
244.11	ACM Pick / Lift Motor - Encoder Never Detected in tray 4.	
244.12	Motor ramp up error in tray 4.	
244.13	Page to be stapled failed to feed from tray.	
244.14	Sheets flushed from paper path either due to feed error or cartridge error.	
244.15	One or more trays located above the source tray 4 has been pulled.	
244.16	The engine timed out waiting for the tray 4 to report 'ready' before the 1st pick attempt.	
244.17	Page was not properly picked from tray 4. Have not exhausted all pick retry attempts as there are sheets committed to the paper path from below.	
244.19	Tray 4 fail to feed error. Detected while trying to pick a sheet, and that leading edge was not detected by tray sensor.	

Error code	Description	Action
244.20	Took too long to ramp up dc feed motor in tray 4.	Go to “Option tray jam service check” on page 120.
244.21	Pick motor stall in tray 4.	
244.22	Tray 4 pick motor underspeed.	
244.24	DC Feed ACM stalled on the last pick attempt in tray 4.	
244.32	Tray not ready.	
244.33	Pick received but detected a tray pulled.	
244.41	Motor 1 (Pick/Lift) Elevator motor stalled.	
244.42	Motor 1 (Pick/Lift) Elevator motor PWM overflow error (underspeed). Motor underspeed (max PWM and motor underspeed, typical accordion jam).	
244.43	Motor 1 (Pick/Lift) motor ramp (end ramp - did not reach speed, typical pack feed paper jam).	
244.44	Motor 2 (Separator/Pass through) motor stalled.	
244.45	Motor 2 (Separator/Pass through) motor PWM overflow error (underspeed). Motor underspeed (max PWM and motor underspeed, typical accordion jam).	
244.46	Motor 2 (Separator/Pass through) motor ramp (end ramp - did not reach speed, typical pack feed paper jam).	
244.47	Motor 3 motor stalled.	
244.48	Motor 3 motor PWM overflow error (underspeed). Motor underspeed (max PWM and motor underspeed, typical accordion jam).	
244.49	Motor 3 motor ramp (end ramp - did not reach speed, typical pack feed paper jam).	

Option tray jam service check

Action	Yes	No
<p>Step 1 Restart the printer.</p> <p>Does it fail to complete the POST sequence and display a 242.01 error?</p>	Replace the option tray.	Go to step 2.
<p>Step 2 a POR into the Diagnostics menu and perform a feed test: Diagnostics Menu > Input Tray Tests > Feed Test > Select an option tray > Continuous b Cancel the test after five pages.</p> <p>Does the printer successfully feed the five pages into the output bin?</p>	The problem is solved.	Go to step 3.
<p>Step 3 Does the printer display a 242.06 error?</p>	Replace the ACM assembly. See “ACM assembly removal” on page 418.	Go to step 4.
<p>Step 4 Check the pick roller assembly.</p> <p>Is it free of wear or damage?</p>	Go to step 5.	Replace the pick roller assembly. See “Pick roller removal” on page 415.
<p>Step 5 Check the separator roll assembly.</p> <p>Is it free of wear or damage?</p>	Go to step 6.	Replace the separator roll assembly. See “Separator roll assembly removal” on page 416.
<p>Step 6 Check the tray guides, lift plate, and lift plate gears.</p> <p>Are they free of wear or damage?</p>	Go to step 7.	Replace the tray insert.
<p>Step 7 Check the ACM assembly.</p> <p>Is it free of wear or damage?</p>	Go to step 8.	Replace the ACM assembly. See “ACM assembly removal” on page 418.
<p>Step 8 POR into the Diagnostics menu and perform a feed test: Diagnostics Menu > Input Tray Tests > Feed Test > Select an option tray</p> <p>Does the pick/lift motor gearbox pass the test?</p>	Go to step 9.	Replace the option tray.

Action	Yes	No
Step 9 Does the error remain?	Contact the next level of support.	The problem is solved.

25y paper jams

[x]-page jam, clear manual feeder. [25y.xx]

- 1 From the multipurpose feeder, firmly grasp the jammed paper on each side, and then gently pull it out.

Note: Make sure all paper fragments are removed.



- 2 Flex the sheets back and forth to loosen them, and then fan them. Do not fold or crease the paper. Straighten the edges on a level surface.

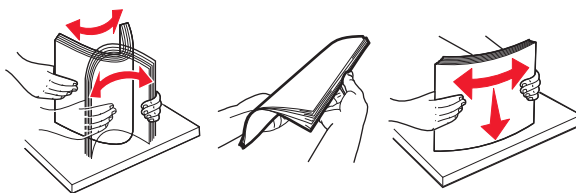

- 3 Reload paper into the multipurpose feeder.



Note: Make sure the paper guide lightly rests against the edge of the paper.

- 4 From the printer control panel, touch **Done** to clear the message and continue printing.

25y paper jam messages

Error code	Description	Action
250.06	Input sensor did not detect sheet picked from MPF. No other sheets should be in the path.	Go to “MPF service check” on page 123.
250.10	Input sensor did not detect sheet picked from MPF. No other sheets should be in the path.	Go to “MPF service check” on page 123.
250.13	Input sensor did not detect sheet picked from MPF. Sheet also last page of stapled job.	Go to “MPF service check” on page 123.
250.14	Input sensor did not detect sheet picked from MPF. Other sheets should have been flushed.	Go to “MPF service check” on page 123.
250.17	Input sensor did not detect sheet picked from MPF. No other sheets should be in the path.	Go to “MPF service check” on page 123.
250.18	Input sensor did not detect sheet picked from MPF. Other sheets could be in the path.	Go to “MPF service check” on page 123.

MPF service check

Action	Yes	No
<p>Step 1</p> <p>Check the springs, links, and tray guides on the MPF assembly for damage.</p> <p>Are they free of damage?</p>	Go to step 2.	Replace the MPF assembly. See “MPF tray removal” on page 349.
<p>Step 2</p> <p>a Make sure the MPF sensor cable is properly connected to the controller board.</p> <p>b POR into the Diagnostics menu and perform a sensor test: Diagnostics Menu > Input Tray Tests > Sensor Tests > Multi-Purpose Feeder</p> <p>Does the sensor state on the control panel display change when it is toggled?</p>	Go to step 3.	Replace the front input guide. See “Front input guide removal” on page 356.
<p>Step 3</p> <p>Make sure the MPF pick roller and separator pad are free of debris. Check both for wear or damage.</p> <p>Are they free of damage?</p>	Go to step 4.	Replace the MPF pick roller and separator pad. See “MPF pick roller removal” on page 352 and “Separator pad removal” on page 358.
<p>Step 4</p> <p>a Remove the left cover.</p> <p>b POR into the Diagnostics menu and perform a feed test: Diagnostics Menu > Input Tray Tests > Feed Tests > Multi-Purpose Feeder</p> <p>c Check the MPF solenoid for proper operation.</p> <p>Does it function properly?</p>	Go to step 5.	Replace the MPF solenoid. See “MPF solenoid removal” on page 306.
<p>Step 5</p> <p>a Make sure the MPF gearbox is free of debris.</p> <p>b Check the gears and spring of the MPF gearbox for wear or damage.</p> <p>Are they free of damage?</p>	Go to step 6.	Replace the MPF gearbox. See “MPF gearbox removal” on page 308.
<p>Step 6</p> <p>Does the error remain?</p>	Contact the next level of support.	The problem is solved.

28y paper jams

[x]-page jam, open automatic feeder top cover. [28y.xx]

- 1 Remove all original documents from the ADF tray.

Note: The message is cleared when the pages are removed from the ADF tray.

- 2 Open the ADF cover.

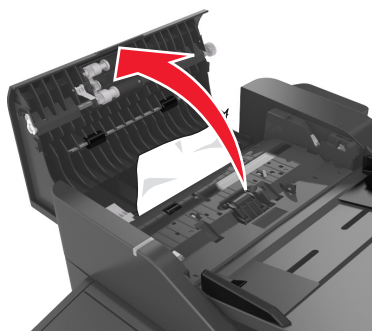

- 3 Firmly grasp the jammed paper on each side, and then gently pull it out.

Note: Make sure all paper fragments are removed.

- 4 Close the ADF cover.

- 5 Straighten the edges of the original documents, then load the documents into the ADF, and then adjust the paper guide.

- 6 From the printer control panel, touch **Done** to clear the message and continue printing.

28y paper jam messages

Error code	Description	Action
280.06	Paper missing—posted when paper is removed from input tray after job is initiated.	Go to “ADF paper jam service check” on page 125.
282.01	ADF static jam—interval sensor active at POR time.	
282.03	ADF pickup jam—LE of paper does not reach interval sensor in time.	
282.05	ADF long page—TE never clears interval sensor (but 1st scan sensor and exit sensor are both active).	
283.01	ADF static jam—1st scan sensor active at POR time.	
283.03	ADF feed jam—LE of paper does not reach 1st scan sensor in time.	
283.05	1st scan sensor jam—TE never clears 1st scan sensor.	
286.02	ADF back feed—page(s) in the exit area accidentally gets pulled into the reverse path.	Too many sheets of paper in the ADF exit bin. Remove the sheets from the ADF exit bin.
286.03	ADF backside feed jam—LE does not reach the multipurpose interval sensor in time when page routed through reverse area.	Go to “ADF paper jam service check” on page 125.
286.05	ADF backside jam—TE does not reach the multipurpose interval sensor in time when page routed through reverse area.	

ADF paper jam service check

Notes:

- Before performing this check, update the scanner firmware. For more information on the correct firmware version, contact the next level of support.
- This service check should be used if the paper feeds and jams in the ADF. If the paper is not feeding into the ADF, then see [“ADF feed errors service check” on page 205.](#)

Actions	Yes	No
<p>Step 1 Check the paper for damage such as wrinkles, moisture or tears.</p> <p>Is the paper damaged?</p>	Go to step 2.	Go to step 3.
<p>Step 2 Send a scan job using an undamaged paper.</p> <p>Does the problem remain?</p>	Go to step 3.	The problem is solved.
<p>Step 3 Run another scan job.</p> <p>Is the paper skewing when it is fed into the ADF?</p>	Go to step 4.	Go to step 5.
<p>Step 4</p> <ul style="list-style-type: none"> a Check the ADF guides for proper adjustment. b Check if the ADF top cover is properly closed. c Run a scan job. <p>Does the problem remain?</p>	Go to step 5.	The problem is solved.
<p>Step 5 Check the ADF rollers for dirt, debris, contamination or wear.</p> <p>Are the rollers contaminated or worn?</p>	Go to step 6.	Go to step 7.
<p>Step 6 Replace the separator roller and ADF top cover. See “ADF separator roll removal” on page 399 and “ADF top cover assembly removal” on page 407.</p> <p>Does the problem remain?</p>	Go to step 7.	The problem is solved.
<p>Step 7 Check the paper path for paper fragments and debris.</p> <p>Is the paper path free from obstructions?</p>	Go to step 9.	Go to step 8.
<p>Step 8 Clear the paper path of debris or obstructions.</p> <p>Does the problem remain?</p>	Go to step 9.	The problem is solved.
<p>Step 9 Perform the motor (ADF pick and ADF feed) tests. See “Motor tests” on page 256.</p> <p>Are the motors working properly?</p>	Go to step 10.	Go to step 16.

Actions	Yes	No
<p>Step 10 Perform the sensor (ADF paper present and ADF scan) tests. See “Sensor tests” on page 257.</p> <p>Are the sensors properly functioning?</p>	Go to step 11.	Go to step 12.
<p>Step 11 If the ADF has an interval sensor, perform the sensor (ADF interval) tests. See “Sensor tests” on page 257.</p> <p>Are the sensors properly functioning?</p>	Go to step 14.	Go to step 12.
<p>Step 12 Inspect all the sensors for debris or dust.</p> <p>Is there dirt or debris in the sensors?</p>	Go to step 13.	Go to step 14.
<p>Step 13 Clean the sensors.</p> <p>Does the problem remain?</p>	Go to step 14.	The problem is solved.
<p>Step 14 Check the ADF mechanism sensor actuators for damage.</p> <p>Are the actuators jammed or damaged?</p>	Go to step 15.	Go to step 16.
<p>Step 15 Replace the ADF assembly. See “ADF unit removal” on page 402.</p> <p>Does the problem remain?</p>	Contact your next level of support.	The problem is solved.
<p>Step 16</p> <ul style="list-style-type: none"> a Reconnect the ADF cable to the controller board. b If applicable, reconnect the ADF cable to the ADF relay card. <p>Does the problem remain?</p>	Go to step 17.	The problem is solved.
<p>Step 17 If there is a separate ADF cable, then check it for continuity. Replace the cable if there is no continuity. See “ADF cable removal” on page 408.</p> <p>Does the problem remain?</p>	Go to step 18.	The problem is solved.

Actions	Yes	No
<p>Step 18</p> <p>Check the voltages and grounds on JADF1 on the controller board. See “Controller board” on page 469 for signal and voltage information.</p> <p>Are the signals or voltages present?</p>	<p>Replace the ADF assembly. See “ADF unit removal” on page 402.</p>	<p>Replace the controller board. See “Controller board removal” on page 320.</p>

29y paper jams

29y paper jam messages

Error code	Description	Action
290.11	ADF Cover Open Jam—Posted when ADF top cover is opened during ADF job.	Go to “ADF cover open service check” on page 128 .

ADF cover open service check

Actions	Yes	No
<p>Step 1</p> <p>Is the ADF cover properly closed?</p>	Go to step 3.	Go to step 2.
<p>Step 2</p> <p>Close the ADF cover.</p> <p>Does the problem go away?</p>	Issue resolved.	Go to step 3.
<p>Step 3</p> <p>Perform the ADF cover open sensor test. See “Scanner tests” on page 256.</p> <p>Does the sensor work properly?</p>	Go to step 4	Go to step 8.
<p>Step 4</p> <p>On the bottom of the ADF cover, inspect the ADF cover closed sensor actuator.</p> <p>Does it move freely?</p>	Go to step 6.	Go to step 5.
<p>Step 5</p> <p>Fix the actuator so it moves freely.</p> <p>Does this fix the problem?</p>	Issue resolved.	Go to step 6.

Actions	Yes	No
<p>Step 6</p> <p>Remove the ADF rear cover and inspect the ADF cover closed sensor for dirt and debris.</p> <p>Is there dirt and debris present?</p>	Go to step 7.	Go to step 8.
<p>Step 7</p> <p>Clean the dirt and debris from the sensor.</p> <p>Does this fix the issue?</p>	The problem is solved.	Go to step 8.
<p>Step 8</p> <p>Inspect the connections on the ADF relay card in the ADF.</p> <p>Are all the connections properly connected?</p>	Go to step 9.	Secure all the connections.
<p>Step 9</p> <p>Check the ADF cable for continuity.</p> <p>Is there continuity?</p>	Go to step 10.	Replace the ADF cable. See “ADF cable removal” on page 408.
<p>Step 10</p> <p>Check for signals or voltages from JADF1 on the controller board. Pin 14 and 16 should measure +24VDC. Pins 15 and 22 should measure +3.3VDC.</p> <p>Are there signals or voltages present?</p>	Replace the ADF. See “ADF unit removal” on page 402.	Replace the controller board. See “Controller board removal” on page 320.

45y paper jams

[x]-page jam, remove all pages from the output bin. Leave paper in bin. [45y.xx]

Paper jam in the finisher bin

- 1 Empty the standard bin.



- 2 Move the tamper arms to the sides.



- 3 Remove all jammed pages from inside the access areas.

Note: Make sure all paper fragments are removed.



- 4 If necessary, touch **Done** from the printer control panel to clear the message and continue printing.

Paper jam in the finisher rear door

- 1 Open the finisher rear door.



- Firmly grasp the jammed paper on each side, and then gently pull it out.

Note: Make sure all paper fragments are removed.



- Open the finisher trap door, remove any paper fragments inside the trap door.

Note: After removing any jammed paper in the finisher bin or in the finisher rear door, open the trap door to remove any paper fragments.

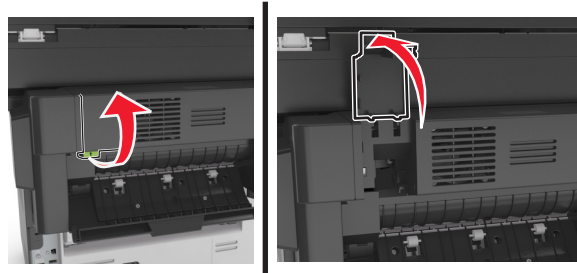

- Close the trap door.

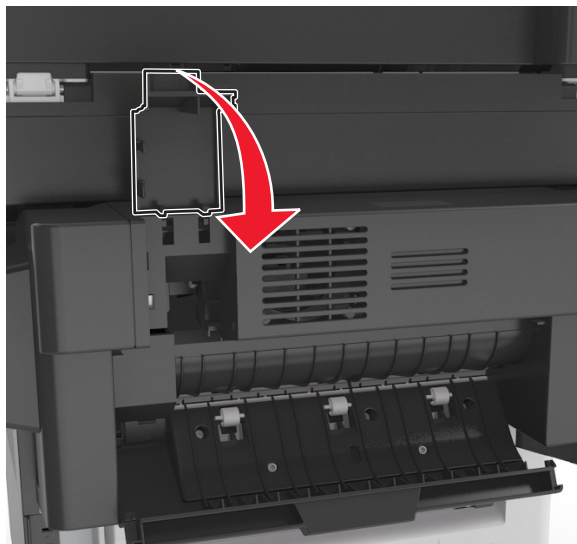

5 Close the finisher rear door.



6 If necessary, touch **Done** from the printer control panel to clear the message and continue printing.

Staple jam in the finisher

1 Open the staple access door.

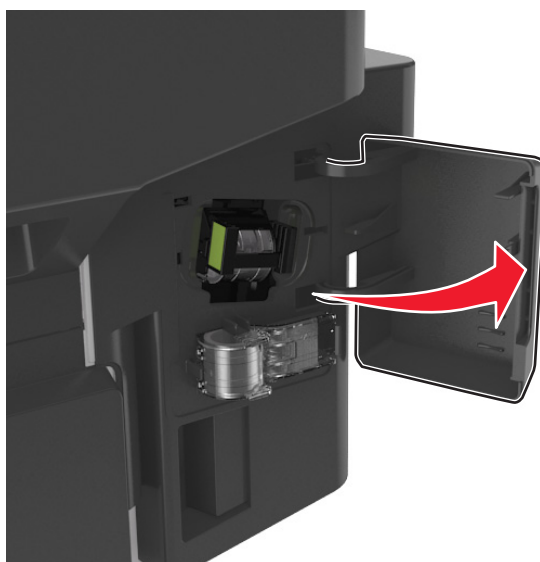

2 Pull out the staple cartridge from the finisher.

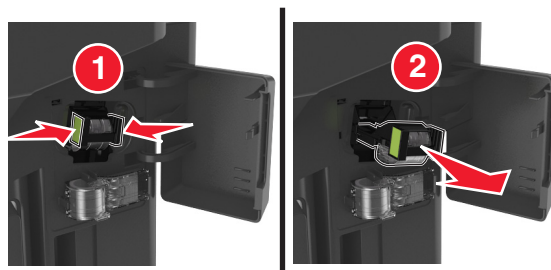

- 3** Lift the staple guard, and then remove any jammed or loose staples.

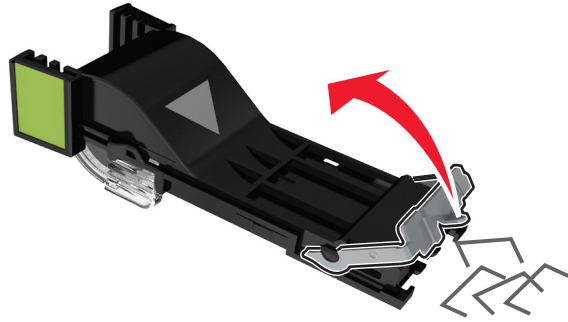

- 4** Press down the staple guard until it *clicks* into place.

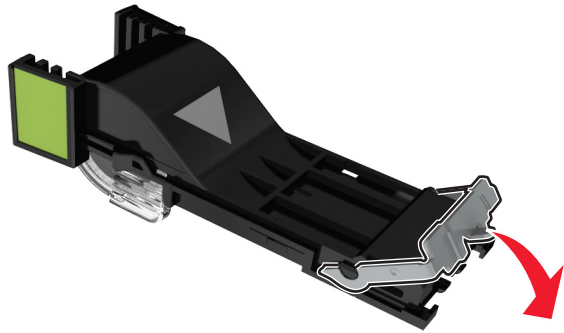

- 5** Insert stapler cartridge back into the finisher until it *clicks* into place.

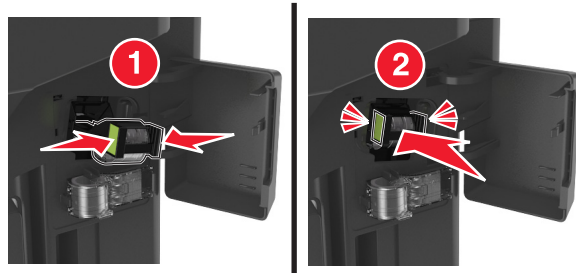

6 Close the staple access door.

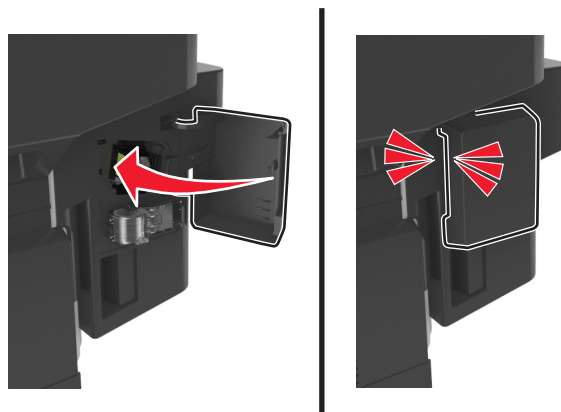

7 If necessary, touch **Done** from the printer control panel to clear the message and continue printing.

[x]-page jam, remove all pages from the finisher's accumulator. Leave paper in bin.
[45y.xx]

Paper jam in the finisher bin

1 Empty the standard bin.



2 Move the tamper arms to the sides.



- 3 Remove all jammed pages from inside the access areas.

Note: Make sure all paper fragments are removed.



- 4 If necessary, touch **Done** from the printer control panel to clear the message and continue printing.

Paper jam in the finisher rear door

- 1 Open the finisher rear door.



- 2 Firmly grasp the jammed paper on each side, and then gently pull it out.

Note: Make sure all paper fragments are removed.



3 Open the finisher trap door, and then remove any paper fragments from inside the trap door.

Note: After removing any jammed paper in the finisher rear door, open the trap door to remove any paper fragments.

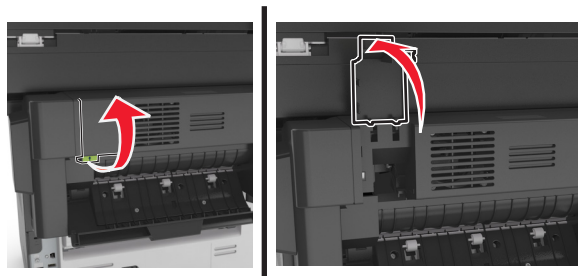

4 Close the trap door.

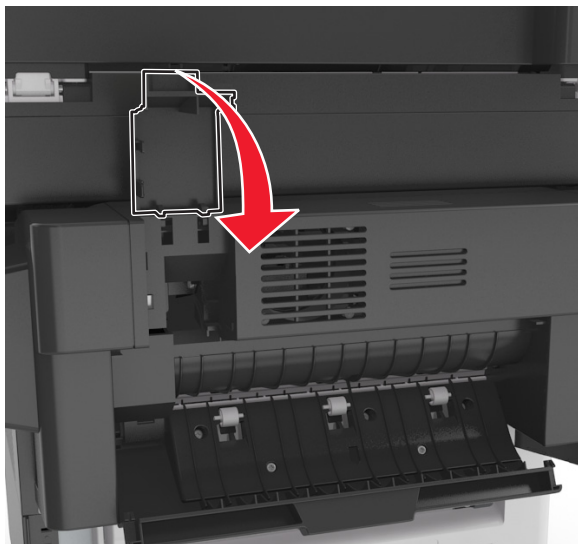

5 Close the finisher rear door.



6 If necessary, touch **Done** from the printer control panel to clear the message and continue printing.

451 paper jam messages

Error code	Description	Action
451.01	Media remains detected by the sensor (stapler pass through) after power on.	See “Finisher jam service check” on page 140.
451.03	The media fed did not reach the sensor (stapler pass through).	
451.05	While feeding, the media remains detected by the sensor (stapler pass through).	
451.09	Page In Output is never received from the staple finisher.	
451.10	Invalid Page ID returned by the staple finisher.	
451.41	Staple finisher main motor stalled.	
451.42	Staple finisher main motor did not reach the required speed.	
451.43	Staple finisher took too long to ramp up the stapler main motor.	

452–453 paper jam messages

Error code	Description	Action
452.73	Staple finisher left tamper failed to leave its home position.	See “Stapler left tamper jam service check” on page 142.
452.74	Staple finisher left tamper failed to reach its home position.	
453.75	Staple finisher right tamper failed to leave its home position.	
453.76	Staple finisher right tamper failed to reach its home position.	

454 paper jam messages

Error code	Description	Action
454.41	Staple finisher ejector motor stalled.	See “Ejector jam service check” on page 139.
454.42	Staple finisher ejector motor did not reach the required speed.	
454.43	Staple finisher took too long to ramp up the stapler ejector motor.	
454.53	Staple finisher ejector motor went over the normal speed.	
454.77	Staple finisher ejector failed to leave its home position.	
454.78	Staple finisher ejector failed to reach its home position.	

456 paper jam messages

Error code	Description	Action
456.03	Failure to staple—media did not reach the stapler throat.	See “Stapler carriage jam service check” on page 141.
456.07	Paper jam—media remains detected in the stapler throat.	
456.83	Homing failure occurred on the stapler unit.	
456.84	Staple unit jam while stapling—media remains detected by the home position sensor.	
456.85	Staple unit jam while stapling—the staple unit is unable to return to home position.	
456.86	Failure to staple—stapler cartridge is detected as empty.	

457 paper jam messages

Error code	Description	Action
457.87	Stapler failed to prime the staple wire after a stapling operation.	See “Stapler priming jam service check” on page 142.
457.88	Stapler failed to prime the staple wire after a homing operation.	
457.89	Stapler failed to prime after a stapling operation.	
457.90	Stapler failed to prime before a stapling operation.	

Ejector jam service check

Action	Yes	No
<p>Step 1</p> <p>Open the stapler service cover, and then reseal the sensor (stapler paddle HP) connector on the controller card. POR the machine.</p> <p>Does the error remain?</p>	Go to step 2.	The problem is solved.
<p>Step 2</p> <p>Swap the sensor (stapler paddle HP) and sensor (stapler right tamper HP). POR the machine.</p> <p>Does the same error occur?</p>	Go to step 3.	If a 453.xx error occurs, then replace the motor. See “Sensor (stapler right tamper HP) removal” on page 462.
<p>Step 3</p> <p>Reseat the paddle motor connector on the controller card. Then reseal also the connector on the paddle motor. POR the machine.</p> <p>Does the error remain?</p>	<p>Replace the motor. See “Stapler paddle motor removal” on page 433.</p> <p>If the error persists, then go to step 4.</p>	The problem is solved.
<p>Step 4</p> <p>Check the stapler interface cable. If damaged, then replace the cable. See “Stapler interface cable removal” on page 443.</p> <p>Reseat the interface cable on the controller card, and then POR the machine.</p> <p>Does the error remain?</p>	Go to step 5.	The problem is solved.
<p>Step 5</p> <p>Check the tamper main assembly:</p> <ul style="list-style-type: none"> • Check the paddle mechanism for damage. • Check for worn-out and lost parts. Make sure all parts within the assembly are properly installed. <p>Are the components functional and free of damage?</p>	Go to step 6.	Replace the tamper main assembly. See “Tamper main assembly removal” on page 455.

Action	Yes	No
<p>Step 6 Reseat all connectors on the controller card, and then POR the machine.</p> <p>Does the error remain?</p>	<p>Replace the stapler controller card. See “Stapler controller card removal” on page 437.</p>	<p>The problem is solved.</p>

Finisher jam service check

Action	Yes	No
<p>Step 1 Open the rear door and check the flag of the sensor (stapler pass through). If damaged, then replace the sensor. See “Sensor (stapler pass through) removal” on page 453.</p> <p>Remove the left cover, reseat the sensor connector on the controller card, and then POR the machine.</p> <p>Does the error remain?</p>	<p>Go to step 2.</p>	<p>The problem is solved.</p>
<p>Step 2 Check the sensor (stapler pass through) for proper operation. Enter Diagnostics Menu and navigate to: FINISHER TESTS > Sensor Test Select Pass and Media.</p> <p>Does the status shown on the control panel change each time the sensor is toggled?</p>	<p>Go to step 3.</p>	<p>Replace the sensor. See “Sensor (stapler pass through) removal” on page 453.</p>
<p>Step 3 Open the stapler service cover, reseat all connectors on the controller card, and then POR the machine.</p> <p>Does the error remain?</p>	<p>Replace the controller card. See “Stapler controller card removal” on page 437.</p> <p>If the error persists, then go to step 4.</p>	<p>The problem is solved.</p>
<p>Step 4 Check the paper path of the stapler for obstructions.</p> <p>Is it free of obstructions?</p>	<p>Go to step 5.</p>	<p>Remove all obstructions along the paper path.</p>
<p>Step 5 Check the paper path for damage.</p> <p>Is the paper path free of damage?</p>	<p>If the error remains, then contact the next level of support.</p>	<p>Replace the staple finisher option. See “Staple finisher option removal” on page 421.</p>

Stapler carriage jam service check

Action	Yes	No
<p>Step 1</p> <p>Open the stapler service cover. Reseat the sensor (stapler throat) cable. Then reseat also the other end of the cable on the controller card, and then POR the machine.</p> <p>Does the error remain?</p>	<p>Replace the stapler accumulator assembly. See “Stapler accumulator assembly removal” on page 462.</p> <p>POR the machine. If the error persists, then go to step 2.</p>	<p>The problem is solved.</p>
<p>Step 2</p> <p>Open the stapler right cover. Reseat the stapler carriage assembly cables. Then reseat also the other end of the cables on the controller card, and then POR the machine.</p> <p>Does the error remain?</p>	<p>Go to step 3.</p>	<p>The problem is solved.</p>
<p>Step 3</p> <p>Enter Diagnostic mode and navigate to: FINISHER TESTS > Staple Test</p> <p>Does the error remain?</p>	<p>Replace the stapler carriage assembly. See “Stapler carriage assembly removal” on page 427.</p> <p>POR the machine. If the error persists, then go to step 4.</p>	<p>The problem is solved.</p>
<p>Step 4</p> <p>Check the stapler interface cable. If damaged, then replace the cable. See “Stapler interface cable removal” on page 443.</p> <p>Reseat the interface cable on the controller card, and then POR the machine.</p> <p>Does the error remain?</p>	<p>Go to step 5.</p>	<p>The problem is solved.</p>
<p>Step 5</p> <p>Reseat all connectors on the controller card, and then POR the machine.</p> <p>Does the error remain?</p>	<p>Replace the stapler controller card. See “Stapler controller card removal” on page 437.</p>	<p>The problem is solved.</p>

Stapler priming jam service check

Action	Yes	No
<p>Step 1</p> <p>Open the stapler right cover. Reseat the stapler carriage assembly cables. Then reseat also the other end of the cables on the controller card, and then POR the machine.</p> <p>Does the error remain?</p>	Go to step 2.	The problem is solved.
<p>Step 2</p> <p>Enter Diagnostic mode, and then navigate to: FINISHER TESTS > Staple Test</p> <p>Does the error remain?</p>	<p>Replace the stapler carriage assembly. See “Stapler carriage assembly removal” on page 427.</p> <p>POR the machine. If the error persists, then go to step 3.</p>	The problem is solved.
<p>Step 3</p> <p>Check the stapler interface cable. If damaged, then replace the cable. See “Stapler interface cable removal” on page 443.</p> <p>Reseat the interface cable on the controller card, and then POR the machine.</p> <p>Does the error remain?</p>	Go to step 4.	The problem is solved.
<p>Step 4</p> <p>Reseat all connectors on the controller card, and then POR the machine.</p> <p>Does the error remain?</p>	Replace the stapler controller card. See “Stapler controller card removal” on page 437.	The problem is solved.

Stapler left tamper jam service check

Action	Yes	No
<p>Step 1</p> <p>Remove the stapler top cover. Reseat the connector of the sensor (stapler left tamper HP). Then reseat also the sensor connector on the controller card.</p> <p>Does the error remain?</p>	Go to step 2.	The problem is solved.
<p>Step 2</p> <p>Swap the sensor (stapler left tamper HP) and sensor (stapler right tamper HP).</p> <p>Does the same error occur?</p>	Go to step 3.	If a 453.xx error occurs, then replace the sensor. See “Sensor (stapler right tamper HP) removal” on page 462.

Action	Yes	No
<p>Step 3</p> <p>Reseat the connectors of the right and left tamper motors. Then reseat also the motor connectors on the controller card.</p> <p>Does the error remain?</p>	Go to step 4.	The problem is solved.
<p>Step 4</p> <p>Swap the stapler left and right tamper motors.</p> <p>Does the same error occur?</p>	Go to step 5.	If a 453.xx error occurs, then replace the motor. See “Stapler right tamper motor removal” on page 438.
<p>Step 5</p> <p>Check the stapler interface cable. If damaged, then replace the cable. See “Stapler interface cable removal” on page 443.</p> <p>Reseat the interface cable on the controller card, and then POR the machine.</p> <p>Does the error remain?</p>	Go to step 6.	The problem is solved.
<p>Step 6</p> <p>Remove the tamper sub-assembly. Check the tamper drive belts:</p> <ul style="list-style-type: none"> • Inspect the belts for wear or damage. • Inspect the belt tension spring and make sure it is properly installed and aligned. <p>Are the components functional and free of damage?</p>	Go to step 7.	Replace the tamper drive belts. See “Tamper drive belt removal” on page 458.
<p>Step 7</p> <p>Check the following:</p> <ul style="list-style-type: none"> • Manually move the left and right tamper arms and check if they can move freely. • Check the tamper home position flags for damage. <p>Are the components functional and free of damage?</p>	Go to step 8.	Replace the tamper sub-assembly. See “Tamper sub-assembly removal” on page 456. POR the machine. If the error remains, then go to step 9.
<p>Step 8</p> <p>Reseat all connectors on the controller card, and then POR the machine.</p> <p>Does the error remain?</p>	Replace the stapler controller card. See “Stapler controller card removal” on page 437.	The problem is solved.

Stapler right tamper jam service check

Action	Yes	No
<p>Step 1</p> <p>Remove the stapler top cover. Reseat the connector of the sensor (stapler right tamper HP). Then reseat also the sensor connector on the controller card.</p> <p>Does the error remain?</p>	Go to step 2.	The problem is solved.
<p>Step 2</p> <p>Swap the sensor (stapler left tamper HP) and sensor (stapler right tamper HP).</p> <p>Does the same error occur?</p>	Go to step 3.	If a 452.xx error occurs, then replace the sensor. See “Sensor (stapler left tamper HP) removal” on page 463.
<p>Step 3</p> <p>Reseat the connectors of the right and left tamper motors. Then reseat also the motor connectors on the controller card.</p> <p>Does the error remain?</p>	Go to step 4.	The problem is solved.
<p>Step 4</p> <p>Swap the stapler left and right tamper motors.</p> <p>Does the same error occur?</p>	Go to step 5.	If a 452.xx error occurs, then replace the motor. See “Stapler left tamper motor removal” on page 437.
<p>Step 5</p> <p>Check the stapler interface cable. If damaged, then replace the cable. See “Stapler interface cable removal” on page 443.</p> <p>Reseat the interface cable on the controller card, and then POR the machine.</p> <p>Does the error remain?</p>	Go to step 6.	The problem is solved.
<p>Step 6</p> <p>Remove the tamper sub-assembly. Check the tamper drive belts:</p> <ul style="list-style-type: none"> • Inspect the belts for wear or damage. • Inspect the belt tension spring and make sure it is properly installed and aligned. <p>Are the components functional and free of damage?</p>	Go to step 7.	Replace the tamper drive belts. See “Tamper drive belt removal” on page 458.

Action	Yes	No
<p>Step 7</p> <p>Check the following:</p> <ul style="list-style-type: none"> Manually move the left and right tamper arms and check if they can move freely. Check the tamper home position flags for damage. <p>Are the components functional and free of damage?</p>	Go to step 8.	<p>Replace the tamper sub-assembly. See “Tamper sub-assembly removal” on page 456.</p> <p>POR the machine. If the error remains, then go to step 9.</p>
<p>Step 8</p> <p>Reseat all connectors on the controller card, and then POR the machine.</p> <p>Does the error remain?</p>	<p>Replace the stapler controller card. See “Stapler controller card removal” on page 437.</p>	The problem is solved.

Understanding the printer messages

Cartridge, imaging unit mismatch [41.xy]

Install a toner cartridge that matches the region number of the printer. x indicates the value of the printer region. y indicates the value of the cartridge region. x and y can have the following values:

List of printer and toner cartridge regions

Region number	Region
0	Global
1	United States, Canada
2	European Economic Area (EEA), Switzerland
3	Asia Pacific, Australia, New Zealand
4	Latin America
5	Africa, Middle East, rest of Europe
9	Invalid region

Notes:

- The x and y values are the .xy of the error code shown on the printer control panel.
- The x and y values must match for printing to continue.

Cartridge low [88.xy]

You may need to order a replacement toner cartridge. If necessary, touch **Continue** on the printer control panel to clear the message and continue printing.

Cartridge nearly low [88.xy]

If necessary, touch **Continue** on the printer control panel to clear the message and continue printing.

Cartridge very low, [x] estimated pages remain [88.xy]

You may need to replace the toner cartridge very soon. For more information, see the “Replacing supplies” section of the *User’s Guide*.

If necessary, touch **Continue** on the printer control panel to clear the message and continue printing.

Change [paper source] to [custom type name] load [orientation]

Try one or more of the following:

- Load the correct size and type of paper in the tray, then specify the paper size and type in the Paper menu on the printer control panel, and then touch **Finished changing paper**.
- Touch **Reset active bin** to reset the active tray for a linked set of trays.
- Cancel the print job.

Change [paper source] to [custom string] load [orientation]

Try one or more of the following:

- Load the correct size and type of paper in the tray, then specify the paper size and type in the Paper menu on the printer control panel, and then touch **Finished changing paper**.
- Touch **Reset active bin** to reset the active tray for a linked set of trays.
- Cancel the print job.

Change [paper source] to [paper size] load [orientation]

Try one or more of the following:

- Load the correct size and type of paper in the tray, then specify the paper size and type in the Paper menu on the printer control panel, and then touch **Finished changing paper**.
- Touch **Reset active bin** to reset the active tray for a linked set of trays.
- Cancel the print job.

Change [paper source] to [paper type] [paper size] load [orientation]

Try one or more of the following:

- Load the correct size and type of paper in the tray, then specify the paper size and type in the Paper menu on the printer control panel, and then touch **Finished changing paper**.
- Touch **Reset active bin** to reset the active tray for a linked set of trays.
- Cancel the print job.

Check tray [x] connection

Try one or more of the following:

- Turn off the printer, and then turn it back on.

If the error occurs a second time, then:

- 1 Turn off the printer.
- 2 Unplug the power cord from the electrical outlet.
- 3 Remove the indicated tray.
- 4 Reattach the tray.
- 5 Connect the power cord to a properly grounded electrical outlet.
- 6 Turn the printer back on.

If the error occurs again, then:

- 1 Turn off the printer.
 - 2 Unplug the power cord from the electrical outlet.
 - 3 Remove the tray.
 - 4 Contact customer support.
- From the printer control panel, touch **Continue** to clear the message and resume the job.

Close front door

Close the front door of the printer.

Close flatbed cover and load originals if restarting job [2yy.xx]

Try one or more of the following:

- Touch **Scan from automatic feeder** to continue scanning from the ADF immediately after the last successful scan job.
- Touch **Scan from flatbed** to continue scanning from the scanner glass immediately after the last successful scan job.
- Touch **Finish job without further scanning** to end the last successful scan job.

Note: This does not cancel the scan job. All successfully scanned pages will be processed further for copying, faxing, or e-mailing.

- Touch **Cancel job** to clear the message and cancel the scan job.

Complex page, some data may not have printed [39]

Try one or more of the following:

- From the printer control panel, touch **Continue** to ignore the message and continue printing.
- Cancel current print job.
- Install additional printer memory.

Configuration change, some held jobs were not restored [57]

Held jobs are invalidated because of the following possible changes in the printer:

- The printer firmware has been updated.
- The tray for the print job has been removed.
- The print job is sent from a flash drive that is no longer attached to the USB port.
- The printer hard disk contains print jobs that were stored when the hard disk was installed in a different printer model.

From the printer control panel, touch **Continue** to clear the message.

Defective flash detected [51]

Try one or more of the following:

- Replace the defective flash memory card.
- From the printer control panel, touch **Continue** to ignore the message and continue printing.
- Cancel the current print job.

Disk full [62]

Try one or more of the following:

- From the printer control panel, touch **Continue** to clear the message and continue processing.
- Delete fonts, macros, and other data stored in the printer hard disk.
- Install a printer hard disk with larger capacity.

Disk must be formatted for use in this device

From the printer control panel, touch **Format disk** to format the printer hard disk and clear the message.

Note: Formatting deletes all the files stored in the printer hard disk.

Disk near full. Securely clearing disk space.

Try one or more of the following:

- Touch **Continue** to clear the message and continue printing.
- Delete fonts, macros, and other data stored on the printer hard disk.
- Install a hard disk with higher capacity.

Error reading USB drive. Remove USB.

An unsupported USB device is inserted. Remove the USB device, and then insert a supported one.

Error reading USB hub. Remove hub.

An unsupported USB hub has been inserted. Remove the USB hub, and then install a supported one.

Fax memory full

From the printer control panel, touch **Continue** to clear the message.

Fax partition inoperative. Contact system administrator.

Try one or more of the following:

- From the printer control panel, touch **Continue** to clear the message.
- Turn off the printer, and then turn it back on. If the message appears again, then contact your system support person.

Fax server 'To Format' not set up. Contact system administrator.

Try one or more of the following:

- From the printer control panel, touch **Continue** to clear the message.
- Complete the Fax Server setup. If the message appears again, then contact your system support person.

Fax Station Name not set up. Contact system administrator.

Try either of the following:

- From the printer control panel, touch **Continue** to clear the message.
- Complete the Analog Fax setup. If the message appears again after completing the setup, then contact your system support person.

Fax Station Number not set up. Contact system administrator.

Try one or more of the following:

- From the printer control panel, touch **Continue** to clear the message.
- Complete the Analog Fax setup. If the message appears again after completing the setup, then contact your system support person.

Imaging unit low [84.xy]

You may need to order a replacement imaging unit. If necessary, select **Continue** on the printer control panel to clear the message and continue printing.

Imaging unit nearly low [84.xy]

If necessary, touch **Continue** on the printer control panel to clear the message and continue printing.

Imaging unit very low, [x] estimated pages remain [84.xy]

You may need to replace the imaging unit very soon. For more information, see the “Replacing supplies” section of the *User's Guide*.

If necessary, touch **Continue** on the printer control panel to clear the message and continue printing.

Incompatible tray [x] [59]

Try one or more of the following:

- Remove the indicated tray.
- From the printer control panel, touch **Continue** to clear the message and continue printing without using the indicated tray.

Incorrect paper size, open [paper source] [34]

Try one or more of the following:

- Load the correct size and type of paper in the tray, and then specify the paper size and type in the Paper menu on the printer control panel.
- Make sure the correct paper size and type are specified in Print Properties or the Print dialog settings.
- Check if the paper size is correctly set. For example, if MP Feeder Size is set to Universal, then make sure the paper is large enough for the data being printed.
- Check the length and width guides and make sure the paper is loaded properly in the tray.
- From the printer control panel, touch **Continue** to clear the message and print using a different tray.
- Cancel the print job.

Insufficient memory to collate job [37]

Try one or more of the following:

- From the printer control panel, touch **Continue** to print the part of the job already stored and begin collating the rest of the print job.
- Cancel the current print job.

Insufficient memory for Flash Memory Defragment operation [37]

Try one or more of the following:

- From the printer control panel, touch **Continue** to stop the defragmentation and continue printing.
- Delete fonts, macros, and other data in the printer memory.
- Install additional printer memory.

Insufficient memory, some Held Jobs were deleted [37]

From the printer control panel, touch **Continue** to clear the message.

Insufficient memory, some held jobs will not be restored [37]

Try one or more of the following:

- From the printer control panel, touch **Continue** to clear the message.
- Delete other held jobs to free up additional printer memory.

Insufficient memory to support Resource Save feature [35]

Install additional printer memory or touch **Continue** to disable Resource Save, clear the message, and continue printing.

Load [paper source] with [custom type name] [paper orientation]

Try one or more of the following:

- Load the tray or feeder with the correct size and type of paper.
- To use the tray with the correct paper size or type, touch **Finished loading paper** on the printer control panel.

Note: If the printer detects a tray that has the correct paper size and type, then it feeds from that tray. If the printer cannot detect a tray that has the correct paper size and type, then it prints from the default paper source.

- Cancel the current job.

Load [paper source] with [custom string] [paper orientation]

Try one or more of the following:

- Load the indicated tray or feeder with the correct size and type of paper.
- To use the tray with the correct paper size or type, touch **Finished loading paper** on the printer control panel.

Note: If the printer finds a tray that has the correct paper size and type, then it feeds from that tray. If the printer cannot find a tray with the correct paper type and size, then it prints from the default paper source.

- Cancel the current job.

Load [paper source] with [paper size] [paper orientation]

Try one or more of the following:

- Load the specified tray or feeder with the correct size of paper.
- To use the tray or feeder with the correct size of paper, touch **Finished loading paper** on the printer control panel.

Note: If the printer finds a tray or feeder that has the correct size of paper, then it feeds from that tray or feeder. If the printer cannot find a tray or feeder with the correct size of paper, then it prints from the default paper source.

- Cancel the current job.

Load [paper source] with [paper type] [paper size] [paper orientation]

Try one or more of the following:

- Load the specified tray or feeder with the correct size and type of paper.
- To use the tray or feeder with the correct size and type of paper, touch **Finished loading paper** on the printer control panel.

Note: If the printer finds a tray or feeder that has the correct size and type of paper, then it feeds from that tray or feeder. If the printer cannot find a tray or feeder with the correct size and type of paper, then it prints from the default paper source.

- Cancel the current job.

Load Manual Feeder with [custom type name] [paper orientation]

Try one or more of the following:

- Load the feeder with the correct size and type of paper.
- From the printer control panel, touch **Prompt each page, paper loaded** or **Do not prompt, paper loaded** to clear the message and continue printing.
- From the printer control panel, touch **Automatically select paper** to use the paper loaded in the tray.
- Cancel the print job.

Load Manual Feeder with [custom string] [paper orientation]

Try one or more of the following:

- Load the feeder with the correct size and type of paper.
- From the printer control panel, touch **Prompt each page, paper loaded** or **Do not prompt, paper loaded** to clear the message and continue printing.
- From the printer control panel, touch **Automatically select paper** to use the paper loaded in the tray.
- Cancel the print job.

Load Manual Feeder with [paper size] [paper orientation]

Try one or more of the following:

- Load the feeder with the correct size of paper.
- From the printer control panel, touch **Prompt each page, paper loaded** or **Do not prompt, paper loaded** to clear the message and continue printing.
- From the printer control panel, touch **Automatically select paper** to use the paper loaded in the tray.
- Cancel the print job.

Load Manual Feeder with [paper type] [paper size] [paper orientation]

Try one or more of the following:

- Load the feeder with the correct size and type of paper.
- From the printer control panel, touch **Prompt each page, paper loaded** or **Do not prompt, paper loaded** to clear the message and continue printing.

- From the printer control panel, touch **Automatically select paper** to use the paper loaded in the tray.
- Cancel the print job.

Maintenance kit low [80.xy]

You may need to order a maintenance kit. For more information, contact customer support at <http://support.lexmark.com> or your service representative. If necessary, touch **Continue** to clear the message and continue printing.

Maintenance kit nearly low [80.xy]

For more information, contact customer support at <http://support.lexmark.com> or your service representative. If necessary, touch **Continue** to clear the message and continue printing.

Maintenance kit very low, [x] estimated pages remain [80.xy]

You may need to replace the maintenance kit very soon. For more information, contact customer support at <http://support.lexmark.com> or your service representative. If necessary, touch **Continue** to clear the message and continue printing.

Memory full [38]

Try one or more of the following:

- From the printer control panel, touch **Cancel job** to clear the message.
- Install additional printer memory.

Memory full, cannot print faxes

From the printer control panel, touch **Continue** to clear the message without printing. Held faxes attempt to print after the printer is restarted.

Memory full, cannot send faxes

- 1 From the printer control panel, touch **Continue** to clear the message and cancel the fax job.
- 2 Try one or more of the following:
 - Reduce the fax resolution, and then resend the fax job.
 - Reduce the number of pages in the fax, and then resend the fax job.

Network [x] software error [54]

Try one or more of the following:

- From the printer control panel, touch **Continue** to continue printing.
- Turn off the printer, wait for about 10 seconds, and then turn the printer back on.
- Update the network firmware in the printer or print server. For more information, contact customer support.

No analog phone line connected to modem, fax is disabled.

Connect the printer to an analog phone line.

Non-Lexmark [supply type], see *User's Guide* [33.xy]

Note: The supply type can be a toner cartridge or the imaging unit.

The printer has detected a non-Lexmark supply or part installed in the printer.

Your Lexmark printer is designed to function best with genuine Lexmark supplies and parts. Use of third-party supplies or parts may affect the performance, reliability, or life of the printer and its imaging components.

All life indicators are designed to function with Lexmark supplies and parts, and may deliver unpredictable results if third-party supplies or parts are used. Imaging component usage beyond the intended life may damage your Lexmark printer or associated components.

Warning—Potential Damage: Use of third-party supplies or parts can affect warranty coverage. Damage caused by the use of third-party supplies or parts may not be covered by the warranty.

To accept any and all of these risks, and to proceed with the use of non-genuine supplies or parts in your printer, press and hold  and # on the printer control panel simultaneously for 15 seconds to clear the message and continue printing.

If you do not wish to accept these risks, then remove the third-party supply or part from your printer, and then install a genuine Lexmark supply or part.

Note: For the list of supported supplies, see the “Ordering supplies” section of the *User's Guide* or visit www.lexmark.com.

Not enough free space in flash memory for resources [52]

Try one or more of the following:

- From the printer control panel, touch **Continue** to clear the message and continue printing.
- Delete fonts, macros, and other data stored in the flash memory.
- Install a flash memory card with larger capacity.

Note: Downloaded fonts and macros not previously stored in the flash memory are deleted.

Paper changes needed

Try one or more of the following:

- From the printer control panel, touch **Prompt for each page** to continue printing.
- Touch **Use current supplies** to continue printing using the paper loaded in the tray.
- Cancel the current print job.

Parallel port [x] disabled [56]

Try one or more of the following:

- From the printer control panel, touch **Continue** to clear the message.
- Enable the parallel port. From the printer control panel, navigate to:
Network/Ports > Parallel [x] > Parallel Buffer > Auto

Note: The printer discards any data received through the parallel port.

Printer had to restart. Last job may be incomplete.

From the printer control panel, touch **Continue** to clear the message and continue printing.

For more information, visit <http://support.lexmark.com> or contact customer support.

Remove defective disk [61]

Remove and replace the defective printer hard disk.

Remove paper from standard output bin

Remove the paper stack from the standard bin.

Replace defective imaging unit [31.xy]

Replace the defective imaging unit to clear the message. For more information, see the instruction sheet that came with the supply.

Note: If you do not have a replacement imaging unit, then see the “Ordering supplies” section of the *User’s Guide* or visit www.lexmark.com.

Replace cartridge, 0 estimated pages remain [88.xy]

Replace the toner cartridge. For more information, see the instruction sheet that came with the supply.

Note: If you do not have a replacement toner cartridge, then see the “Ordering supplies” section of the *User’s Guide*.

Replace imaging unit, 0 estimated pages remain [84.xy]

Replace the imaging unit. For more information, see the instruction sheet that came with the supply.

Replace maintenance kit, 0 estimated pages remain [80.xy]

Contact customer support at <http://support.lexmark.com> or your service representative, and then report the message. The printer is scheduled for maintenance.

Replace all originals if restarting job.

Try one or more of the following:

- Touch **Cancel job** to clear the message and cancel the scan job.
- Touch **Scan from automatic feeder** to continue scanning from the ADF immediately after the last successful scan job.
- Touch **Scan from flatbed** to continue scanning from the scanner immediately after the last successful scan job.
- Touch **Finish job without further scanning** to end the last successful scan job.
- Touch **Restart job** to restart the scan job with the same settings from the previous scan job.

Reinstall missing or unresponsive cartridge [31.xy]

Try one or more of the following:

- Check if the toner cartridge is missing. If missing, install the toner cartridge.
For information on installing the cartridge, see the “Replacing supplies” section of the *User’s Guide*.
- If the toner cartridge is installed, then remove the unresponsive toner cartridge, and then reinstall it.
Note: If the message appears after reinstalling the supply, then the cartridge is defective. Replace the toner cartridge.

Reinstall missing or unresponsive imaging unit [31.xy]

Try one or more of the following:

- Check if the imaging unit is missing. If missing, install the imaging unit.
For information on installing the imaging unit, see the “Replacing supplies” section of the *User’s Guide*.
- If the imaging unit is installed, then remove the unresponsive imaging unit, and then reinstall it.
Note: If the message appears after reinstalling the supply, then the imaging unit is defective. Replace the imaging unit.

Replace unsupported cartridge [32.xy]

Remove the toner cartridge, and then install a supported one to clear the message and continue printing. For more information, see the instruction sheet that came with the supply or see the “Replacing supplies” section of the *User’s Guide*.

Note: If you do not have a replacement cartridge, then see the “Ordering supplies” section of the *User’s Guide* or visit www.lexmark.com.

Replace unsupported imaging unit [32.xy]

Remove the imaging unit, and then install a supported one to clear the message and continue printing. For more information, see the instruction sheet that came with the supply or see the “Replacing supplies” section of the *User’s Guide*.

Note: If you do not have a replacement imaging unit, then see the “Ordering supplies” section of the *User’s Guide* or visit www.lexmark.com.

Restore held jobs?

Try one or more of the following:

- From the printer control panel, touch **Restore** to restore all held jobs stored in the printer hard disk.
- From the printer control panel, touch **Do not restore** if you do not want to restore any of the print jobs.

Scanner automatic feeder cover open

Close the ADF cover.

Scanner disabled by admin [840.01]

Print without the scanner, or contact your system support person.

Scanner disabled. Contact system administrator if problem persists. [840.02]

Try one or more of the following:

- Touch **Continue with scanner disabled** to return to the home screen, and then contact your system support person.
- Touch **Reboot and automatically enable scanner** to cancel the job.

Note: This attempts to enable the scanner.

Scanner jam, remove all originals from the scanner [2yy.xx]

Remove the jammed paper from the scanner.

Scanner jam, remove jammed originals from the scanner [2yy.xx]

Remove the jammed paper from the scanner.

Serial port [x] disabled [56]

Try one or more of the following:

- From the printer control panel, touch **Continue** to clear the message.
The printer discards any data received through the specified serial port.
- Make sure Serial Buffer is not set to Disabled.
- From the printer control panel, set Serial Buffer to Auto in the Serial [x] menu.

SMTP server not set up. Contact system administrator.

From the printer control panel, touch **Continue** to clear the message.

Note: If the message appears again, then contact your system support person.

Some held jobs were not restored

From the printer control panel, touch **Continue** to delete the indicated job.

Note: Held jobs that are not restored remain in the printer hard disk and are inaccessible.

Standard network software error [54]

Try one or more of the following:

- From the printer control panel, touch **Continue** to continue printing.
- Turn off the printer, and then turn it back on.
- Update the network firmware in the printer or print server. For more information, contact customer support.

Standard USB port disabled [56]

Try one or more of the following:

- From the printer control panel, touch **Continue** to clear the message.
- Enable the USB port. From the printer control panel, navigate to:
Network/Ports > USB Buffer > Auto

Note: The printer discards any data received through the USB port.

Supply needed to complete job

Do either of the following:

- Install the missing supply to complete the job.
- Cancel the current job.

Too many flash options installed [58]

- 1 Turn off the printer.
- 2 Unplug the power cord from the electrical outlet.
- 3 Remove the extra flash memory.
- 4 Connect the power cord to a properly grounded electrical outlet.
- 5 Turn the printer back on.

Too many trays attached [58]

- 1 Turn off the printer.
- 2 Unplug the power cord from the electrical outlet.
- 3 Remove the extra trays.

- 4 Connect the power cord to a properly grounded electrical outlet.
- 5 Turn the printer back on.

Unformatted flash detected [53]

Try one or more of the following:

- From the printer control panel, touch **Continue** to stop the defragmentation and continue printing.
- Format the flash memory.

Note: If the error message remains, then the flash memory may be defective and needs to be replaced.

Unsupported disk

Remove the unsupported printer hard disk, and then insert a supported one.

Unsupported option in slot [x] [55]

- 1 Turn off the printer.
- 2 Unplug the power cord from the electrical outlet.
- 3 Remove the unsupported option card from the printer controller board, and then replace it with a supported card.
- 4 Connect the power cord to a properly grounded electrical outlet.
- 5 Turn the printer back on.

USB port [x] disabled [56]

From the printer control panel, touch **Continue** to clear the message.

Notes:

- The printer discards any data received through the USB port.
- Make sure the USB Buffer menu is not set to Disabled.

Weblink server not set up. Contact system administrator.

From the printer control panel, touch **Continue** to clear the message.

Note: If the message appears again, then contact your system support person.

User attendance messages

User attendance messages (0–99.99)

Error code	Description	Action
31.21	Missing or unresponsive imaging unit	Go to “Unresponsive imaging unit service check” on page 178.
31.25	Missing or unresponsive imaging unit	Go to “Unresponsive imaging unit service check” on page 178.
31.40	Missing or unresponsive toner cartridge	Go to “Unresponsive toner cartridge service check” on page 163.
31.41	Missing or unresponsive toner cartridge	Go to “Unresponsive toner cartridge service check” on page 163.
31.42	Missing or unresponsive toner cartridge	Go to “Unresponsive toner cartridge service check” on page 163.
31.43	Missing or unresponsive toner cartridge	Go to “Unresponsive toner cartridge service check” on page 163.
31.44	Missing or unresponsive toner cartridge	Go to “Unresponsive toner cartridge service check” on page 163.
31.45	Missing or unresponsive toner cartridge	Go to “Unresponsive toner cartridge service check” on page 163.
31.46	Missing or unresponsive toner cartridge	Go to “Unresponsive toner cartridge service check” on page 163.
31.60	Missing or unresponsive imaging unit	Go to “Unresponsive imaging unit service check” on page 178.
31.61	Missing or unresponsive imaging unit	Go to “Unresponsive imaging unit service check” on page 178.
31.62	Missing or unresponsive imaging unit	Go to “Unresponsive imaging unit service check” on page 178.
31.63	Missing or unresponsive imaging unit	Go to “Unresponsive imaging unit service check” on page 178.
31.64	Missing or unresponsive imaging unit	Go to “Unresponsive imaging unit service check” on page 178.
31.65	Missing or unresponsive imaging unit	Go to “Unresponsive imaging unit service check” on page 178.
31.66	Missing or unresponsive imaging unit	Go to “Unresponsive imaging unit service check” on page 178.
32.01	Unsupported cartridge.	Go to “Unsupported toner cartridge service check” on page 163.
32.01	Unsupported imaging unit	Go to “Unsupported imaging unit service check” on page 164.

Error code	Description	Action
32.05	Unsupported cartridge	Go to “Unsupported toner cartridge service check” on page 163.
32.05	Unsupported imaging unit	Go to “Unsupported imaging unit service check” on page 164.
32.08	Unsupported cartridge	Go to “Unsupported toner cartridge service check” on page 163.
32.10	Unsupported cartridge	Go to “Unsupported toner cartridge service check” on page 163.
32.11	Unsupported imaging unit	Go to “Unsupported imaging unit service check” on page 164.
32.13	Unsupported cartridge	Go to “Unsupported toner cartridge service check” on page 163.
32.14	Unsupported imaging unit	Go to “Unsupported imaging unit service check” on page 164.
32.16	Unsupported cartridge	Go to “Unsupported toner cartridge service check” on page 163.
32.17	Unsupported imaging unit	Go to “Unsupported imaging unit service check” on page 164.
32.19	Unsupported cartridge	Go to “Unsupported toner cartridge service check” on page 163.
32.20	Unsupported imaging unit	Go to “Unsupported imaging unit service check” on page 164.
32.22	Unsupported cartridge	Go to “Unsupported toner cartridge service check” on page 163.
32.23	Unsupported imaging unit	Go to “Unsupported imaging unit service check” on page 164.
32.25	Unsupported cartridge	Go to “Unsupported toner cartridge service check” on page 163.
32.26	Unsupported imaging unit	Go to “Unsupported imaging unit service check” on page 164.
32.28	Unsupported cartridge	Go to “Unsupported toner cartridge service check” on page 163.
32.29	Unsupported imaging unit	Go to “Unsupported imaging unit service check” on page 164.
32.31	Unsupported cartridge	Go to “Unsupported toner cartridge service check” on page 163.
32.32	Unsupported imaging unit	Go to “Unsupported imaging unit service check” on page 164.
32.34	Unsupported cartridge	Go to “Unsupported toner cartridge service check” on page 163.
32.35	Unsupported imaging unit	Go to “Unsupported imaging unit service check” on page 164.

Error code	Description	Action
32.37	Unsupported cartridge	Go to “Unsupported toner cartridge service check” on page 163.
32.38	Unsupported imaging unit	Go to “Unsupported imaging unit service check” on page 164.
33.01	Unsupported cartridge	Go to “Unsupported toner cartridge service check” on page 163.
33.02	Unsupported imaging unit	Go to “Unsupported imaging unit service check” on page 164.
35	Res save off deficient memory	Go to “Insufficient memory service check” on page 167.
37	Insufficient collation area	Go to “Insufficient memory service check” on page 167.
38	Memory full	Go to “Insufficient memory service check” on page 167.
41.01	Imaging unit/cartridge mismatch	Go to “Supplies mismatch service check” on page 166.
41.10	Cartridge/imaging unit mismatch	Go to “Supplies mismatch service check” on page 166.
42	Printer/cartridge region mismatch	Go to “Printer/cartridge mismatch service check” on page 164.
52	Flash full	Go to “Flash full service check” on page 167.
54	Network error	Go to “Network service check” on page 231.
61	The hard disk is defective	Go to “Hard disk failure service check” on page 169
62	The hard disk is full	
80	Maintenance kit	Go to “Maintenance kit service check” on page 167.
84	Imaging unit low	Go to “Imaging unit low service check” on page 168.
88	Toner cartridge low	Go to “Toner cartridge low service check” on page 168.

Unresponsive toner cartridge service check

Action	Yes	No
<p>Step 1</p> <p>a Check if the toner cartridge is a supported and genuine Lexmark supply. If not, then replace it.</p> <p>b Make sure that the toner cartridge is properly installed.</p> <p>c Check the toner cartridge, toner cartridge button, and cartridge plunger for damage. Replace if necessary.</p> <p>d Make sure that the latest firmware is installed.</p> <p>Does the problem remain?</p>	Go to step 2.	The problem is solved.
<p>Step 2</p> <p>Check the cable JARW1 for proper connection to the controller board.</p> <p>Is it properly connected?</p>	Go to step 3.	Reseat the cable.
<p>Step 3</p> <p>Check the toner cartridge smart chip contact for damaged pins.</p> <p>Is it free of damage?</p>	Replace the controller board. See “Controller board removal” on page 320.	Replace the toner cartridge smart chip contact. See “Toner cartridge smart chip contact removal” on page 324.

Unsupported toner cartridge service check

Action	Yes	No
<p>Step 1</p> <p>a Check if the toner cartridge is a supported and genuine Lexmark supply. If not, then replace it.</p> <p>b Make sure that the toner cartridge is properly installed.</p> <p>c Check the toner cartridge, toner cartridge button, and cartridge plunger for damage. Replace if necessary.</p> <p>d Make sure that the latest firmware is installed.</p> <p>Does the problem remain?</p>	Go to step 2.	The problem is solved.
<p>Step 2</p> <p>If this error occurred after replacing the controller board, then restore the printer configuration. See “Restoring the printer configuration after replacing the controller board” on page 279.</p> <p>Does the problem remain?</p>	Contact the next level of support.	The problem is solved.

Printer/cartridge mismatch service check

Action	Yes	No
<p>Step 1</p> <p>a Make sure that the printer and toner cartridge belong to the same country or region. If the printer comes from a different country or region, then contact the next level of support to reset the printer.</p> <p>b Check if the toner cartridge is a supported and genuine Lexmark supply. If not, then replace it.</p> <p>c Make sure that the latest firmware is installed.</p> <p>Does the problem remain?</p>	Go to step 2.	The problem is solved.
<p>Step 2</p> <p>If this error occurred after replacing the controller board, then restore the printer configuration. See “Restoring the printer configuration after replacing the controller board” on page 279.</p> <p>Does the problem remain?</p>	Contact the next level of support.	The problem is solved.

Unsupported imaging unit service check

Action	Yes	No
<p>Step 1</p> <p>a Check if the imaging unit is a supported and genuine Lexmark supply. If not, then replace it.</p> <p>b Make sure that the imaging unit is properly installed.</p> <p>c Make sure that the latest firmware is installed.</p> <p>Does the problem remain?</p>	Go to step 2.	The problem is solved.
<p>Step 2</p> <p>If this error occurred after replacing the controller board, then restore the printer configuration. See “Restoring the printer configuration after replacing the controller board” on page 279.</p> <p>Does the problem remain?</p>	Contact the next level of support.	The problem is solved.

Imaging unit smart chip contact service check

Action	Yes	No
<p>Step 1</p> <p>a Check if the imaging unit is a supported and genuine Lexmark supply. If not, then replace it.</p> <p>b Make sure that the imaging unit is properly installed.</p> <p>Does the problem remain?</p>	Go to step 2.	The problem is solved.
<p>Step 2</p> <p>Check the cable JARW2 for proper connection to the controller board.</p> <p>Is it properly connected?</p>	Go to step 3.	Reseat the cables.
<p>Step 3</p> <p>Check the imaging unit smart chip contact for damaged pins.</p> <p>Is it free of damage?</p>	Replace the controller board. See “Controller board removal” on page 320.	Replace the printer.

Toner smart chip compatibility service check

Action	Yes	No
<p>Step 1</p> <p>Check if the toner cartridge is a supported and genuine Lexmark supply. If not, then replace it.</p> <p>Does the error remain?</p>	Go to step 2.	The problem is solved.
<p>Step 2</p> <p>Update the firmware.</p> <p>Note: Contact the next level of support for the correct firmware level.</p> <p>Does the error remain?</p>	Contact the next level of support.	The problem is solved.

Imaging chip compatibility service check

Action	Yes	No
<p>Step 1 Check if the imaging unit is a supported and genuine Lexmark supply. If not, then replace it.</p> <p>Does the error remain?</p>	Go to step 2.	The problem is solved.
<p>Step 2 Update the firmware.</p> <p>Note: Contact the next level of support for the correct firmware level.</p> <p>Does the error remain?</p>	Contact the next level of support.	The problem is solved.

Supplies mismatch service check

Action	Yes	No
<p>Step 1</p> <p>a Check if the toner cartridge and imaging unit are supported and genuine Lexmark supplies. If not, then replace the supplies.</p> <p>b Make sure that the supplies are compatible.</p> <p>Note: Do not install a MICR cartridge with a non-MICR imaging unit or vice versa.</p> <p>c Make sure that the latest firmware is installed.</p> <p>Does the problem remain?</p>	Go to step 2.	The problem is solved.
<p>Step 2 If this error occurred after replacing the controller board, then restore the printer configuration. See “Restoring the printer configuration after replacing the controller board” on page 279.</p> <p>Does the problem remain?</p>	Contact the next level of support.	The problem is solved.

Flash full service check

Action	Yes	No
<p>Step 1 Format the flash memory. Navigate to Settings > Print Settings > Utilities, then select Format Flash.</p> <p>Does the error remain?</p>	Go to step 2.	The problem is solved.
<p>Step 2 Remove the installed memory, and then POR the machine.</p> <p>Does the error remain?</p>	Go to step 3.	Replace the memory card.
<p>Step 3 Replace the controller board. See “Controller board removal” on page 320.</p> <p>Does the error remain?</p>	Contact the next level of support.	The problem is solved.

Maintenance kit service check

Action	Yes	No
<p>Replace the maintenance kit and reset the Maintenance counter.</p> <p>Does the error remain?</p>	Contact the next level of support.	The problem is solved.

Insufficient memory service check

Action	Yes	No
<p>Step 1 Disable the Resource save feature: Settings > Print Settings > Setup Menu > Resource Save > Off</p> <p>Does the problem remain?</p>	Go to step 2.	The problem is solved.
<p>Step 2 Check the memory card for proper installation.</p> <p>Is it properly installed?</p>	Go to step 3.	Reseat the memory card.

Action	Yes	No
<p>Step 3</p> <p>a Print the Menu settings page: Settings > Reports > Menu Settings Page</p> <p>b POR into the Configuration menu and reset the printer's settings to factory default: Configuration Menu > Factory Defaults > Restore Base</p> <p>c Remove the memory card.</p> <p>d Restart the printer.</p> <p>Does the error remain?</p>	<p>Replace the controller board. See “Controller board removal” on page 320.</p>	<p>Replace the memory card.</p>

Imaging unit low service check

Action	Yes	No
<p>Step 1</p> <p>Replace the imaging unit.</p> <p>Does the problem remain?</p>	<p>Go to step 2.</p>	<p>The problem is solved.</p>
<p>Step 2</p> <p>a Make sure the imaging unit smart chip contact cable is properly connected to the controller board.</p> <p>b Make sure the contacts are free of debris.</p> <p>Does the problem remain?</p>	<p>Go to step 3.</p>	<p>The problem is solved.</p>
<p>Step 3</p> <p>Check the contacts for damaged pins.</p> <p>Are they free of damage?</p>	<p>Contact the next level of support.</p>	<p>Replace the printer.</p>

Toner cartridge low service check

Action	Yes	No
<p>Step 1</p> <p>Replace the toner cartridge.</p> <p>Does the problem remain?</p>	<p>Go to step 2.</p>	<p>The problem is solved.</p>
<p>Step 2</p> <p>a Make sure the toner cartridge smart chip contact cable JARW1 is properly connected to the controller board.</p> <p>b Make sure the contacts are free of debris.</p> <p>Does the problem remain?</p>	<p>Go to step 3.</p>	<p>The problem is solved.</p>

Action	Yes	No
<p>Step 3</p> <p>Check the contacts for damaged pins.</p> <p>Are they free of damage?</p>	Contact the next level of support.	Replace the toner cartridge smart chip contact. See “Toner cartridge smart chip contact removal” on page 324.

Hard disk failure service check

Action	Yes	No
<p>Step 1</p> <p>Delete unnecessary files.</p> <p>a From the home screen, navigate to Settings > Device > Maintenance > Out-of-Service Erase > Erase Hard Disk > Sanitize all information on hard disk.</p> <p>b Select Erase downloads (Erase all macros, fonts, PFOs, etc), Erase buffered jobs, and Erase held jobs > All held jobs.</p> <p>c Touch Erase.</p> <p>Does the problem remain?</p>	Go to step 2.	The problem is solved.
<p>Step 2</p> <p>Make sure that the printer is using the latest firmware version.</p> <p>Does the problem remain?</p>	Go to step 3.	The problem is solved.
<p>Step 3</p> <p>a Make sure that the hard disk cable is properly installed.</p> <p>b Check the cable for damage, and replace if necessary.</p> <p>Does the problem remain?</p>	Go to step 4.	The problem is solved.
<p>Step 4</p> <p>a Make sure that the hard disk is properly installed.</p> <p>b Check the hard disk for damage, and replace if necessary.</p> <p>Does the problem remain?</p>	Go to step 5.	The problem is solved.
<p>Step 5</p> <p>Check the controller board pins for damage.</p> <p>Are the pins free of damage?</p>	Contact the next level of support.	Go to step 6.
<p>Step 6</p> <p>Replace the controller board. See “Controller board removal” on page 320.</p> <p>Does the problem remain?</p>	Contact the next level of support.	The problem is solved.

Printer hardware errors

- “111 errors” on page 170
- “121 errors” on page 174
- “126 errors” on page 176
- “132 errors” on page 177
- “133 errors” on page 178
- “140 errors” on page 179
- “146 errors” on page 180
- “155 errors” on page 181
- “171 errors” on page 182
- “Procedure before starting the 9yy service checks” on page 183
- “900 errors” on page 185
- “912 errors” on page 188
- “94y errors” on page 189
- “950–958 errors” on page 189
- “959 errors” on page 192
- “96y errors” on page 193
- “97y errors” on page 194
- “98y errors” on page 195
- “99y errors” on page 196

111 errors

111 error messages

Notes:

- Some error messages are applicable only to printer models with a polygon LSU (laser scanning unit).
- If the sixth digit character assigned to the serial number of the printer is in the P–Z range, then the printer is installed with a polygon LSU (example: 4514 2ZHH 007CR).

Error code	Description	Action	
111.00	Pel clock check failed.	Go to “Laser scanning unit (LSU) service check” on page 173.	
111.01	Downlevel ASIC detected.		
111.20	Mirror motor lock is asserted before the motor is turned on. Note: This error is applicable only to printer models installed with a polygon LSU.		
111.30	Failed to identify the printhead. Note: This error is applicable only to printer models installed with a polygon LSU.		
111.31	Printhead never delivered HSYNCs.		
111.32	Printhead lost HSYNCs.		
111.33	Printhead lost HSYNCs during servo. Note: This error is applicable only to printer models installed with a polygon LSU.		
111.34	Mirror motor lost lock. Note: This is applicable only to printer models installed with a polygon LSU.		Go to “Laser scanning unit (LSU) service check” on page 173.
111.35	Mirror motor was never locked first. Note: This error is applicable only to printer models installed with a polygon LSU.		
111.36	Mirror motor lock was never stabilized. Note: This error is applicable only to printer models installed with a polygon LSU.		
111.37	Page reached input sensor but the mirror motor was not locked. Note: This error is applicable only to printer models installed with a polygon LSU.		
111.38	Page reached input sensor but the printhead startup was not completed. Note: This error is applicable only to printer models installed with a polygon LSU.		

Error code	Description	Action	
111.40	Wrong printhead installed.	Go to “Laser scanning unit (LSU) service check” on page 173.	
111.50	Open-loop printhead error, open-loop sweep state.		
111.51	Open-loop printhead error, open-loop sweep state.		
111.52	Open-loop printhead error, check prelim amp state.		
111.53	Open-loop printhead error, enable amp Kp state.		
111.54	Closed-loop printhead error, amp Kp failed to converge.		
111.55	Closed-loop printhead error while waiting for amp Kp to converge.		
111.56	Closed-loop printhead error, amp Ki failed to converge.		
111.57	Closed-loop printhead error while waiting for amp Ki to converge.		
111.58	Closed-loop printhead error, load scan regs state.		
111.59	Closed-loop printhead error, forward and reverse capture times differ by too much.		
111.60	Closed-loop printhead sweep error, check sweep accuracy state.		Go to “Laser scanning unit (LSU) service check” on page 173.
111.61	Printhead drive control out of range due to an external event beyond what the control is designed to handle.		
111.62	Closed-loop printhead error, off-resonant PI effort state.		
111.63	Timed out on POR sweep.		
111.64	Attempted to exceed open loop drive limits.		
111.65			
111.66	Failed alignment of printhead.		
111.67	Attempted to exceed open loop drive limits.		
111.68	Too many fake HSYNCs while aligning printhead.		
111.69	Attempted to exceed open loop drive limits.		

Laser scanning unit (LSU) service check

Action	Yes	No
<p>Step 1</p> <p>Make sure that the LSU and controller board are compatible.</p> <ul style="list-style-type: none"> Check the serial number of the printer to determine whether the LSU is galvo or polygon. The LSU is galvo if the sixth digit character assigned is in the 0–9 or B–N range (example: 4514 20HH 007CR). It is polygon if the sixth digit character assigned is in the P–Z range (example: 4514 2ZHH 007CR). <p>Note: Galvo and polygon LSU parts are not interchangeable.</p> <ul style="list-style-type: none"> Check the color of the controller board. For galvo LSU, the color of the compatible controller board is green. For polygon LSU, the color is blue. <p>Are the LSU and controller board compatible?</p>	Go to step 3.	Go to step 2.
<p>Step 2</p> <p>Replace the LSU or controller board with a compatible one.</p> <p>Installation note: Mechanical and electronic LSU adjustments are required to complete the installation of the LSU. See “Printhead assembly adjustments” on page 299.</p> <p>Does the problem remain?</p>	Go to step 3.	The problem is solved.
<p>Step 3</p> <p>Reseat the cables and connector between the LSU and controller board.</p> <p>Does the problem remain?</p>	Go to step 4.	The problem is solved.
<p>Step 4</p> <p>Check the cables for damages, and replace if necessary.</p> <p>Does the problem remain?</p>	Go to step 5.	The problem is solved.
<p>Step 5</p> <p>Check the LSU for proper installation.</p> <ol style="list-style-type: none"> POR into the Diagnostics menu, and then perform a feed test: Diagnostics Menu > Input Tray Test > Feed Test > select a tray Check the display to determine whether the test is successful. If the test fails, then perform the service check to resolve the error code shown. <p>Does the problem remain?</p>	Go to step 6.	The problem is solved.

Action	Yes	No
<p>Step 6 Check the LSU for damages, and replace if necessary. Installation note: Mechanical and electronic LSU adjustments are required to complete the installation of the LSU. See “Printhead assembly adjustments” on page 299.</p> <p>Does the problem remain?</p>	Go to step 7.	The problem is solved.
<p>Step 7 Check the LSU and controller board connector for damaged or bent pins. Replace the part with damaged pins.</p> <p>Does the problem remain?</p>	Go to step 8.	The problem is solved.
<p>Step 8 Replace the controller board.</p> <p>Does the problem remain?</p>	Contact the next level of support.	The problem is solved.

121 errors

121 error messages

Error code	Description	Action
121.07	Fuser has been on for more than allowed after a gap blowout, and the temperature is still too cold.	Go to “Fuser service check” on page 175 .
121.08	Fuser was under temp when page was in fuser.	
121.20	Fuser undertemp during steady state control. Can occur in printing or standby modes.	
121.22	Fuser did not warm enough to start line voltage detection.	
121.23	Fuser took too long to heat to line detection temp.	
121.24	Fuser never reached detection temperature.	
121.25	After line voltage detection, control did not roll over to steady state control in time.	
121.26	Failed to reach temperature during warm up.	
121.28	Failed to reach EP warm up temperature in time.	
121.29	Fuser failed to reach pre-heat temperature for motor start during warm up.	

Error code	Description	Action
121.30	Fuser failed to reach printing temperature by the time a page reached the fuser.	Go to “Fuser service check” on page 175 .
121.31	Fuser is too hot. Global temperature check.	
121.32	Open fuser main thermistor.	
121.33	Open fuser edge thermistor.	
121.34	Open fuser backup roll thermistor.	
121.35	Attempting to POR after receiving a 121.34.	
121.36	Fuser did not heat to allow compression jog.	
121.37	Fuser heated faster than allowed during line voltage detection.	

Fuser service check

Note: A 121.32 fuser error may occur if the ambient temperature is below the freezing point. Printers are optimized to operate in an environment where temperature is between 60 and 90°F and relative humidity is between 8 to 80%.

Action	Yes	No
<p>Step 1</p> <p>a Restore the engine settings to their defaults: Diagnostics Menu > Printer Setup > Defaults</p> <p>b Restore the EP setup settings to their defaults: Diagnostics Menu > EP Setup > Defaults</p> <p>Does the problem remain?</p>	Go to step 2.	The problem is solved.
<p>Step 2</p> <ul style="list-style-type: none"> Check the fuser cables JTHERM1 and JEXIT for proper connection to the controller board. Check the cable PCN5 for proper connection to the power supply. <p>Are they properly connected?</p>	Go to step 3.	Reseat the cables.
<p>Step 3</p> <p>Are the cables JTHERM1, JEXIT and PCN5 free of damage?</p>	Go to step 4.	Replace the fuser. See “Fuser removal” on page 386 .

Action	Yes	No
<p>Step 4</p> <p>a Turn off the printer.</p> <p>b Remove the rear door and cover.</p> <p>c Disconnect the fuser cable connected to PCN5 of the power supply.</p> <p>d Check for approximate correct resistance on the fuser cable:</p> <ul style="list-style-type: none"> • 220V fuser—43 ohms • 110V fuser—10 ohms • 100V fuser—8 ohms <p>Is the resistance equal to any of the above values?</p>	<p>Perform an LVPS service check. See “LVPS service check” on page 176.</p>	<p>Replace the fuser. See “Fuser removal” on page 386.</p>
<p>Step 5</p> <p>Check the fuser rollers, belts and gears for damage and debris.</p> <p>Are they free of damage and debris?</p>	<p>Perform a cooling fan service check and LVPS service check. See “Cooling fan service check” on page 183 and “LVPS service check” on page 176.</p>	<p>Replace the fuser. See “Fuser removal” on page 386.</p>

126 errors

126 error messages

Error code	Description	Action
126.01	Line frequency outside operating range of device.	Go to “LVPS service check” on page 176.
126.02	No line frequency detected.	

LVPS service check

Action	Yes	No
<p>Step 1</p> <p>a Check the power cord for continuity. Replace if necessary.</p> <p>b Make sure the nominal voltage source is within specification. See “Electrical specifications” on page 523.</p> <p>Does the error remain?</p>	<p>Go to step 2.</p>	<p>The problem is solved.</p>
<p>Step 2</p> <p>Check if the power supply cable is properly connected to the controller board.</p> <p>Is it properly connected?</p>	<p>Go to step 3.</p>	<p>Reseat the cables.</p>

Action	Yes	No
<p>Step 3</p> <p>a Turn off the printer.</p> <p>b Remove the power cord.</p> <p>c Measure the resistance between terminals A and D of the power supply socket.</p> <p>Is the resistance approximately 30 ohms?</p>	Contact your next level of support.	Replace the LVPS. See “Power supply removal” on page 361.

132 errors

132 error messages

Error code	Description	Action
132.01	TDS baseline too low.	Go to “Toner density sensor service check” on page 177.
132.02	TDS baseline too high.	
132.03	TDS baseline excessive range.	
132.16	TDS calibration at maximum.	
132.17	TDS calibration too low.	
132.18	TDS calibration too close to baseline.	
132.32	PC drum measurement too high.	
132.33	PC drum measurement too different from calibration.	
132.34	PC drum measurement too close to baseline.	

Toner density sensor service check

Action	Yes	No
<p>Step 1</p> <p>Remove the transfer roll, and then check for loose toner blocking the toner density sensor.</p> <p>Is it free of loose toner?</p>	Go to step 2.	Clean the sensor.
<p>Step 2</p> <p>Check the TDS for proper operation:</p> <p>a Lower the ACM assembly.</p> <p>b Move the toner density sensor wiper from left to right.</p> <p>Does it move freely?</p>	Go to step 3.	Reinstall the wiper properly. If it still cannot move freely, then replace the toner density sensor. See “Sensor (toner density) and media present sensor flag removal” on page 374.

Action	Yes	No
Step 3 Check the cable JTDS for proper connection. Is it properly connected?	Go to step 4.	Reseat the cable.
Step 4 Check the cable JTDS for damage and pinch points. Is it free of damage?	Replace the controller board. See “Controller board removal” on page 320.	Replace the toner density sensor. See “Sensor (toner density) and media present sensor flag removal” on page 374.

133 errors

133 error messages

Error code	Description	Action
133.05	CTLS reading above maximum expected value.	Go to “Unresponsive imaging unit service check” on page 178.
133.06	CTLS reading below minimum expected value.	
133.08	Excessive CTLS noise.	

Unresponsive imaging unit service check

Action	Yes	No
Step 1 a Check if the imaging unit is a supported and genuine Lexmark supply. If not, then replace it. b Make sure that the imaging unit is properly installed. c Make sure that the latest firmware is installed. Does the problem remain?	Go to step 2.	The problem is solved.
Step 2 Check the imaging unit contacts and spring for proper installation or damage. Are the contacts and spring properly installed and damaged?	Go to step 3.	Go to step 5.
Step 3 Check if the imaging unit contacts and spring are beyond repair. Are the contacts and spring beyond repair?	Contact the next level of support.	Go to step 4.

Action	Yes	No
Step 4 Straighten the imaging unit contacts and install the spring properly. Does the problem remain?	Go to step 5.	The problem is solved.
Step 5 Clean the CTLS. Does the problem remain?	Go to step 6.	The problem is solved.
Step 6 <ul style="list-style-type: none"> • Check the cable PCN3 for proper connection to the power supply. • Check the CTLS cable for proper connection to the controller board. Are they properly connected?	Go to step 7.	Reseat the cables.
Step 7 Check the cable PCN3 and CTLS cable for damage. Are they free of damage?	Replace the controller board. See “Controller board removal” on page 320.	Contact the next level of support.

140 errors

140 error messages

Error code	Description	Action
140.10	Transport motor halls not detected.	Go to “Main drive gearbox service check” on page 180.
140.20	Transport motor took too long to stop.	
140.30	Transport motor unable to lock (before motor ID).	
140.40	Transport motor overspeed detected.	
140.60	Transport motor unable to lock (after motor ID).	
140.70	Transport motor out of lock detected.	
140.80	Transport motor excessive PWM or temperature.	

Main drive gearbox service check

Action	Yes	No
Step 1 Remove the main drive gearbox and check for any debris. Is it free of debris?	Go to step 2.	Remove the debris.
Step 2 Check the gears of main drive gearbox for wear or damage. Are they free of wear or damage?	Go to step 3.	Replace the main drive gearbox. See “Main drive gearbox removal” on page 304.
Step 3 Check the main drive motor for proper operation: <ul style="list-style-type: none"> a Remove the main drive gearbox. <ul style="list-style-type: none"> Note: Do not disconnect the main drive gearbox cable. b POR into the Diagnostics menu and perform a feed test: <ul style="list-style-type: none"> Diagnostics Menu > Input Tray Tests > Feed Test > Select any input source c Check if the main drive motor rotates when doing the feed test. Does it rotate when doing the feed test?	Go to “LVPS service check” on page 176.	Replace the main drive gearbox. See “Main drive gearbox removal” on page 304.

146 errors

146 error messages

Error code	Description	Action
146.00	Autocompensator Pick/Lift Motor—Encoder Never Detected in tray 1.	Go to “Tray 1 pick/lift motor gearbox service check” on page 180.

Tray 1 pick/lift motor gearbox service check

Action	Yes	No
Step 1 <ul style="list-style-type: none"> a Remove Tray 1. b Check the lift plate and gears for proper operation by moving the metal plate. Do the lift plate and gears move freely, and are they free of wear or damage?	Go to step 2.	Replace the tray insert.

Action	Yes	No
<p>Step 2</p> <p>Check the pick/lift motor gearbox for the following:</p> <ul style="list-style-type: none"> • Gear tooth breakage • Freedom of rotation <p>Is it free of wear or damage?</p>	Go to step 3.	Replace the pick/lift motor gearbox. See “Pick/lift motor gearbox removal” on page 371.
<p>Step 3</p> <p>Check the cable JLIFT1 on the controller board.</p> <p>Is it properly connected and free of damage?</p>	Go to step 4.	Replace the pick/lift motor gearbox. See “Pick/lift motor gearbox removal” on page 371.
<p>Step 4</p> <p>Replace the controller board.</p> <p>Does this fix the problem?</p>	The problem is solved.	Contact the next level of support.

155 errors

155 error messages

Error code	Description	Action
155.00	No encoder received from auger motor.	Go to “Cartridge gearbox service check” on page 181.

Cartridge gearbox service check

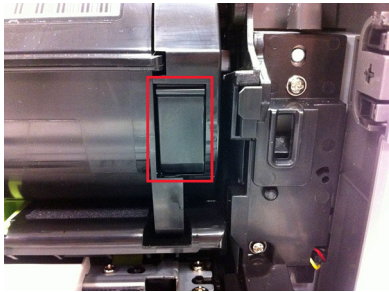
Action	Yes	No
<p>Step 1</p> <p>Is the button aligned with the front of the toner cartridge?</p> 	Go to step 2.	Go to step 3.
<p>Step 2</p> <p>a Remove the toner cartridge. b Clear the paper jam.</p> <p>Does the problem remain?</p>	Go to step 5.	The problem is solved.

Action	Yes	No
<p>Step 3</p> <p>a Remove, and then reinstall the toner cartridge. Make sure that it is properly seated.</p> <p>b Check the toner cartridge, toner cartridge button, and cartridge plunger for damage. Replace if necessary.</p> <p>c Make sure that the latest firmware is installed.</p> <p>Does the problem remain?</p>	Go to step 4.	The problem is solved.
<p>Step 4</p> <p>Run a print test.</p> <p>Does the problem remain?</p>	Go to step 5.	The problem is solved.
<p>Step 5</p> <p>Replace the toner cartridge</p> <p>Does the problem remain?</p>	Go to step 6.	The problem is solved.
<p>Step 6</p> <p>Check the gears on the cartridge gearbox for proper rotation and for wear or damage.</p> <p>Does it rotate properly and is it free of wear or damage?</p>	Go to step 7.	Replace the cartridge gearbox. See “Cartridge gearbox removal” on page 312.
<p>Step 7</p> <p>Check the cartridge gearbox cable for proper connection to the controller board.</p> <p>Is it properly connected?</p>	Go to step 8.	Reseat the cable.
<p>Step 8</p> <p>Check the cartridge gearbox cable for damage.</p> <p>Is it free of damage?</p>	Replace the controller board. See “Controller board removal” on page 320.	Replace the cartridge gearbox. See “Cartridge gearbox removal” on page 312.

171 errors

171 error messages

Error code	Description	Action
171.03	Fuser fan error.	Go to “Cooling fan service check” on page 183.
171.04	Fuser fan error.	
171.05	Fuser fan error.	
171.06	Fuser fan error.	
171.07	Fuser fan error.	

Cooling fan service check

Action	Yes	No
<p>Step 1</p> <p>a Make sure that the cable JFAN1 is properly connected to the controller board.</p> <p>b Check if the cooling fan is rotating properly.</p> <p>Is it rotating properly?</p>	Go to step 2.	Replace the cooling fan. See “Cooling fan removal” on page 319.
<p>Step 2</p> <p>a Turn off the printer, and disconnect JFAN1 from the controller board.</p> <p>b Turn on the printer, and measure the voltage across JFAN1.</p> <p>Is the voltage approximately 24 V?</p>	Go to step 3.	Replace the controller board. See “Controller board removal” on page 320.
<p>Step 3</p> <p>Is the fan idle?</p>	Replace the cooling fan. See “Cooling fan removal” on page 319.	The problem is solved.

ACM service check

Action	Yes	No
<p>Step 1</p> <p>Check the pick/lift motor gearbox for proper operation.</p> <p>a POR into the Diagnostics menu and perform a feed test: Diagnostics Menu > Input Tray Tests > Feed Test > Tray 1</p> <p>b Check if the pick/lift motor gearbox rotates on each pick.</p> <p>Does it rotate during the feed test?</p>	Go to step 2.	Replace the pick/lift motor gearbox. See “Pick/lift motor gearbox removal” on page 371.
<p>Step 2</p> <p>Lower the ACM assembly, and rotate the pick roller toward the front without touching the pick tire.</p> <p>Does it rotate properly?</p>	Replace the controller board. See “Controller board removal” on page 320.	Replace the ACM assembly. See “ACM assembly removal” on page 369.

Procedure before starting the 9yy service checks

You will need to retrieve certain information. This information will aid your next level of support in diagnosing the problem before replacing the controller board.

Warning—Potential Damage: Do not replace the controller board unless directed by your next level of support.

- 1 Collect the history information and firmware logs (Fwdebug and logs.tar.gz) from the SE menu.
- 2 Collect the settings from the menu settings page.

3 Collect information from the user.

Note: Not all of the items are retrievable from the printer you are working on.

A. Collecting the history information from the SE menu

Note: Make sure that your printer is connected to a network or to a print server.

1 Open a Web browser, type **http://printer_IP_address/se**, and then press **Enter**.

Notes:

- **printer_IP_address** is the TCP/IP address of the printer
- **se** is required to access the printer diagnostic information

2 Click **History Information**, copy all information, and then save it as a text file.

3 E-mail the text file to your next level of support.

B. Collecting the firmware logs (Fwdebug and logs.tar.gz) from the SE menu

Notes:

- Make sure that your printer is connected to a network or to a print server.
- Some printers are designed to restart automatically after a 9yy error. On these printers, you can retrieve the secondary crash code information using the SE menu.
- Fwdebugs can also be referred to as LBtrace. If FWEdebugs does not appear in the list, then look for LBtrace. Multiple LBtrace logs can appear in the list of links referred to in step 2.

1 Open a Web browser, type **http://printer_IP_address/se**, and then press **Enter**.

2 Click **List Fwdebugs captured during reboots**.

Note: A list of the secondary crash codes retrieved from previous reboots will be generated. If there are Fwdebugs listed, then click **Dump Fwdebug log0**, **Dump Fwdebug log1**, and **Dump Fwdebug log2**. Clicking these links will dump the debug logs to the computer. Take note of the destination folder where the logs are saved.

3 E-mail the logs to your next level of support.

Note: Some printer SE menus give you the option of clicking **Logs Gzip Compressed**. If this option is shown in the menu, then click it and retrieve the compressed log file. Take note of the destination folder where the log file is saved.

C. Collecting the settings from the menu settings page

Note: The menu settings page is different for each printer. For more information see the *User's Guide*. Your next level of support will tell you which page they want to see.

Copying the menu settings page from the Embedded Web Server (EWS)

Note: Make sure that your printer is connected to a network or to a print server.

1 Open a Web browser, type **http://printer_IP_address**, and then press **Enter**.

2 Click Settings, and then select one of the settings pages from the links shown on the page.

3 Copy all the information, and then save it as a text file.

4 E-mail the text file to your next level of support.

Printing the menu settings page

1 From the home screen, navigate to:

Reports > Menu Settings Page

2 Print the menu settings page, and then use Scan to E-mail to send it to your next level of support.

D. Collecting information from the user

Ask the user for information about the following:

- Print job being run
- Operating system being used
- Print driver being used
- Other information on what was happening when the 9yy error occurred

900 errors

900 error messages

Error code	Description	Action
900.xx	RIP firmware errors	Go to “900 error service check” on page 185.

900 error service check

Action	Yes	No
<p>Step 1</p> <p>a Perform a POR.</p> <p>b Check if a 900.xx error code appears on the display.</p> <p>Does a 900.xx error code appear?</p>	Go to step 4.	Go to step 2.
<p>Step 2</p> <p>Check if another type of error code appears instead of the 900.xx error code.</p> <p>Does a different error code appear?</p>	Go to step 3.	Go to step 4.
<p>Step 3</p> <p>See the error code and its service instructions in the printer <i>Service Manual</i>.</p> <p>Does the problem remain?</p>	Go to step 4.	The problem is solved.

Action	Yes	No
<p>Step 4</p> <p>a Turn off the printer.</p> <p>b At the rear of the printer, disconnect the network cable, USB cable, and fax line.</p> <p>c Turn on the printer.</p> <p>Does the problem remain?</p>	Go to step 12.	Go to step 5.
<p>Step 5</p> <p>a From the control panel, navigate to the Reports menu.</p> <p>b Select Device Statistics and Device Settings.</p> <p>Does the problem remain?</p>	Go to step 12.	Go to step 6.
<p>Step 6</p> <p>Check if the printer has a scanner.</p> <p>Does the printer have a scanner?</p>	Go to step 7.	Go to step 8.
<p>Step 7</p> <p>Using the scanner, perform a one-page copy job in color.</p> <p>Does the problem remain?</p>	Go to step 12.	Go to step 8.
<p>Step 8</p> <p>a Turn off the printer.</p> <p>b At the rear of the printer, connect the network cable, USB cable, and fax line.</p> <p>c Turn on the printer.</p> <p>Does the problem remain?</p>	Go to step 9.	Go to step 10.
<p>Step 9</p> <p>a Start the printer in Invalid engine mode. See “Entering Invalid engine mode” on page 273.</p> <p>b Check if an Invalid Engine Code message appears.</p> <p>Does an Invalid Engine Code message appear?</p>	Go to step 10.	Contact the next level of support.
<p>Step 10</p> <p>Using the Device Settings report that is printed in step 5, check if the firmware level is older than the latest available version.</p> <p>Is the firmware version older, and does the customer agree to update the firmware?</p>	Go to step 11.	Contact the next level of support.
<p>Step 11</p> <p>Update the firmware to the latest version.</p> <p>Does the problem remain?</p>	Go to step 12.	The problem is solved.

Action	Yes	No
<p>Step 12</p> <p>a Turn off the printer.</p> <p>b Make sure that all the cables on the controller board and scanner are properly connected.</p> <p>c Turn on the printer.</p> <p>d From the control panel, navigate to the Reports menu, and then select Device Statistics and Device Settings.</p> <p>e For MFPs, perform a one-page copy and scan job in color.</p> <p>Does the problem remain?</p>	Go to step 13.	The problem is solved.
<p>Step 13</p> <p>Check if a hard disk installed.</p> <p>Is a hard disk installed?</p>	Go to step 14.	Go to step 17.
<p>Step 14</p> <p>a Check for buffered print jobs, and then delete them. See “Hard disk failure service check” on page 169.</p> <p>b Perform a POR.</p> <p>Does the problem remain?</p>	Go to step 15.	The problem is solved.
<p>Step 15</p> <p>a Turn off the printer.</p> <p>b Uninstall the hard disk drive.</p> <p>c Perform a POR.</p> <p>Does the problem remain?</p>	Go to step 17.	Go to step 16.
<p>Step 16</p> <p>Replace the hard disk.</p> <p>Does the problem remain?</p>	Go to step 17.	The problem is solved.
<p>Step 17</p> <p>Check if the printer has any of the following components installed:</p> <ul style="list-style-type: none"> • Memory options • Fax card • Modem • Wireless and network option cards <p>Is any of the components installed?</p>	Go to step 18.	Go to step 21.

Action	Yes	No
<p>Step 18</p> <p>a Turn off the printer.</p> <p>b Remove all the installed components.</p> <p>c Turn on the printer.</p> <p>Does the problem remain?</p>	Go to step 21.	Go to step 19.
<p>Step 19</p> <p>a Turn off the printer.</p> <p>b Install the following components one at a time:</p> <ul style="list-style-type: none"> • Memory options • Fax card • Modem • Wireless and network option cards <p>Note: Make sure to perform a POR after installing each component.</p> <p>Does the problem remain?</p>	Go to step 20.	The problem is solved.
<p>Step 20</p> <p>a Turn off the printer.</p> <p>b Replace the components that caused the error.</p> <p>c Turn on the printer.</p> <p>Does the problem remain?</p>	Go to step 21.	The problem is solved.
<p>Step 21</p> <p>Replace the controller board. See “Controller board removal” on page 320.</p> <p>Does the problem remain?</p>	Contact the next level of support.	The problem is solved.

912 errors

912 error messages

Error code	Description	Action
912.xx	Unrecoverable Engine firmware error POR the machine. If the error re-occurs, then update the firmware. If the error continues occurring, then check the controller board.	Go to “Controller board service check” on page 226 .

94y errors

94y error messages

Error code	Description	Action
940.xx	RIP to engine communication failure—the zero crossing signal used for fuser control in the low voltage (LV) power supply has failed, or the wrong low voltage power supply has been installed.	Go to “LVPS service check” on page 176.
948.xx	Failed engine card—pel clock check failed. Replace the controller board.	Go to “Controller board removal” on page 320.
949.xx	Failed engine card—delay line calibration failure. Replace the controller board.	

950–958 errors

950–958 error messages

Error code	Description	Action
950.xx	NVRAM mismatch failure—mismatch between controller board EEPROM and control panel mirror. ".xx" codes: <ul style="list-style-type: none"> • 00-29— mismatch between system and mirror • 30-60—mismatch between secure and system 	Go to “NVRAM mismatch failure service check” on page 190.
952.xx	A recoverable NVRAM Cyclic Redundancy Check (CRC) error occurred—n is the offset at which the error occurred.	Go to “NVRAM cyclic redundancy service check” on page 191.

Error code	Description	Action
953.xx	NVRAM chip failure with mirror part Replace the controller board.	Go to “Controller board removal” on page 320.
954.xx	NVRAM chip failure with system part Replace the controller board.	
955.xx	The Code ROM or NAND flash failed the Cyclic Redundancy Check (CRC) or the NAND experienced an uncorrectable multi-bit failure. Replace the controller board.	
956.xx	RIP card failure—processor failure Replace the controller board.	
956.01	Processor temperature is over the limit. Replace the controller board.	
957.xx	RIP card failure—ASIC failure Replace the controller board.	
958.xx	Controller Board NAND Failure—printer has performed more than 100 shift and reflash operations as a result of ECC bit corrections. Replace the controller board.	

NVRAM mismatch failure service check

Warning—Potential Damage: When replacing any of the following components:

- Control panel assembly
- Controller board assembly

Replace only one component at a time. Replace the required component and perform a POR before replacing a second component listed above. If this procedure is not followed, the printer will be rendered inoperable. Never replace two or more of the components listed above without a POR after installing each one or the printer will be rendered inoperable.

Warning—Potential Damage: These components can be used as a method of troubleshooting as long as the machine is booted into diagnostic mode or is operating in diagnostic mode. Once a component has been installed in a machine and powered up into user mode, it cannot be used in another machine. It must be returned to the manufacturer.

Action	Yes	No
Step 1 Check the control panel assembly. Was the control panel assembly recently replaced?	Go to step 3.	Go to step 2.
Step 2 Check the controller board assembly. Was the controller board assembly recently replaced?	Go to step 4.	Contact next level of support.

Action	Yes	No
<p>Step 3</p> <p>Replace the current control panel assembly with the original control panel assembly. Go to “Control panel assembly removal” on page 336.</p> <p>Does the error remain?</p>	Go to step 5.	The problem is solved.
<p>Step 4</p> <p>Replace the current controller board assembly with the original controller board assembly. Go to “Controller board removal” on page 320.</p> <p>Does the problem continue?</p>	Go to step 6.	The problem is solved.
<p>Step 5</p> <p>Replace the original control panel assembly with a new and not previously installed control panel assembly.</p> <p>Does the error continue?</p>	Contact the next level of support.	The problem is solved.
<p>Step 6</p> <p>Replace the original control panel assembly with a new and not previously installed control panel door assembly.</p> <p>Does the error continue?</p>	Contact the next level of support.	The problem is solved.

NVRAM cyclic redundancy service check

Action	Yes	No
<p>POR the printer.</p> <p>Does the error remain?</p>	Contact the next level of support.	The problem is solved.

959 errors

959 error messages

Error code	Description	Action
959.01	Controller verification failure of pensive boot code	Go to “Invalid firmware/controller board service check” on page 193.
959.02	Failure to authenticate Signature Verification Code	
959.03	Signature Verification Code failed to authenticate a code partition	
959.04	Jump to unverified address	
959.05	Unknown Boot Failure	
959.20	Pensive hardware failure	
959.21	Pensive did not respond to command request	
959.22	Challenge Secret Failure	
959.23	Pensive self test failed during initialization	
959.24	EEPROM Retention Error (Write failure)	
959.25	Insufficient device space during HW prog	
959.26	Incremental counter reset exceeds maximum value	
959.27	Increment count failed due to max value limit	
959.28	Invalid SP Memory Configuration	
959.30	Pensive library flagged an invalid argument(s)	Go to “Invalid firmware/controller board service check” on page 193.
959.31	Pensive library flagged an invalid device address	
959.32	Failure to init physical interface	
959.33	Unknown/unexpected Error	
959.34	System Pensive Bus Busy Error	
959.35	Transmission Error	
959.36	Pensive command is invalid due to unlocked device status	
959.37	Pensive command is invalid due to locked device status	
959.38	Incremental counter id(s) are invalid	
959.39	Invalid NV address	
959.40	Invalid Pensive command	

Invalid firmware/controller board service check

Action	Yes	No
Update the firmware. Note: Contact the next level of support for the correct firmware level. Does the error remain?	Replace the controller board. See “Controller board removal” on page 320 .	The problem is solved.

96y errors

96y error messages

Error code	Description	Action
960.xx	RAM Memory Error—RAM soldered on the card is bad Replace the controller board.	Go to “Controller board removal” on page 320 .
961.xx	RAM Memory Error—optional DRAM is bad	Go to “RAM memory error service check” on page 193 .
964.xx	Download Emulation Cyclic Redundancy Check (CRC) Error—checksum failure detected in the emulation header or emulation file.	Go to “Download emulation cyclic redundancy service check” on page 193 .

RAM memory error service check

Action	Yes	No
Replace the bad memory card. Does the error remain?	Contact the next level of support.	The problem is solved.

Download emulation cyclic redundancy service check

Action	Yes	No
Step 1 Disable the download emulation, and then program the download emulation into the firmware card again. Does the error remain?	Go to step 2.	The problem is solved.
Step 2 Replace the firmware card and download the emulation to the new card. Does the error remain?	Contact the next level of support.	The problem is solved.

97y errors

97y error messages

Error code	Description	Action
975.xx	Network error—Unrecognizable network port.	Go to “Network port error service check” on page 194.
976.xx	Network error—Unrecoverable software error in network port.	
978.xx	Network error—Bad checksum while programming network port.	
979.xx	Network error—Flash parts failed while programming network port.	

Network port error service check

Action	Yes	No
<p>Step 1</p> <p>Check the network cable for proper connection and damage, and replace if necessary.</p> <p>Does the problem remain?</p>	Go to step 2.	The problem is solved.
<p>Step 2</p> <p>Check the controller board network port for proper operation and damage, and replace the controller board if necessary.</p> <p>Does the problem remain?</p>	Contact the next level of support.	The problem is solved.

98y errors

98y error messages

Error code	Description	Action
980.xx	Engine experiencing unreliable communication with the specified device.	Go to “Option communication error service check” on page 195.
981.xx	Engine protocol violation detected by the specified device.	
982.xx	Communications error detected by the specified device. Device can be: <ul style="list-style-type: none"> • Engine, Duplex, Tray [x], Env Feeder • Output Bin [x] (applicable only for single bin devices) • Bins [x] to [y] (applicable only for multiple bin devices) 	
983.xx	Invalid command received by the specified device.	
984.xx	Invalid command parameter received by the specified device.	

Option communication error service check

Action	Yes	No
Step 1 Make sure that the optional hardware is compatible with the printer. Does the problem remain?	Go to step 2.	The problem is solved.
Step 2 Make sure that the firmware of the engine and options are compatible. Are the firmware of the engine and options compatible?	Go to step 4.	Go to step 3.
Step 3 Update the firmware. Does the problem remain?		
Step 4 Make sure that the interconnect cables are properly seated. Does the problem remain?	Go to step 5.	The problem is solved.

Action	Yes	No
<p>Step 5</p> <p>Make sure that both ends of the interconnect cables are properly connected to the controller board and engine options card.</p> <p>Does the problem remain?</p>	Go to step 6.	The problem is solved.
<p>Step 6</p> <p>Check the option for damage, and replace if necessary.</p> <p>Does the problem remain?</p>	Go to step 7.	The problem is solved.
<p>Step 7</p> <p>Check the controller board for damage, and replace if necessary.</p> <p>Does the problem remain?</p>	Contact the next level of support.	The problem is solved.

99y errors

99y error messages

Error code	Description	Action
990.xx	<p>An equipment check condition has occurred in the specified device, but the device is unable to identify the exact component failure. The device can be:</p> <ul style="list-style-type: none"> • Engine, Duplex, Tray [x], Env Feeder • Output Bin [x] (applicable only for single bin devices) • Bins [x] to [y] (applicable only for multiple bin devices) 	Go to “Option communication error service check” on page 195.
991.xx	<p>The specified device has detected an equipment check in its controller board. The device can be:</p> <ul style="list-style-type: none"> • Engine, Duplex, Tray [x], Env Feeder • Output Bin [x] (applicable only for single bin devices) • Bins [x] to [y] (applicable only for multiple bin devices) 	

ADF/Scanner hardware errors

8yy errors

8yy error messages

Error code	Description	Action
840.01	The scanner is disabled and can't be used.	Go to “Scanner disabled error service check” on page 198.
840.02 840.03	The scanner is disabled and can't be used. This message is posted when the MFP PORs. Enter the configuration menu, and reenables the scanner module.	Go to “Scanner disabled error service check” on page 198.
841.xx	Scanner failure—front side image processing ASIC. Invalid configuration or ASIC not found	Image pipeline ASIC. See “CCD service check” on page 199. Also, see “Flatbed home position service check” on page 200.
842.xx	Scanner failure—communications	Go to “CCD service check” on page 199.
843.00	Scanner failure—carriage failed to Home or move to desired position	Go to “Scanner carriage failure service check” on page 201.
843.01	ADF mechanical failure	Go to “ADF service check” on page 201.
843.02	Generic Mechanical failure detected	Go to “ADF service check” on page 201.
843.03	Pick Roller Engage Failure	Go to “ADF service check” on page 201.
843.04	Pick Roller Disengage Failure	Go to “ADF service check” on page 201.
843.05	Carriage overrun	Go to “ADF service check” on page 201.
843.06	ADF nudger	Go to “ADF service check” on page 201.
843.99	Scanner complete timeout error	Go to “ADF service check” on page 201.
845.02	An error has occurred during the initialization process with the flatbed scanner CCD.	Go to “Flatbed scanner CCD initialization error service check” on page 203
849.01	Configuration error—the device had modem installed, but configID indicates it should not.	Go to “Scanner configuration error service check” on page 203.
849.10	Configuration error—the device had HD installed, but configID indicates it should not.	Go to “Scanner configuration error service check” on page 203.

Scanner disabled error service check

Actions	Yes	No
<p>Step 1 POR the machine into Configuration menu > Disable scanner. From there, select Enabled to change the settings to reenable the scanner module and then save the setting. POR the MPF to operating mode. Try running a copy from the ADF and flatbed.</p> <p>Did the 840.xx error reoccur?</p>	Go to step 2.	The problem is solved.
<p>Step 2 Reenter the Configuration mode, and scroll to and select the Disable Scanner menu item.</p> <p>Does the screen display “ADF disabled” or “Auto Disabled”?</p>	Go to step 3.	Go to step 8.
<p>Step 3 Check the ADF cable connections on the ADF relay card and connector JADF1 on the controller board. Also inspect the cable connections JHOME1, JFBM1, JPLEN1, and J30 on the controller board.</p> <p>Are the connections properly connected?</p>	Go to step 5.	Go to step 4.
<p>Step 4 Properly connect the connections on the ADF relay card and controller board. POR the machine into Configuration menu > Disable scanner. From there, select Enabled to change the settings to re-enable the scanner module and then save the setting. POR the MPF to operating mode. Try running a copy from the ADF and flatbed.</p> <p>Did the 840.xx error reoccur?</p>	Go to step 5.	The problem is solved.
<p>Step 5 Check the continuity on the ADF cable.</p> <p>Is there continuity?</p>	Go to step 7.	Go to step 6.
<p>Step 6 Replace the ADF cable. POR the machine into Configuration menu > Disable scanner. From there, select Enabled to change the settings to re-enable the scanner module and then save the setting. POR the MPF to operating mode. Try running a copy from the ADF and flatbed.</p> <p>Did the 840.xx error reoccur?</p>	Go to step 7.	The problem is solved.

Actions	Yes	No
<p>Step 7</p> <p>Replace the ADF unit. See “ADF unit removal” on page 402.</p> <p>POR the machine into Configuration menu > Disable scanner.</p> <p>From there, select Enabled to change the settings to re-enable the scanner module and then save the setting.</p> <p>POR the MPF to operating mode. Try running a copy from the ADF and flatbed.</p> <p>Did the 840.xx error reoccur?</p>	Go to step 8.	The problem is solved.
<p>Step 8</p> <p>Inspect JFBM1, JHS1 and J30 on the controller board.</p> <p>Are they properly connected?</p>	Go to step 10.	Go to step 9.
<p>Step 9</p> <p>Properly connect all the connections.</p> <p>Did the 840.xx error reoccur?</p>	Go to step 10.	The problem is solved.
<p>Step 10</p> <p>Replace the flatbed unit. See “Flatbed assembly removal” on page 412.</p> <p>POR the machine into Configuration menu > Disable scanner.</p> <p>From there, select Enabled to change the settings to re-enable the scanner module and then save the setting.</p> <p>POR the MPF to operating mode. Try running a copy from the ADF and flatbed.</p> <p>Did the 840.xx error reoccur?</p>	Go to step 11.	The problem is solved.
<p>Step 11</p> <p>Replace the controller board. See “Controller board removal” on page 320.</p> <p>Did the 840.xx error reoccur?</p>	Contact second-level support.	The problem is solved.

CCD service check

Actions	Yes	No
<p>Step 1</p> <p>Restart the device, and retry the scan/copy job. Repeat this step with a few copy jobs.</p> <p>Does the error return?</p>	Go to step 2.	No issue.
<p>Step 2</p> <p>Is the CCD ribbon cable properly connected to J30 on the controller board?</p>	Go to step 3.	Properly connect cable to J30.

Actions	Yes	No
<p>Step 3 Replace the flatbed unit. See “Flatbed assembly removal” on page 412.</p> <p>Did this resolve the issue?</p>	The problem is solved.	Replace the controller board. See “Controller board removal” on page 320.

Flatbed home position service check

Actions	Yes	No
<p>Step 1 POR the MFP.</p> <p>Does the CCD move and return to the home position?</p>	The problem is solved.	Go to step 2.
<p>Step 2 Perform the home position sensor test. See “Scanner tests” on page 256.</p> <p>Is the sensor working properly?</p>	Go to step 3.	Go to step 5.
<p>Step 3 Check JFBM1 on the controller for proper connection.</p> <p>Is it connected properly?</p>	Go to step 4.	Properly connect the cable.
<p>Step 4 Check pin 1 in JFBM1 for voltage. The voltage is only present when a flatbed copy job is running. The voltage should measure +24V AC.</p> <p>Is voltage present?</p>	Go to step 5.	Replace the controller board. See “Controller board removal” on page 320.
<p>Step 5 Ensure that the home position cable JHOME1 is connected.</p> <p>Is the cable connected?</p>	Go to step 6.	Properly connect the cable.
<p>Step 6 Check pin 1 in JHOME1 for voltage. The voltage should measure +5V DC. Pin 2 should be GND.</p> <p>Is voltage present and is it correct?</p>	Replace the flatbed. See “Flatbed assembly removal” on page 412.	Replace the controller board. See “Controller board removal” on page 320.

Scanner carriage failure service check

Actions	Yes	No
<p>Step 1 POR the printer, open the scanner cover, and do the following:</p> <ul style="list-style-type: none"> • Check if the scanner carriage moves away, and then back to its home position. • Check if the CCD lamp illuminates. • Check if Ready appears on the control panel. <p>Are the components properly working?</p>	The problem is solved.	Go to step 2.
<p>Step 2 Make sure that the flatbed flat flexible cable is properly connected.</p> <p>Does the problem remain?</p>	Go to step 3.	The problem is solved.
<p>Step 3 Check the flatbed flat flexible cable for damage, and then replace the flatbed assembly if necessary. See “Flatbed assembly removal” on page 412.</p> <p>Does the problem remain?</p>	Go to step 4.	The problem is solved.
<p>Step 4 Replace the controller board. See “Controller board removal” on page 320.</p> <p>Does the problem remain?</p>	Contact the next level of support.	The problem is solved.

ADF service check

Action	Yes	No
<p>Step 1 Check all cables connecting the ADF and flatbed to the controller board.</p> <p>Are they properly connected?</p>	Go to step 3.	Go to step 2.
<p>Step 2 Reconnect the cables to the controller board.</p> <p>Did this fix the problem?</p>	The problem is solved.	Go to step 3.

Action	Yes	No
<p>Step 3</p> <p>a Enter diagnostics mode and navigate to: SCANNER TESTS > Sensor Test Perform the scanner sensor tests.</p> <p>b Navigate to: SCANNER TESTS > Motor Tests Perform the scanner sensor and motor tests.</p> <p>Did any test fail?</p>	Go to step 4.	Go to step 8.
<p>Step 4</p> <p>Did the Flatbed Home Sensor test or Flatbed motor test fail?</p>	Go step 5.	Go to step 6.
<p>Step 5</p> <p>Replace the flatbed. See “Flatbed assembly removal” on page 412.</p> <p>Did this solve the problem?</p>	The problem is solved.	Go to step 6.
<p>Step 6</p> <p>Did the ADF pick motor or feed motor tests fail?</p>	Go to step 7.	Go to step 8.
<p>Step 7</p> <p>Replace the ADF. See “ADF unit removal” on page 402.</p> <p>Did this fix the problem?</p>	The problem is solved.	Go to step 8.
<p>Step 8</p> <p>Replace the power supply. See “Power supply removal” on page 361.</p> <p>Did this fix the problem?</p>	The problem is solved.	Go to step 9.
<p>Step 9</p> <p>Replace the controller board. See “Controller board removal” on page 320.</p> <p>Did this fix the problem?</p>	The problem is solved.	Contact the next level of support.

Flatbed scanner CCD initialization error service check

Action	Yes	No
<p>Step 1</p> <p>Check the flatbed scanner controller board and all connections on the controller board in the printer for proper connectivity.</p> <p>Are the components properly connected?</p>	Go to step 2.	Replace the connections.
<p>Step 2</p> <p>Perform a flatbed scanner test.</p> <p>Does the problem remain?</p>	Replace the flatbed unit. See “Flatbed assembly removal” on page 412.	The problem is resolved.
<p>Step 3</p> <p>Place an undamaged document on the ADF elevator tray and perform a scanner test.</p> <p>Does the problem remain?</p>	Replace the controller board. See “Controller board removal” on page 320.	The problem is resolved.

Scanner configuration error service check

Action	Yes	No
Contact the next level of support. They will give the instructions on how to resolve the error.	N/A	N/A

Scan/fax/copy symptoms

Scan/fax/copy symptoms

Symptom	Action
ADF won't duplex (Duplex ADF only)	Go to “ADF duplex service check” on page 204.
ADF skew	Go to “ADF feed errors service check” on page 205.
Multiple pages feed into ADF	Go to “ADF feed errors service check” on page 205.
Documents wont feed into ADF	Go to “ADF feed errors service check” on page 205.
Scanner makes buzzing noise on startup or during a scan.	Go to “Flatbed home position service check” on page 200.
Document feeds, but jams in ADF.	Go to “ADF paper jam service check” on page 125.
Blank page	Go to “Black or blank page copy service check” on page 206.
Black page	
No dial tone	Go to “Modem/fax card service check” on page 207.

Symptom	Action
Machine dials a number but fails to make a connection with another fax machine.	The other fax machine may be turned off. Ask the fax recipient to check their machine.
Incoming fax has blank spaces or poor quality.	Go to “Blank spaces on incoming fax service check” on page 208.
Invalid fax partition, or fax partition too small.	Go to “Format fax storage” on page 265.
Some words on an incoming fax are stretched.	Go to “Stretched words on incoming fax service check” on page 219.
Faxes fail to transmit.	Go to “Fax transmission service check” on page 209.
Fax reception fails.	Go to “Fax reception service check” on page 211.
Rattling noise coming from the ADF unit.	Go to “ADF rattling noise service check” on page 214.
Scanner fails to scan legal size paper	Go to “Flatbed legal scan service check” on page 213.

ADF duplex service check

Note: This service check should be used if the paper feeds and jams in the ADF. If the paper is not feeding into the ADF see [“ADF feed errors service check” on page 205.](#)

Actions	Yes	No
<p>Step 1 Perform the ADF motor tests to verify that the motors are working properly. See “Motor tests” on page 256.</p> <p>Are the motors operating properly?</p>	Go to step 2.	Go to step 4.
<p>Step 2 Perform the scanner sensor tests. See “Scanner tests” on page 256.</p> <p>Are the sensors working properly?</p>	Go to step 3.	Go to step 4.
<p>Step 3 Check the ADF sensor actuators.</p> <p>Are the actuators dirty or jammed?</p>	Clean the actuators. If any actuators on the ADF are broken, then replace the ADF unit. See “ADF unit removal” on page 402.	Go to step 4.
<p>Step 4 Check all of the connections on the ADF relay card. Are they properly connected?</p>	Go to step 5.	Properly connect all of the connections.

Actions	Yes	No
<p>Step 5</p> <p>Check the ADF cable to ensure that it is properly connected to the ADF relay card, and to the main controller board at JADF1.</p> <p>Is the ADF cable properly connected?</p>	Go to step 6.	Properly connect the ADF cable to its connections.
<p>Step 6</p> <p>Check the ADF cable for continuity. Make sure pin 22 has continuity.</p> <p>Does pin 22 have continuity?</p>	Go to step 7.	Replace the ADF cable. See “ADF cable removal” on page 408 .
<p>Step 7</p> <p>Replace the ADF. See “ADF unit removal” on page 402.</p> <p>Does this fix the situation?</p>	Problem solved.	Replace the controller board. See “Controller board removal” on page 320 .

ADF feed errors service check

Actions	Yes	No
<p>Step 1</p> <p>If the ADF is multi-feeding, check for dirt on the ADF separator pad and ADF separator rollers.</p> <p>Are they dirty?</p>	Clean them with a lint free cloth and isopropyl alcohol.	Replace the separator pad and restraint pad.
<p>Step 2</p> <p>If the paper is skewing when it is fed into the ADF, check the paper guide width.</p> <p>Is it set correctly?</p>	Go to step 3.	Set the paper guides so they contact the edges of the paper.
<p>Step 3</p> <p>If paper is skewing when fed or jamming check to see if the top cover is open or ajar.</p> <p>Is the ADF top cover open or ajar?</p>	Properly close the top cover.	Go to step 4. If the paper is jamming in the ADF, then go to “ADF paper jam service check” on page 125 .
<p>Step 4</p> <p>Is the leading edge of the paper wrinkled or torn?</p>	Use different media.	Go to step 5.
<p>Step 5</p> <p>Perform the ADF pick motor and ADF feed motor tests.</p> <p>Are the motors working properly?</p>	Go to step 6.	Go to step 8.

Actions	Yes	No
<p>Step 6 Perform the ADF paper present sensor test. See “Scanner tests” on page 256.</p> <p>Is the sensor working properly?</p>	Go to step 7.	Go to step 8.
<p>Step 7 Check the ADF sensor actuators to see if they are dirty or jammed.</p> <p>Are the actuators okay?</p>	If any actuators on the ADF are broken, then replace the ADF unit. See “ADF unit removal” on page 402 .	Go to step 8.
<p>Step 8 Properly connect all the connections in the ADF relay card and controller board.</p> <p>Did this fix the situation?</p>	Problem resolved	Go to step 9.
<p>Step 9 Check the ADF cable for continuity.</p> <p>Is there continuity?</p>	Go to step 11.	Go to step 10.
<p>Step 10 Replace the ADF cable. See “ADF cable removal” on page 408.</p> <p>Does this fix the problem?</p>	Problem resolved.	Go to step 11.
<p>Step 11 Replace the ADF. See “ADF unit removal” on page 402.</p> <p>Does this fix the situation?</p>	Problem solved.	Replace the controller board. See “Controller board removal” on page 320 .

Black or blank page copy service check

Actions	Yes	No
<p>Step 1 Print a menu page, or a page from the host.</p> <p>Is the page black?</p>	See “Solid black pages check” on page 65 .	Go to step 2.
<p>Step 2 Is the copy an ADF scan?</p>	Go to step 4.	Go to step 3.
<p>Step 3 Run a flatbed copy.</p> <p>Is it blank or black?</p>	Go to step 5.	Go to step 4.

Actions	Yes	No
Step 4 Did the sheet feed into the ADF?	Go to step 5.	Perform an ADF paper feed test.
Step 5 Is the CCD ribbon cable properly connected to J30 on the controller board?	Go to step 6.	Properly connect the ribbon cable to JCIS1.
Step 6 Replace the flatbed unit. See “Flatbed assembly removal” on page 412. Did this fix the problem?	The problem is solved.	Go to step 7.
Step 7 Replace the controller board. See “Controller board removal” on page 320. Did this fix the problem?	The problem is solved.	Consult the next level of support.

Modem/fax card service check

Note: This service check should be used if the paper feeds and jams in the ADF. If the paper is not feeding into the ADF see [“ADF feed errors service check” on page 205.](#)

Actions	Yes	No
Step 1 Is the phone line properly connected to the modem card and the wall jack?	Go to step 2.	Go to step 3.
Step 2 Properly connect the phone line to the modem card and wall jack. Did this fix the problem?	Problem resolved.	Go to step 3.
Step 3 Test the ability of the phone line to send and receive calls. Did the phone line work properly?	Go to step 5.	Go to step 4.
Step 4 Use the MFP on a properly functioning phone jack. Did this fix the problem?	Problem resolved.	Go to step 5.
Step 5 Is the modem card ribbon cable properly connected to the controller board at JMOD2 and the modem card?	Go to step 7.	Go to step 6.

Actions	Yes	No
<p>Step 6 Properly connect the modem card cable to the modem card and controller board.</p> <p>Did this fix the problem?</p>	Problem resolved.	Go to step 7.
<p>Step 7 Check the modem card ribbon cable for continuity.</p> <p>Is there continuity?</p>	Go to step 8.	Replace the modem card cable.
<p>Step 8 Check the voltages from connector JMOD2 on the controller board. Check Pin 1, 9, 12 and 13 for +3.3VDC. Pin 10 for +5VDC. Pins 2, 4, 5, 6, 7, and 8 are grounds.</p> <p>Are the signals or voltages present?</p>	Replace the fax card. See “Modem removal” on page 326.	Replace the controller board. See “Controller board removal” on page 320.

ADF streak service check

Actions	Yes	No
Do streaks appear on the middle of scans when using the ADF?	Clean the ADF glass on the flatbed using a lint-free cloth. Also, clean the separator roll and pad with a damp cloth.	No issue to fix.

Blank spaces on incoming fax service check

Actions	Yes	No
<p>Step 1 Have a fax sent from another machine.</p> <p>Does the problem remain?</p>	Go to step 2.	The problem is solved.
<p>Step 2 Attach the MFP to a different phone line.</p> <p>Does the problem remain?</p>	Go to step 3.	The problem is solved.
<p>Step 3 Print a test page.</p> <p>Does the image quality issue remain?</p>	Go to step 4.	The problem is solved.

Actions	Yes	No
<p>Step 4 Install a new toner cartridge.</p> <p>Does the problem remain?</p>	Contact the next level of support.	The problem is solved.

Fax transmission service check

Actions	Yes	No
<p>Step 1 Is the phone line properly connected to the modem card and to the wall jack?</p>	Go to step 2.	Go to step 3.
<p>Step 2 Properly connect the phone line to the modem card and to the wall jack.</p> <p>Did this fix the problem?</p>	The problem is solved.	Go to step 3.
<p>Step 3 Check for a dial tone.</p> <p>Is there a dial tone?</p>	Go to step 4.	Go to step 6.
<p>Step 4 Use a telephone to test the phone line's ability to send and receive calls.</p> <p>Did the phone line work properly?</p>	Go to step 7.	Go to step 5.
<p>Step 5 Use a telephone handset to verify the phone line is free of static or external noise.</p> <p>Is the phone line noise-free?</p>	Go to step 7.	Go to step 6.
<p>Step 6 Use the MFP on a properly functioning phone jack.</p> <p>Did this fix the problem?</p>	The problem is solved.	Go to step 7.
<p>Step 7 In the Diagnostics menu or Configuration menu, verify that the Enable Fax Receive setting is On.</p> <p>Is the setting set to On?</p>	Go to step 9.	Go to step 8.
<p>Step 8 Set "Enable Fax Receive" to On.</p> <p>Did this fix the problem?</p>	The problem is solved.	Go to step 9.

Actions	Yes	No
Step 9 Is Distinctive Ring enabled?	Go to step 11.	Go to step 10.
Step 10 Turn on Distinctive ring. Did this fix the problem?	The problem is solved.	Go to step 11.
Step 11 Is the phone line analog?	Go to step 13.	Go to step 12.
Step 12 IS the VOIP server configured to support fax?	Go to step 13.	Stop here. This is an issue with the VOIP provider.
Step 13 Does the MFP have reception issues with only a certain remote device?	Go to step 14.	Go to step 15.
Step 14 Verify communications with a different remote device. Can the other device receive faxes?	The issue is with the other device.	Go to step 15.
Step 15 Go to the Administrator menu. Enter the Fax settings - Analog Fax Settings submenu. Verify the Block No Name Fax user setting. Is it enabled?	Go to step 16.	Go to step 17.
Step 16 Disable Block No Name Fax user setting. Did this fix the issue?	The problem is solved.	Go to step 17.
Step 17 Go to the Administrator menu. Enter the Fax settings - Analog Fax Settings submenu. Verify the remote device number is not in the Banned Fax List user setting. Is the remote device number in the banned fax list?	Go to step 18.	Go to step 19.
Step 18 Remove the remote number from the banned fax list. Did this fix the problem?	The problem is solved.	Go to step 19.

Actions	Yes	No
<p>Step 19</p> <p>Press **411 to enter the SE menu, enter Modem settings, and then select Receive Threshold.</p> <p>Test by adjusting the received signal level by decreasing/increasing the Receive Threshold setting in steps of 2db. For example, if default value is -43 db, changing it to -45db will decrease the received signal level by 2db, and changing it to -41db will increase the received signal level by 2db. Recommended adjustment range is between -33db and -48db (in 2db steps).</p> <p>Did this fix the problem?</p>	The problem is solved.	Go to step 20.
<p>Step 20</p> <p>Press **411 to enter the SE Menu. Select "Print Logs".</p> <p>Print the T30 transmission/job log. Check the error code being reported. See "Fax error log codes" on page 214.</p> <p>Did this fix the problem?</p>	The problem is solved.	Contact your second-level of support. See "Escalating a fax issue to second-level support" on page 218 .

Fax reception service check

Note: Before performing this service check, verify that the correct country code for the MFP is selected. This setting must match the country in which the MFP is used to transmit and receive faxes. If the setting is wrong, then change the modem settings in the Fax/SE menu. See step 14. These settings should only be performed with guidance from your second-level support.

Actions	Yes	No
<p>Step 1</p> <p>Is the phone line properly connected to the modem card and the wall jack?</p>	Go to step 2.	Go to step 3.
<p>Step 2</p> <p>Properly connect the phone line to the modem card and to the wall jack.</p> <p>Did this fix the problem?</p>	The problem is solved.	Go to step 3.
<p>Step 3</p> <p>Test the ability of the phone line to send and receive calls.</p> <p>Did the phone line work properly?</p>	Go to step 5.	Go to step 4.
<p>Step 4</p> <p>Use the MFP on a properly functioning phone jack.</p> <p>Did this fix the problem?</p>	The problem is solved.	Go to step 5.

Actions	Yes	No
<p>Step 5 Is the MFP using an analog phone line?</p>	Go to step 8.	Go to step 6.
<p>Step 6 Is the MFP using a VOIP line?</p>	Go to step 7.	Go to step 8.
<p>Step 7 Have the system administrator verify that the VOIP server is configured to receive faxes. Is the server properly configured?</p>	Go to step 8.	Stop here. The issue is VOIP related. The VOIP provider needs to change the server configuration.
<p>Step 8 Is the MFP on a PABX?</p>	Go to step 9.	Go to step 10.
<p>Step 9 Enable Behind a PABX under fax settings in the Administration menu. Did this fix the issue?</p>	The problem is solved.	Disable Behind a PABX , and go to step 10.
<p>Step 10 Is a dial prefix needed to get an outside line?</p>	Go to step 11.	Go to step 12.
<p>Step 11 Try sending a fax using a dial prefix. Did the fax transmit?</p>	The problem is solved.	Go to step 12.
<p>Step 12 Is the fax failing to send to one specific destination?</p>	Go to step 13.	Go to step 14.
<p>Step 13 Check the device that cannot receive a fax. Can it send a fax?</p>	Go to step 14.	Stop here. The issue is with the other device.
<p>Step 14 Press **411 to enter the Fax/SE Menu. Select Print Logs. Print the T30 transmission log. Check the error being reported against the fax error code table. See “Fax error log codes” on page 214. Perform the suggested resolution for the error. Did this fix the problem?</p>	The problem is solved.	Go to step 15.

Actions	Yes	No
<p>Step 15</p> <p>Press **411 to enter the SE menu, then enter Modem settings, and then select Transmit Level.</p> <p>Test by adjusting the transmitted signal strength by decreasing/increasing the 'Transmit Level' setting in steps of 1db. For example, if default value is -11db, changing it to -12db will decrease the signal strength by 1db, and changing it to -10db will increase the signal strength by 1db. Recommended adjustment range is ± 5 db (in 1db steps) from the default value.</p> <p>Did this fix the problem?</p>	The problem is solved.	Go to your second-level of support. See “Escalating a fax issue to second-level support” on page 218 .

Flatbed legal scan service check

Action	Yes	No
<p>Step 1</p> <p>Check the JPLEN1 connector on the controller board for proper connection.</p> <p>Is it properly connected?</p>	Go to step 3.	Go to step 2.
<p>Step 2</p> <p>Reconnect the cable to the controller board.</p> <p>Did this fix the problem?</p>	The problem is solved.	Go to step 3.
<p>Step 3</p> <p>Enter diagnostics mode and navigate to: SCANNER TESTS > Sensor Test</p> <p>Select Paper FB Long to perform the sensor test.</p> <p>Did it pass?</p>	Go to step 5.	Go to step 4.
<p>Step 4</p> <p>Replace the flatbed. See “Flatbed assembly removal” on page 412.</p> <p>Did this fix the problem?</p>	The problem is solved.	Go to step 5.
<p>Step 5</p> <p>Replace the controller. See “Controller board removal” on page 320.</p> <p>Did this fix the problem?</p>	The problem is solved.	Contact the next level of support.

ADF rattling noise service check

Actions	Yes	No
Step 1 Is the ADF separator roller properly installed?	If the error persists, then go to step 2.	Replace the ADF separator roll. Go to “ADF separator roll removal” on page 399.
Step 2 Is the ADF top cover assembly properly installed?	If the error persists, then contact the next level of support.	Replace the ADF top cover assembly. Go to “ADF top cover assembly removal” on page 407.

Flatbed motor service check

Actions	Yes	No
Step 1 Ensure that the flatbed motor cable JFB1 is connected. Is the cable connected?	Go to step 2.	Properly connect the cable.
Step 2 Replace the flatbed unit. See “Flatbed assembly removal” on page 412. Is voltage present?	The problem is solved.	Go to step 3.
Step 3 Replace the controller board. See “Controller board removal” on page 320. Did this solve the problem?	The problem is solved.	Contact the next level of support.

Fax error log codes

Error code	Description	Action
000	No error occurred during fax transmission.	No action is needed.
200	Error occurred when transmitting training.	<ul style="list-style-type: none"> • Check line quality. • Select a lower Max Speed value under Fax Send settings. • Adjust the transmit level.
3XX	Error occurred when receiving image data.	<ul style="list-style-type: none"> • Check line quality. • Adjust Receive Threshold. • Select a lower Max Speed value under Fax Receive settings.

Error code	Description	Action
4XX	Error occurred when sending image data.	<ul style="list-style-type: none"> • Check line quality. • Adjust 'Transmit Level'. • Select a lower 'Max Speed' value under Fax Receive settings.
5XX	Received unknown response from remote fax device.	No action needed. Issue is with the other device.
6XX	Error occurred when receiving a frame.	<ul style="list-style-type: none"> • Check line quality. • Adjust 'Receive Threshold'.
7XX	Error occurred when sending a frame.	<ul style="list-style-type: none"> • Check line quality. • Adjust 'Transmit Level'. • Select a lower 'Max Speed' value under Fax Send settings.
800	Received EOT unexpectedly from the modem in V34 mode.	If error persists, then disable V34 modulation scheme.
802	Too many timeouts occurred during ECM reception.	If error persists, then disable ECM mode.
803	Fax cancelled by user	No action needed.
804	Unexpectedly received a disconnect command from the remote end.	<ul style="list-style-type: none"> • Check line quality. • Adjust Transmit Level/Receive Threshold values. • Remote device could be requesting an unsupported feature.
805	Remote fax device failed to respond to the DCS command.	<ul style="list-style-type: none"> • Adjust Transmit Level/Receive Threshold values. • Remote device could be malfunctioning.
808	T1 timeout occurred when trying to establish a connection with a remote fax device.	Adjust Transmit Level/Receive Threshold values.
809	T2 Timeout occurred due to loss of command/response synchronization.	Adjust Transmit Level/Receive Threshold values.
80A	T5 Timeout occurred when transmitting image data to remote fax device.	<ul style="list-style-type: none"> • Check line quality. • Adjust 'Transmit Level'. • Select a lower 'Max Speed' value under Fax Send settings.
80B	Too many errors when transmitting in ECM mode.	<ul style="list-style-type: none"> • Check line quality. • Adjust 'Transmit Level'. • Select a lower 'Max Speed' value under Fax Send settings.
80C	Remote device failed to respond to the CTC command.	<ul style="list-style-type: none"> • Select a lower 'Max Speed' value under Fax Send settings. • Adjust 'Transmit Level'.

Error code	Description	Action
80D	Received too many requests from remote end to repeat the previous command sent.	<ul style="list-style-type: none"> • Check line quality. • Adjust 'Transmit Level'. • Check if line conditions on remote end will facilitate a good connection.
80E	Functional limitation-Remote fax device does not support G3 receive capability.	No action needed. Issue with the remote device.
811	Failed to detect a fax device at the remote end.	<ul style="list-style-type: none"> • Verify MFD is answering to fax call and not a voice call. • Decrease value of 'Rings To Answer' setting.
812	No more data rates available in V34 modulation scheme.	Adjust to a lower modulation scheme.
813	Timeout occurred after waiting too long to receive a good frame.	Adjust "Receive Threshold".
814	Tried too many times at selected speed using V34 modulation scheme.	<ul style="list-style-type: none"> • Adjust 'Transmit Level'. • Adjust to a lower modulation scheme.
815	Fax transmission was interrupted due to power failure.	Troubleshoot MFP if error persists. See "Modem/fax card service check" on page 207.
818	Fax transmission failed due to insufficient memory to store scanned image.	Adjust 'Memory Use' setting to allocate more memory for send jobs.
819	Fax transmission failed due to insufficient memory to store received image.	Adjust 'Memory Use' setting to allocate more memory for receive jobs.
81A	A timeout occurred during transmission of a page in ECM mode.	Select a lower 'Max Speed' value under Fax Send settings.
880	Failure to transmit training successfully in V17, V29, V27 terminal modulation schemes.	<ul style="list-style-type: none"> • Select a lower "Max Speed" under Fax Send settings. • Adjust the "Transmit Level". • Check line quality.
881	Failure to transmit training successfully in V33, V29, V27 terminal modulation schemes.	<ul style="list-style-type: none"> • Select a lower "Max Speed" under Fax Send settings. • Adjust the "Transmit Level". • Check line quality.
882	Failure to transmit training successfully in V17, V29 terminal modulation schemes.	<ul style="list-style-type: none"> • Select a lower "Max Speed" under Fax Send settings. • Adjust the "Transmit Level". • Check line quality.
883	Failure to transmit training successfully in V17, V27 terminal modulation schemes.	<ul style="list-style-type: none"> • Select a lower "Max Speed" under Fax Send settings. • Adjust the "Transmit Level". • Check line quality.

Error code	Description	Action
884	Failure to transmit training successfully in V29, V27 terminal modulation schemes.	<ul style="list-style-type: none"> • Select a lower “Max Speed” under Fax Send settings. • Adjust the “Transmit Level”. • Check line quality.
885	Failure to transmit training successfully in V17 terminal modulation scheme.	<ul style="list-style-type: none"> • Select a lower “Max Speed” under Fax Send settings. • Adjust the “Transmit Level”. • Check line quality.
886	Failure to transmit training successfully in V29 terminal modulation scheme.	<ul style="list-style-type: none"> • Select a lower “Max Speed” under Fax Send settings. • Adjust the “Transmit Level”. • Check line quality.
887	Failure to transmit training successfully in V27 terminal modulation scheme.	<ul style="list-style-type: none"> • Select a lower “Max Speed” under Fax Send settings. • Adjust the “Transmit Level”. • Check line quality.
888	Failure to transmit training successfully at 2400 bps in V27 terminal modulation scheme.	<ul style="list-style-type: none"> • Adjust “Transmit Level”. • Check line quality.
889	Failed to connect at the minimum speed supported by the MFP.	<ul style="list-style-type: none"> • Adjust “Transmit Level”. • Incompatible connection.
88A	Failed to connect using V.34 modulation scheme.	<ul style="list-style-type: none"> • Check line quality. • Adjust to a lower modulation scheme. • Adjust Transmit Level Receive Threshold values.
901	No fax tones detected from remote end.	<ul style="list-style-type: none"> • Verify destination phone number. • Verify that the remote fax is authorized to receive faxes.
902	No dial tone detected.	<ul style="list-style-type: none"> • Check by enabling ‘Behind a PABX’ setting. • Check phone line. • Check MFD modem hardware.
903	Busy tone detected.	Check with remote end if successive attempts fail.
904	Hardware error detected.	See “Modem/fax card service check” on page 207 .
905	A timeout occurred after dialing the number and waiting for a response.	Check with remote end if successive attempts fail.
906	Fax cancelled by user.	No action needed.

Error code	Description	Action
907	Modem detected a digital line connection.	Verify the MFP is connected to an analog line. See “Fax transmission service check” on page 209 .
908	Phone line was disconnected	Restore phone line connection.
A00	Received request for unsupported function from remote fax device.	No action needed.
A01	Received request for unsupported image width from remote fax device.	No action needed.
A02	Received request for unsupported image resolution from remote fax device.	No action needed.
A03	Received request for unsupported compression type from remote fax device.	No action needed.
A04	Received request for unsupported image length from remote fax device.	No action needed.
F00	Unknown error occurred.	No action needed.

Escalating a fax issue to second-level support

Before contacting the second-level support, go to the SE menu on the MFP, and then generate a Fax error file. This file contains printer settings information and debug information that will help second-level support determine the cause of a failure.

To generate the fax error file, perform the following steps:

- 1 In a Web browser, type **http://MFP/<IP address>/se**.
- 2 The MFP's SE menu page will display. Click the “Dump Job History” link. The following displays:

Fax Job Log							
Wednesday, 2006-02-08 11:25							
Action	Date	Time	Job #	Length	Station Name/Number	Pages	Status
SCAN	1969-12-31	19:00				9	OK
SEND	2006-02-01	13:55	73	17:53	4039	2	CANCELED
SEND	2006-02-01	13:56	74	17:53	4039	0	CANCELED

- 3 Write down the type of connection, the type of error, and the job in which the error occurred.
- 4 In the Web browser address bar, type **http://MFP/<IP address>/se**.
- 5 Click **Report a Fax Problem**. The fax check list displays.

- 6 Fill in the requested information. This is where you will type in the information you retrieved in step 3. Second-level support can assist you if you have questions about the information requested on the page.

Title/Name of Tester	<input type="text" value="Your Name"/>	Date of Event	<input type="text" value="Date of Event"/>	mm/dd/yyyy
Customer	<input type="text" value="Customer Name"/>	Time of Event	<input type="text" value="Time of Event"/>	hh:mm [A,P]M
Job ID	<input type="text" value="Job ID"/>	#		
Describe the Physical Connection:				
Type:	Description:		Channel Quality:	
<input checked="" type="radio"/> Analog	<input type="checkbox"/> VoIP/FoIP		<input checked="" type="radio"/> Clear	
<input type="radio"/> Digital	<input type="checkbox"/> PAB		<input type="radio"/> OK	
	<input type="checkbox"/> ISD		<input type="radio"/> Some Noise	
			<input type="radio"/> Very Noisy	

Note: The fields requesting the code levels, model number, and type of problem are auto-filled. If the information is not in the fields, it can be retrieved from the SE menu. The SE menu can be accessed by pressing ****411** or typing **http://MFP/<IP address>/se** in a Web browser.

- 7 After all the requested information is entered into the Fax Checklist Web page, press the **Submit** button on the bottom of the page. A dialogue asking you to save the file appears.

Note: The file generated by the MFP is not automatically transmitted to second-level support. It is placed on the computer desktop.

- 8 Enter a name for the file, and indicated where you want to save the file.
- 9 Press **OK**. The file appears on the desktop.
- 10 E-mail the file to second-level support.

Stretched words on incoming fax service check

Actions	Yes	No
Have a fax sent from another machine.	Contact the next level of support.	The problem is solved.
Does the problem remain?		

Input/output option hardware errors

321–344 errors

321 error messages

Error code	Description	Action
321.51	Motor 1 (Pick/Lift) motor no first encoder	Go to “Option tray pick/lift motor service check” on page 222.
321.52	Motor 1 (Pick/Lift) motor stop error	
321.53	Motor 1 (Pick/Lift) PWM underflow (motor overspeed)	

322 error messages

Error code	Description	Action
322.54	Motor 2 (Separator/Pass through) motor no first encoder	Go to “Option tray separator/pass through motor service check” on page 222.
322.55	Motor 2 (Separator/Pass through) motor stop error	
322.56	Motor 2 (Separator/Pass through) PWM underflow (motor overspeed)	

324 error messages

Error code	Description	Action
324.57	Motor 3 motor no first encoder	Go to “Option tray ACM motor service check” on page 223.
324.58	Motor 3 motor stop error	
324.59	Motor 3 PWM underflow (motor overspeed)	

325 error messages

Error code	Description	Action
325.60	Hardware error—Board ID unknown	Go to “Option tray controller card service check” on page 223.
325.61	Hardware error—Option type unknown	
325.62	Hardware error—Product ID unknown	
325.63	Hardware error—Sensors are not plugged on the board.	

331 error messages

Error code	Description	Action
331.51	Motor 1 (Pick/Lift) motor no first encoder	Go to “Option tray pick/lift motor service check” on page 222.
331.52	Motor 1 (Pick/Lift) motor stop error	
331.53	Motor 1 (Pick/Lift) PWM underflow (motor overspeed)	

332 error messages

Error code	Description	Action
332.54	Motor 2 (Separator/Pass through) Motor no first encoder	Go to “Option tray separator/pass through motor service check” on page 222.
332.55	Motor 2 (Separator/Pass through) motor stop error	
332.56	Motor 2 (Separator/Pass through) PWM underflow (motor overspeed)	

334 error messages

Error code	Description	Action
334.57	Motor 3 motor no first encoder	Go to “Option tray ACM motor service check” on page 223.
334.58	Motor 3 motor stop error	
334.59	Motor 3 PWM underflow (motor overspeed)	

335 error messages

Error code	Description	Action
335.60	Hardware error—Board ID unknown	Go to “Option tray controller card service check” on page 223.
335.61	Hardware error—Option type unknown	
335.62	Hardware error—Product ID unknown	
335.63	Hardware error—Sensors are not plugged on the board.	

341 error messages

Error code	Description	Action
341.51	Motor 1 (Pick/Lift) motor no first encoder	Go to “Option tray pick/lift motor service check” on page 222.
341.52	Motor 1 (Pick/Lift) motor stop error	
341.53	Motor 1 (Pick/Lift) PWM underflow (motor overspeed)	

342 error messages

Error code	Description	Action
342.54	Motor 2 (Separator/Pass through) motor no first encoder	Go to “Option tray separator/pass through motor service check” on page 222.
342.55	Motor 2 (Separator/Pass through) motor stop error	
342.56	Motor 2 (Separator/Pass through) PWM underflow (motor overspeed)	

344 error messages

Error code	Description	Action
344.57	Motor 3 motor no first encoder	Go to “Option tray ACM motor service check” on page 223.
344.58	Motor 3 motor stop error	
344.59	Motor 3 PWM underflow (motor overspeed)	

Option tray pick/lift motor service check

Action	Yes	No
<p>Step 1</p> <p>a Remove the option tray insert.</p> <p>b Check the lift plate and gears for proper operation by moving the metal plate.</p> <p>Do the lift plate and gears move freely, and are they free of wear or damage?</p>	Go to step 2.	Replace the tray insert.
<p>Step 2</p> <p>Check the pick/lift motor for the following:</p> <ul style="list-style-type: none"> • Gear tooth breakage • Freedom of rotation <p>Is it free of wear or damage?</p>	Go to step 3.	Replace the tray.
<p>Step 3</p> <p>Check the cable J11 on the option tray controller card.</p> <p>Is it properly connected and free of damage?</p>	Contact the next level of support.	Replace the tray.

Option tray separator/pass through motor service check

Action	Yes	No
<p>Step 1</p> <p>a Remove the option tray insert.</p> <p>b Check the separator roll assembly gear under the tray base for the following:</p> <ul style="list-style-type: none"> • Gear tooth breakage • Freedom of rotation <p>Does it move freely, and is it free of wear or damage?</p>	Go to step 2.	Replace the tray.
<p>Step 2</p> <p>Check the cable J10 on the option tray controller card.</p> <p>Is it properly connected and free of damage?</p>	Go to step 3.	Replace the tray.
<p>Step 3</p> <p>Check the separator roll assembly for wear or damage.</p> <p>Is it free of wear or damage?</p>	Contact the next level of support.	Replace the separator roll assembly. See “Separator roll assembly removal” on page 416.

Option tray ACM motor service check

Action	Yes	No
<p>Step 1</p> <p>Check the cable J11 on the option tray controller card.</p> <p>Is it properly connected?</p>	Go to step 2.	Reseat the cable.
<p>Step 2</p> <p>a Remove the option tray insert and bypass the tray present sensor.</p> <p>b POR into the Diagnostics Menu and perform a feed test: Diagnostics Menu > Feed Test > choose an option tray</p> <p>c Check the ACM for proper operation.</p> <p>Does the ACM freely rotate three times before displaying a jam message?</p>	Go to step 3.	Replace the ACM assembly. See “ACM assembly removal” on page 418.
<p>Step 3</p> <p>Is the ACM gear free of wear or damage?</p>	Contact the next level of support.	Replace the ACM assembly. See “ACM assembly removal” on page 418.

Option tray controller card service check

Action	Yes	No
<p>Step 1</p> <p>Check all connections to the option tray controller card.</p> <p>Are the properly connected?</p>	Go to step 2.	Reseat the cables.
<p>Step 2</p> <p>Check printer's firmware level.</p> <p>Is it up to date?</p>	Go to step 3.	Update the firmware.
<p>Step 3</p> <p>Replace the option tray.</p> <p>Does the error remain?</p>	Contact the next level of support.	The problem is solved.

381 errors

381 error messages

Error code	Description	Action
381.51	No encoder feedback detected from the staple finisher ejector motor.	Go to “Ejector motor failure service check” on page 224.
381.52	Motor stop error—the ejector motor kept on running some time after the motor was commanded to stop.	
381.54	No encoder feedback detected from the staple finisher interface/main motor.	
381.55	Motor stop error—the interface/main motor kept on running some time after the motor was commanded to stop.	
381.56	The staple finisher interface/main motor went over the normal speed.	

Ejector motor failure service check

Action	Yes	No
<p>Open the stapler service cover and check the ejector motor cable connection on the stapler controller board.</p> <p>Is it properly connected?</p>	<p>If the error persists, then replace the staple finisher option. Go to “Staple finisher option removal” on page 421.</p>	<p>Reseat the ejector motor connector.</p>

Other symptoms

Base printer symptoms

Symptom	Action
No Display	Go to “Control panel service check” on page 227.
Fuser parts melted	Go to “LVPS service check” on page 176.
Printer not communicating with host (USB)	Go to “USB print service check” on page 229.
Printer not communicating with host (Network)	Go to “Network service check” on page 231.
Machine does not POR (no power)	Go to “Dead machine service check” on page 225.

Symptom	Action
False Close front door displayed.	Go to “Front door not closed service check” on page 230.
False Remove paper from standard bin displayed.	Go to “Bin full service check” on page 234.

Dead machine service check

Action	Yes	No
Step 1 Is the machine plugged in?	Go to step 3.	Go to step 2.
Step 2 Plug the machine in. Did this fix the problem?	The problem is solved.	Go to step 3.
Step 3 Check the power cord for continuity. Is there continuity?	Go to step 4.	Replace the power cord.
Step 4 Check the AC line voltage to the machine. The voltage should be within the following limits: <ul style="list-style-type: none"> • for 110 V machines—100 to 127 V AC • for 220 V machines—200 to 240 V AC Is the voltage within the limits?	Go to step 5.	Try a different outlet.
Step 5 Check the voltages on the LVPS card. <ul style="list-style-type: none"> • +5 V at pins 17 and 19 • +24 V at pins 11, 13, and 15 Are the voltages correct?	Go to the controller board service check. Go to “Controller board service check” on page 226.	Replace the LVPS. Go to “Power supply removal” on page 361.

Controller board service check

Service checks which involve measuring voltages on the LVPS/HVPS (low voltage power supply/high voltage power supply) board should be performed with the printer positioned on its back side.

Note: When making voltage readings, always use frame ground unless another ground is specified. See the wiring diagram in the back of the book for more information.

Warning—Potential Damage: Do not replace the control panel and controller board at the same time. Each card contains the printer settings. When either of these cards is new, it obtains some of the settings from the other card. Settings are lost when both are new and replaced at the same time.

Action	Yes	No
<p>Step 1 POR the machine.</p> <p>Did the control panel, fuser, fan, and drive motor function at startup?</p>	Go to step 2.	Go to step 3.
<p>Step 2 Run some print jobs.</p> <p>Did any errors occur?</p>	Go to step 3.	There is no issue.
<p>Step 3 Check the cables on the controller board.</p> <p>Are they properly connected?</p>	Go to step 5.	Go to step 4.
<p>Step 4 Properly connect all the cables on the controller board.</p> <p>Does the error remain?</p>	Go to step 5.	The problem is solved.
<p>Step 5 Check the power coming to the controller from the power supply. Verify the following voltages:</p> <ul style="list-style-type: none"> • +5 V at pins 17 and 19 • GND at pins 18, 20 • +24 V at pins 11, 13, and 15 <p>Are the voltages correct?</p>	Go to step 7.	Go to step 6.
<p>Step 6 Replace the power supply.</p> <p>Does the error remain?</p>	Go to step 7.	The problem is solved.
<p>Step 7 Is the control panel functioning properly?</p>	Go to step 9.	Go to control panel service check. Go to “Control panel service check” on page 227.

Action	Yes	No
<p>Step 8 Perform the control panel service check. Go to “Control panel service check” on page 227.</p> <p>Does the error remain?</p>	Go to step 9.	The problem is solved.
<p>Step 9 Is the LED on the bottom of the board illuminating?</p>	Go to step 10.	Replace the controller board. Go to “Controller board removal” on page 320 .
<p>Step 10 Verify the controller board power outputs. See “Controller board” on page 469 for voltages from the controller.</p> <p>Are the voltages correct?</p>	Contact the next level of support.	Replace the controller board. Go to “Controller board removal” on page 320 .

Control panel service check

Warning—Potential Damage: Do not replace the control panel and controller board at the same time. Each card contains the printer settings. When either of these cards is new, it obtains some of the settings from the other card. Settings are lost when both are new and replaced at the same time.

Action	Yes	No
<p>Step 1 Check the connections on the UICC and controller board for proper connections.</p> <p>Are they properly connected?</p>	Go to step 3.	Go to step 2.
<p>Step 2 Properly connect the connectors.</p> <p>Did this fix the problem?</p>	The problem is solved.	Go to step 3.
<p>Step 3 Is the display blank but the LEDs on the panel are functioning?</p>	Go to step 4.	Go to step 5.
<p>Step 4 Replace the display. See “Display removal” on page 346.</p> <p>Does the error remain?</p>	Go to step 5.	The problem is solved.
<p>Step 5 Replace the cable connecting the UICC to the controller board.</p> <p>Does the error remain?</p>	Go to step 6.	The problem is solved.

Action	Yes	No
<p>Step 6 Replace the UICC. See “UICC removal” on page 340.</p> <p>Does the error remain?</p>	Go to step 7.	The problem is solved.
<p>Step 7 Replace the controller board. See “Controller board removal” on page 320.</p> <p>Does the error remain?</p>	Contact the next level of support.	The problem is solved.

Toner starvation service check

Action	Yes	No
<p>Step 1</p> <ul style="list-style-type: none"> a Check if the toner cartridge is a supported and genuine Lexmark supply. If not, then replace it. b Make sure that the toner cartridge is properly installed. c Check the toner cartridge and toner cartridge button for damage. Replace if necessary. d Make sure that the latest firmware is installed. <p>Does the problem remain?</p>	Go to step 2.	The problem is solved.
<p>Step 2 Check the cartridge plunger.</p> <p>Is the cartridge plunger properly attached to the front door and is the spring functioning properly?</p>	Go to step 5.	Go to step 3.
<p>Step 3</p> <ul style="list-style-type: none"> a Install a new cartridge plunger and spring. See “Cartridge plunger removal” on page 331. b Print some pages. <p>Did this fix the problem?</p>	The problem is solved.	Go to step 4.
<p>Step 4 Did a 201.22 error display?</p>	Go to “Cartridge gearbox service check” on page 181.	Go to step 5.
<p>Step 5 Try a different toner cartridge.</p> <p>Did this fix the problem?</p>	The problem is solved.	Go to step 6.

Action	Yes	No
<p>Step 6 Check the connections between the cartridge gearbox and the controller board.</p> <p>Is the cable properly connected to the cartridge gearbox and to the controller board?</p>	Go to step 8.	Go to step 7.
<p>Step 7 Reconnect the cable to the cartridge gearbox and to the controller board.</p> <p>Did this fix the problem?</p>	The problem is solved.	Go to step 8.
<p>Step 8 Replace the cartridge gearbox. See “Cartridge gearbox removal” on page 312.</p> <p>Did this fix the problem?</p>	The problem is solved.	Contact the next level of support.

USB print service check

Action	Yes	No
<p>Step 1 Enter Diagnostic mode and perform a print test to make sure the printer prints correctly. Verify that the indicator light is on, and then print the menu settings page. Navigate to: Reports > Menu Settings Page</p> <p>Are the internal pages printing?</p>	Go to step 2.	Go to step 7.
<p>Step 2 Verify if the user's applications are set up correctly.</p> <p>Are they set up correctly?</p>	Go to step 4.	Go to step 3.
<p>Step 3 Try a different application to run a print job.</p> <p>Did the output print?</p>	This is not a printer issue.	Go to step 4.
<p>Step 4 Check the printer driver.</p> <p>Is the correct driver being used and properly set up?</p>	Go to step 6.	Go to step 5.
<p>Step 5 Use a different driver.</p> <p>Did this fix the issue?</p>	The problem is solved.	Go to step 6.

Action	Yes	No
<p>Step 6 Try a different USB cable.</p> <p>Did this fix the issue?</p>	The problem is solved.	Go to step 7.
<p>Step 7 Replace the controller board. Go to “Controller board removal” on page 320.</p> <p>Did this fix the issue?</p>	The problem is solved.	Contact the next level support

Front door not closed service check

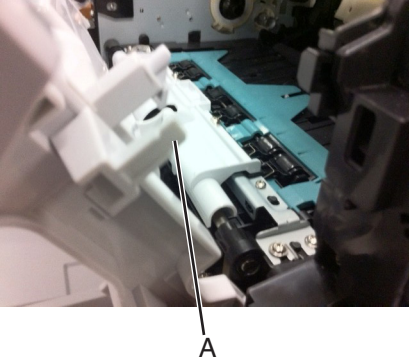
Action	Yes	No
<p>Step 1 Open the front access cover, and then check the interlock switch actuator.</p>  <p>Is the actuator damaged?</p>	Go to step 2.	Go to step 3.
<p>Step 2 Replace the front access cover. See “Front access cover removal” on page 354.</p> <p>Did this resolve the issue?</p>	The problem is solved.	Go to step 3.
<p>Step 3 Check the switch on the front cover for dirt or debris that might keep the switch trigger from properly moving.</p> <p>Is there dirt or debris?</p>	Go to step 4.	Go to step 5.
<p>Step 4 Remove the debris.</p> <p>Did this resolve the issue?</p>	The problem is solved.	Go to step 5.

Action	Yes	No
<p>Step 5 Check pin 2 on J44 for +3.3 V and pin 3 for GND.</p> <p>Are the voltages and grounds correct?</p>	Go to step 6.	Go to step 7.
<p>Step 6 Replace the interlock switch.</p> <p>Did this resolve the issue?</p>	The problem is solved.	Go to step 7.
<p>Step 7 Replace the controller board. See “Controller board removal” on page 320.</p> <p>Did this resolve the issue?</p>	The problem is solved.	Contact the next level of support.

Network service check

Note: Before starting this service check, print out the network setup page. This page is found under **Menu > Reports > Network Settings**. Consult the network administrator to verify that the physical and wireless network settings displayed on the network settings page for the device are properly configured. If a wireless network is used, then verify that the printer is in range of the host computer or wireless access point, and there is no electronic interference. Have the network administrator verify that the device is using the correct SSID, and wireless security protocols. For more network troubleshooting information, consult the Lexmark Network Setup Guide.

Actions	Yes	No
<p>Step 1 If the device is physically connected to the network, verify that the Ethernet cable is properly connected on both ends.</p> <p>Is the cable properly connected?</p>	Go to step 3. If the network is wireless, then go to step 3.	Go to step 2.
<p>Step 2 Connect the Ethernet cable.</p> <p>Does this fix the problem.</p>	The problem is solved.	Go to step 3.
<p>Step 3 Check the printer's online status under Printers and Faxes on the host computer. Delete all print jobs in the print queue.</p> <p>Is the printer online and in a Ready state?</p>	Go to step 5.	Go to step 4.
<p>Step 4 Change the printer status to online.</p> <p>Did this fix the issue?</p>	The problem is solved.	Go to step 5.

Actions	Yes	No
<p>Step 5 Does the IP address displayed on the network settings page match the IP address in the port of the drivers using the printer?</p>	Go to step 10.	Go to step 6.
<p>Step 6 Does the LAN use DHCP? Note: A printer should use a static IP address on a network.</p>	Go to step 7.	Go to step 9.
<p>Step 7 Are the first two segments of the IP address 169.254</p>	Go to step 8.	Go to step 9.
<p>Step 8 POR the printer. Did this resolve the issue?</p>	The problem is solved.	Go to step 10.
<p>Step 9 Reset the address on the printer to match the IP address on the driver. Did this resolve the issue?</p>	The problem is solved.	Go to step 10.
<p>Step 10 Have the network administrator verify that the printer and PC's IP address have identical subnet addresses. Are the subnet addresses the same?</p>	Go to step 12.	Go to step 11.
<p>Step 11 Using the subnet address supplied by the network administrator, assign a unique IP address to the printer. Note: The printer IP address should match the IP address on the printer driver. Did this fix the problem?</p>	The problem is solved.	Go to step 12.
<p>Step 12 Is the device physically connected (Ethernet cable) to the network?</p>	Go to step 13.	Go to step 15.
<p>Step 13 Try using a different Ethernet cable. Did this fix the problem?</p>	The problem is solved.	Go to step 14.
<p>Step 14 Have the network administrator check the network drop for activity. Is the network drop functioning properly?</p>	Replace the controller board. See "Controller board removal" on page 320.	Contact the network administrator.
<p>Step 15 Is the printer on the same wireless network as the other devices?</p>	Go to step 17.	Go to step 16.

Actions	Yes	No
<p>Step 16 Assign the correct wireless network to the printer.</p> <p>Did this fix the problem?</p>	The problem is solved.	Go to step 17.
<p>Step 17 Are the other devices on the wireless network communicating properly?</p>	Go to step 18.	Contact the network administrator.
<p>Step 18 Verify that the wireless card is properly seated on the controller board.</p> <p>Is the wireless card seated correctly?</p>	Go to step 20.	Go to step 19.
<p>Step 19 Properly reseal the wireless card.</p> <p>Did this fix the problem?</p>	The problem is solved.	Go to step 20.
<p>Step 20 If there is an attached antenna, is the antenna damaged?</p>	Go to step 22.	Go to step 21.
<p>Step 21 Replace the antenna.</p> <p>Did this fix the problem?</p>	The problem is solved.	Go to step 22.
<p>Step 22 Verify that the antenna is properly connected to the wireless card.</p> <p>Is it connected correctly?</p>	Go to step 24.	Go to step 23.
<p>Step 23 Properly connect the antenna.</p> <p>Did this fix the problem?</p>	The problem is solved.	Go to step 24.
<p>Step 24 Replace the wireless card.</p> <p>Did this fix the problem?</p>	The problem is solved.	Go to step 25.
<p>Step 25 Replace the controller board. See “Controller board removal” on page 320.</p> <p>Did this fix the problem?</p>	The problem is solved.	Contact the next level of support.

Bin full service check

Action	Yes	No
<p>Step 1 Update the firmware. Note: Contact the next level of support for the correct firmware level.</p> <p>Does the problem remain?</p>	Go to step 2.	The problem is solved.
<p>Step 2 Check the bin full sensor cables for continuity.</p> <p>Is there continuity?</p>	Go to step 3.	<p>Replace the bin full sensor cable. See “Bin full sensor cable removal” on page 394.</p> <p>If the problem remains, then go to step 3.</p>
<p>Step 3 Replace the bin full sensor. See “Bin full sensor/lens removal” on page 392.</p> <p>Does the problem remain?</p>	Go to step 4.	The problem is solved.
<p>Step 4 Replace the controller board. See “Controller board removal” on page 320.</p> <p>Does the problem remain?</p>	Contact the next level of support.	The problem is solved.

Flickering display service check

Action	Yes	No
<p>Step 1 POR the machine.</p> <p>Does the problem remain?</p>	Go to step 2.	The problem is solved.
<p>Step 2 Replace the controller board. See “Controller board removal” on page 320.</p> <p>Does the problem remain?</p>	Contact the next level of support.	The problem is solved.

Service menus

Understanding the printer control panel

Using the printer control panel

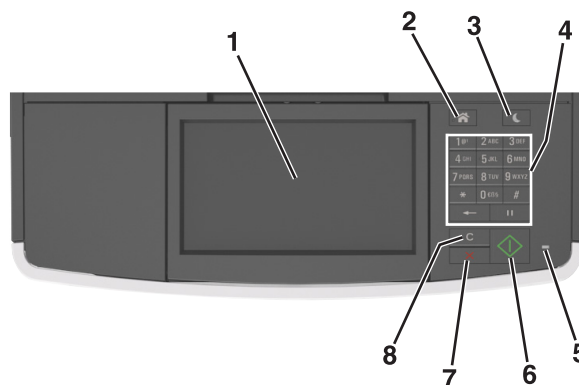

Use the		To
1	Printer control panel	<ul style="list-style-type: none"> View the printer status and messages. Set up and operate the printer.
2	Home button	Go to the home screen.
3	Sleep button	Enable Sleep mode or Hibernate mode. Do the following to wake the printer from Sleep mode: <ul style="list-style-type: none"> Press any hard button. Open a door or cover. Send a print job from the computer. Perform a power-on reset (POR) with the main power switch. Attach a device to the USB port on the printer.
4	Keypad	Enter numbers, letters, or symbols.
5	Indicator light	Check the status of the printer.
6	Start button	Start a job, depending on which mode is selected.
7	Cancel button	Stop all printer activity.
8	Clear All / Reset button	Reset the default settings of a function, such as printing, copying, or e-mailing.

Understanding the colors of the indicator and Sleep button lights

The colors of the indicator and Sleep button lights on the printer control panel signify a certain printer status or condition.

Indicator light	Printer status
Off	The printer is off or in Hibernate mode.
Blinking green	The printer is warming up, processing data, or printing.
Solid green	The printer is on, but idle.
Blinking red	The printer requires user intervention.

Sleep button light	Printer status
Off	The printer is idle or in Ready state.
Solid amber	The printer is in Sleep mode.
Blinking amber	The printer is waking from or entering Hibernate mode.
Blinking amber for 0.1 second, then goes completely off for 1.9 seconds in pulsing pattern	The printer is in Hibernate mode.

Understanding the home screen

When the printer is turned on, the display shows a basic screen, referred to as the home screen. Touch the home screen buttons and icons to initiate an action such as copying, faxing, or scanning; to open the menu screen; or to respond to messages.

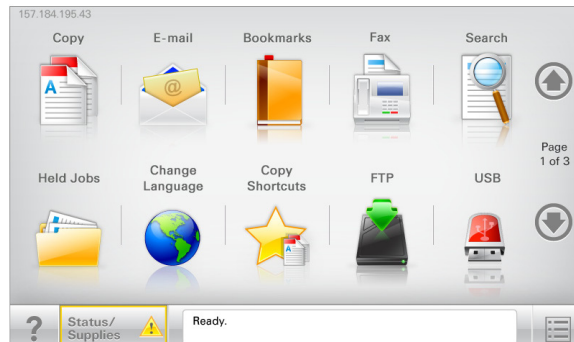

Note: Your home screen may vary depending on your home screen customization settings, administrative setup, and active embedded solutions.



#	Touch	To
1	Change Language	Launch the Change Language pop-up window that lets you change the primary language of the printer.
2	Copy	Access the Copy menus and make copies.
3	Fax	Access the Fax menus and send fax.
4	E-mail	Access the E-mail menus and send e-mails.
5	FTP	Access the File Transfer Protocol (FTP) menus and scan documents directly to an FTP server.
6	Arrows	Scroll up or down.
7	Forms and Favorites	Quickly find and print frequently used online forms.

#	Touch	To
8	Menu icon	Access the printer menus. Note: The menus are available only when the printer is in Ready state.
9	Bookmarks	Create, organize, and save a set of bookmarks (URL) into a tree view of folders and file links. Note: The tree view supports only bookmarks created from this function, and not from any other application.
10	USB Drive	View, select, print, scan, or e-mail photos and documents from a flash drive. Note: This icon appears only when you return to the home screen while a memory card or flash drive is connected to the printer.
11	Held Jobs	Display all current held jobs.
12	Status/Supplies	<ul style="list-style-type: none"> • Show a warning or error message whenever the printer requires intervention to continue processing. • Access the messages screen for more information on the message, and how to clear it.
13	Tips	Open a context-sensitive Help dialog.
14	Search held jobs	Search for one or more of the following items: <ul style="list-style-type: none"> • User name for held or confidential print jobs • Job names for held jobs, excluding confidential print jobs • Profile names • Bookmark container or print job names • USB container or print job names for supported file types

Features

Feature	Description
Menu trail line Example: <u>Menus</u> > <u>Settings</u> > <u>Copy Settings</u> > Number of Copies	A menu trail line is located at the top of each menu screen. This feature shows the path taken to arrive at the current menu. Touch any of the underlined words to return to that menu. Number of Copies is not underlined because it is the current screen. If you touch an underlined word on the “Number of Copies” screen before the number of copies is set and saved, then the selection is not saved, and it does not become the default setting.
Attendance message alert 	If an attendance message affects a function, then this icon appears and the red indicator light blinks.
Warning 	If an error condition occurs, then this icon appears.

Feature	Description
Status message bar	<ul style="list-style-type: none"> • Show the current printer status such as Ready or Busy. • Show printer conditions such as Toner Low or Cartridge Low. • Show intervention messages so the printer can continue processing.
Printer IP address Example: 123 . 123 . 123 . 123	The IP address of your network printer is located at the upper left corner of the home screen and appears as four sets of numbers separated by periods. You can use the IP address when accessing the Embedded Web Server so you can view and remotely configure printer settings even when you are not physically near the printer.

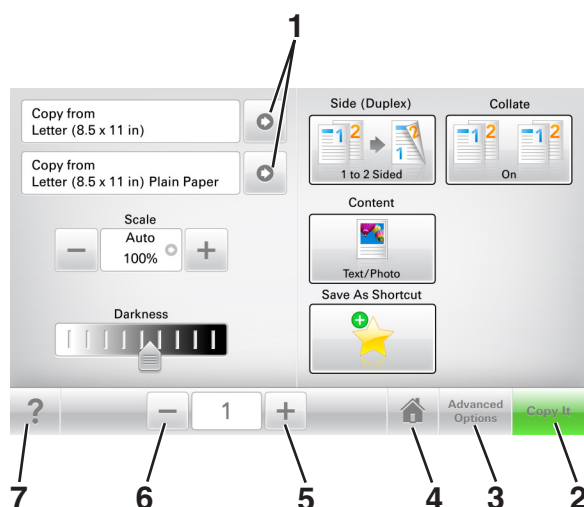

Using the touch-screen buttons

Note: Your home screen, icons, and buttons may vary, depending on your home screen customization settings, administrative setup, and active embedded solutions.



#	Touch	To
1	Arrows	View a list of options.
2	Copy It	Print a copy.
3	Advanced Options	Select a copy option.
4	Home	Go to the home screen.
5	Increase	Select a higher value.
6	Decrease	Select a lower value.
7	Tips	Open a context-sensitive Help dialog.

Other touch-screen buttons

Touch	To
Accept 	Save a setting.
Cancel 	<ul style="list-style-type: none"> • Cancel an action or a selection. • Exit a screen and return to the previous screen without saving changes.
Reset 	Reset values on the screen.

Menus list

Paper Menu

Default Source
 Paper Size/Type
 Configure MP
 Substitute Size
 Paper Texture
 Paper Weight
 Paper Loading
 Custom Types
 Custom Names¹
 Custom Scan Sizes
 Universal Setup

Reports

Menu Settings Page
 Device Statistics
 Stapler Test
 Network Setup Page¹
 Network [x] Setup Page
 Shortcut List
 Fax Job Log
 Fax Call Log
 Copy Shortcuts
 E-mail Shortcuts
 Fax Shortcuts
 FTP Shortcuts
 Profiles List
 Print Fonts
 Print Directory
 Print Demo
 Asset Report

Network/Ports

Active NIC
 Standard Network²
 Standard USB
 Parallel [x]
 Serial [x]
 SMTP Setup

Security

Edit Security Settings
 Miscellaneous Security Settings
 Confidential Print Menu
 Disk Wiping
 Security Audit Log
 Set Date and Time

Settings	Help	Manage Shortcuts	Option Card Menu ³
General Settings	Print All Guides	Fax Shortcuts	A list of installed DLEs (Download Emulators) appears.
Copy Settings	Copy Guide	E-mail Shortcuts	
Fax Settings	E-mail Guide	FTP Shortcuts	
E-mail Settings	Fax Guide	Copy Shortcuts	
FTP Settings	FTP Guide	Profile Shortcuts	
Flash Drive Menu	Print Defects Guide		
Print Settings	Information Guide		
	Supplies Guide		

¹ Depending on the printer setup, this menu appears as Network Setup Page or Network [x] Setup Page.

² Depending on the printer setup, this menu appears as Standard Network or Network [x].

³ This menu appears only when one or more DLEs are installed.

Diagnostics menu

Entering the Diagnostics menu

- 1 Turn off the printer.
- 2 Press and hold **3** and **6** while turning on the printer.
Release the buttons when the splash screen appears.

Registration

These settings adjust the margins of the black plane.

To set the Registration:

- 1 Print a Quick test page.
 - a From the Diagnostics menu, navigate to:
Registration > Quick Test
 - b Retain this page to determine the changes you need to make to the margin settings. The alignment diamonds in the margins should touch the margins of the page.

The Quick test page contains the following information:

- Printer registration settings
- Code levels
- Alignment diamonds at the top, bottom, and each side
- Horizontal lines for skew adjustment
- General printer information, including current page count, installed memory, processor speed, serial number, engine ID, and system card ID

- 2 Change the value of any of the margin settings.

Top Margin	-16 to +16	Increasing the value moves the image down the page. Always adjust the top before the bottom margin.
Bottom Margin	-20 to +20	Increasing the value moves the image toward the top of the page.
Left Margin	-25 to +25	Increasing the value moves the image toward the right margin. Always adjust the left before the right margin.
Right Margin	-30 to +30	Use this to adjust the printhead.

Note: The alignment of the left margin positions the black plane to the right or left. The alignment of the right margin does not alter the margins and should only be used to adjust the printhead.

Scanner calibration

This test calibrates the black and white values for the ADF and flatbed. Use the following values to manually adjust a replacement scanner.

Menu items	Values
Flatbed Black	-10 to 10*
ADF Front Black	-10 to 10*
ADF Back Black	-10 to 10*
Flatbed White	-10 to 10*
ADF Front White	-10 to 10*
ADF Back White	-10 to 10*
* The default value is 0.	

To adjust a calibration value, do the following steps:

- 1** Navigate to **Diagnostics Menu > Scanner Calibration**.
- 2** Select a calibration value to adjust.
- 3** To view the result for an ADF front adjustment, place a test page image side up and touch **Copy Quick Test**. Compare the results to the original. Adjust if necessary.
- 4** To view the result for an ADF back adjustment, place a test page image side down and touch **Copy Quick Test**. Compare the results to the original. Adjust if necessary.
- 5** To view the result for a flatbed adjustment, do the following:
 - a** Remove any paper from the ADF. Compare the results to the original. Adjust as needed.
 - b** Place a test page on the flatbed and touch **Copy Quick Test**.
 - c** Compare the results to the original. Adjust if necessary.

Reset flatbed, ADF front, and ADF back calibration values

These settings revert the selected scan source IQT black and white values back to the Nominal Black and Nominal White settings.

Perform this test only on a replacement scanner.

To reset a scanner calibration value, do the following:

- 1 Navigate to **Diagnostics Menu > Scanner Calibration**.
- 2 Select a calibration value to adjust.
- 3 Apply the changes.

PRINT TESTS

This test determines if the printer can print on paper from any of the input trays. Each installed tray is available within the Print Tests menu.

The content of the test page varies depending on the paper in the selected input tray.

- If the selected tray contains paper, then a page similar to the Quick Test page is printed but without the print registration diamonds information.
- If the selected tray contains envelopes, then an envelope print test pattern is printed. If Continuous is selected, then the envelope print test pattern is printed on the first envelope and the rest of the envelopes are blank.

The Print Test page always prints one-sided, regardless of the duplex setting or the presence of the duplex option.

- 1 Enter the Diagnostics menu, and then select **PRINT TESTS**.
- 2 Select the paper source.
- 3 Select any of the following:
 - **Single**—This option prints a single Print Test page (no buttons are active while the test page is printing).
 - **Continuous**—This option continuously prints the Print Test page until **X** is pressed.

Print Quality Pages

This enables the user to view the values of the printer settings and to test its ability to generate acceptable printed output.

The report consists of four pages. The printer always uses media from Tray 1 to print this report. It will not prompt for a change in media regardless of the media type in Tray 1.

Note: This test cannot be canceled after it has begun. If duplex is activated, then the report is printed in duplex.

To print the Print quality pages:

From the Diagnostics menu, navigate to **Print Tests > Print Quality Pages**.

HARDWARE TESTS

If the hardware test fails, replace the failing part.

Panel Test

This test verifies the function of the control panel display.

- 1 Enter the Diagnostics menu, and then navigate to:

Hardware Tests > Panel Test

- 2 Exit the test.

Button Test

This test verifies the control panel button function except for the Sleep button.

To run the test:

- 1 From the Diagnostics menu, navigate to:

Hardware Tests > Button Test

- 2 The panel displays **Press** and an icon matching one of the control panel buttons. Press the physical button that is represented by the icon, and the printer tests the function of that button.

If the test is successful, then the panel displays another icon to test.

If a button fails the test, or if a different button is pressed, then the panel displays **Test Failed** and returns to the main section of the Hardware tests menu. After three seconds of inactivity, the panel automatically returns to the main section of the Hardware tests menu.

If all buttons pass the test, then the panel displays **PASSED** and returns to the main section of the Hardware tests menu.

- 3 Press **X** or **Back** to exit the test.

To run the test for the MS610de:

- 1 From the Diagnostics menu, navigate to:

Hardware Tests > Button Test

- 2 With no buttons pressed, a pattern matching the control panel buttons is displayed. Press each control panel button one at a time, and the panel highlights the represented button in the matching pattern.

- 3 Release the button, and the highlight disappears.

- 4 Press **X** or **Back** to exit the test.

DRAM Test

This test checks the validity of the standard and optional dynamic random access memory (DRAM). The test repeatedly writes patterns of data to the DRAM to verify that each bit in the memory can be set and read correctly.

- 1 Enter the Diagnostics menu, and then navigate to:
HARDWARE TESTS > DRAM Test
- 2 Testing and resetting the printer messages appear on the display.
- 3 After the printer resets, the results of the test appear: **DRAM Test [x] P:##### F:#####**.
 - **[x]** represents the size of the installed DRAM.
 - **P:#####** represents the number of times the memory test passed and finished successfully. The maximum pass count is 999,999.
 - **F:#####** represents the number of times the memory test failed and finished with errors. The maximum pass count is 999,999.
- 4 After the maximum pass or fail count is reached or when all the DRAM has been tested, the test stops and the final results appear.

Serial Wrap Test

Use this test to check the operation of the Serial Port Hardware using a wrap plug. Each signal is tested. If the test fails, replace the controller board.

To run the Serial Wrap Test:

- 1 Disconnect the serial interface cable, and install the wrap plug.
- 2 From the Diagnostics menu, navigate to **HARDWARE TESTS > Serial Wrap Test**.
- 3 Select the appropriate **Serial Wrap Test** from the list. Values may include **Serial Wrap**, **Serial 1 Wrap**, **Serial 2 Wrap**, or **Serial 3 Wrap**. Each time the test finishes, the screen updates with the result. P and F represent the same numbers for DRAM. If the test passes, the Pass Count increases by 1. However, if the test fails, one of the following failure messages appears for approximately three seconds, and the Fail Count increases by 1:

Receive Status Interrupt Error

Status Error

Receive Data Interrupt Error

Transmit Data Interrupt Error

Transmit Empty Error

Threshold Error

Receive Data Ready Error

Break Interrupt Error

Framing Error

Parity Error

Overrun Error

Data Error

Data 232 Error

Data 422 Error

FIFO Error

DSR Error

DSR PIO Error

DSR Interrupt Error

CTS Error

CTS PIO Error

CTS Interrupt Error

After the maximum count is reached or a failure occurs, the test stops.

- 4 Press **Stop** (X) to cancel the test.

USB HS Test Mode

- 1 From the Diagnostics menu, navigate to:
Hardware Tests > USB HS Test Mode
- 2 Choose the desired port, and then choose the desired test.

Ports	Tests
Port 0	Test J
Port 1	Test K
Port 2	Test SEO NAK
Port 3	Test Packet
	Test Force Enable
Single Step Get Device	
Single Step Set Feature	

- 3 To exit the test, POR the printer.
- 4 If the test fails, replace the failing USB cable.

DUPLEX TESTS

Quick Test

The Duplex quick test determines if the top margin at the back of a duplexed page is set correctly. This test prints a duplexed version of the Quick test page that can be used to adjust the duplex top margin. Use either Letter or A4 paper.

To run the Duplex quick test:

- 1 From the Diagnostics menu, navigate to:
Duplex Tests > Quick Test
- 2 Choose any of the following:
 - Single—Prints a single Quick test page.
 - Continuous—Continuously prints the Quick test pages until **X** is pressed.

The printer attempts to print the Quick test page from the default paper source. If the default paper source supports only envelopes, then the page is printed from Tray 1.

The Quick test page contains the following information:

- Printer registration settings
- Code levels
- Alignment diamonds at the top, bottom, and each side
- Horizontal lines for skew adjustment
- General printer information, including current page count, installed memory, processor speed, serial number, engine ID, and controller board ID

3 Check the Quick test page for the correct offset between the placement of the first scan line on the front and back side of a duplexed sheet.

4 If adjustment is necessary, the top margin in the Registration menu must be adjusted first. The duplex top margin offset may be adjusted next. A positive offset moves the text down the page and widens the top margin, while a negative offset moves the text up the page and narrows the top margin.

Top Margin

This setting controls the offset between the placement of the first scan line on the front and back side of a duplex sheet.

Note: If adjustment is necessary, the top margin in the Registration menu must be adjusted first. The duplex top margin may be adjusted next.

To adjust this setting:

1 From the Diagnostics menu, navigate to:

Duplex tests > Top Margin

2 Change the margin values.

Changing the value by 1 unit moves the margin by 1/100 in. A positive value moves the text down the page and widens the top margin. A negative value moves the text up the page and narrows the top margin.

3 Depending on the printer model, press **OK** or touch  to save the desired margin value.

Left Margin

This setting allows the user to shift the position of the left margin of the back side of a duplexed page to the left or right. The default margin is 1/4 in.

To adjust this setting:

1 From the Diagnostics menu, navigate to:

Duplex Tests > Left Margin

2 Change the margin value.

Each increment corresponds to 4 pels at 600 dpi (0.00666 in. or 0.1693 mm). A more positive offset moves the margin to the right, and a more negative offset moves the margin to the left.

3 Depending on the printer model, press **OK** or touch  to save the desired margin value.

Sensor Test

Use this test to determine if the duplex sensor and switches are working properly.

To run this test:

- 1 From the Diagnostics menu, navigate to:
Duplex Tests > Sensor Test
- 2 **Testing...** appears while the printer is verifying the state of the sensor.
The control panel displays the current state of the sensor.
- 3 Manually actuate the sensor to make it toggle between **Open** and **Closed**. If the sensor does not toggle, then it is malfunctioning.
- 4 Press **X** to exit the test.

Duplex Feed 1

This test feeds a blank sheet of paper from Tray 1 to the duplex paper stop position 1. This test can be run using any of the supported paper sizes.

To run this test:

- 1 From the Diagnostics menu, navigate to:
Duplex Tests > Duplex Feed 1
The power indicator blinks while the paper is feeding, and **Duplex Feed 1 Feeding...** appears. This test cannot be canceled. The panel displays **Duplex Feed 1 Clear Paper** when the paper reaches the duplex paper stop position 1.
- 2 Remove the sheet of paper from the duplex unit, and shut the duplex door.
- 3 Press **X** to clear the message.

INPUT TRAY TESTS

Feed Tests

This test feeds blank pages through the paper path. It can run using any of the paper or envelope sizes supported by the printer.

To run the Feed test:

- 1 From the Diagnostics menu, navigate to:
Input Tray Tests > Feed Tests
- 2 Choose the input source. All installed sources appear.
- 3 Choose any of the following:
 - **Single**—Feeds a single page.
 - **Continuous**—Continuously feeds pages until **X** is pressed.

Sensor Test

Use this test to determine if the input tray sensors are working correctly.

- 1 From the Diagnostics menu, navigate to:

Input Tray Tests > Sensor Test

- 2 Select the input source. All installed sources appear.

Not all sensors appear for all trays. The following table indicates which tray sensors are available for each input source:

Input source	Tray empty sensor	Pass through sensor
Standard tray	✓	
Optional 250-/550-sheet tray	✓	✓
Multipurpose feeder	✓	

- 3 Manually actuate each sensor. The tray empty sensor can be actuated by hand; however, a sheet of paper can be used to cover the pass through sensor.
- 4 Press **X** to exit the test.

OUTPUT BIN TESTS

Feed Tests

This test verifies that media can be fed to a specific output bin. No information is printed on the media.

To run this test:

- 1 From the Diagnostics menu, navigate to:

Output Bin Tests > Feed Tests

- 2 Select the output bin into which you want the paper to exit. All installed output bins appear.
- 3 Select one of the following:
 - Single—Feeds a single page.
 - Continuous—Continuously feeds pages until **X** is pressed.

Sensor Test

This test verifies that the output bin sensors are working correctly.

To run this test:

- 1 From the Diagnostics menu, navigate to:

Output Bin Tests > Sensor Test > Standard Bin

Testing... appears while the printer is verifying the state of the sensor.

The control panel displays the current state of the sensor.

- 2 Manually actuate the sensor to make it toggle between **empty** and **full**. If the sensor does not toggle, then the sensor is malfunctioning.

- 3 Press **X** to exit the test.

FINISHER TESTS

Staple Test

This test verifies the operation of the staple mechanism in the finisher. The printer feeds eight pieces of media to the finisher and accumulates all eight pieces in the finisher. After the last sheets are accumulated, the pack is stapled.

- 1 Enter Diagnostics menu, and then select **FINISHER TESTS**.

- 2 Select **Staple Test**.

Staple Test Running... appears while the test is running.

Feed Test

This test verifies that media can be fed from the default source to a finisher bin. Any paper size that is supported can be used. The printer feeds one blank sheet of media from the default paper source to the finisher bin.

- 1 Enter Diagnostics menu, and then select **FINISHER TESTS**.

- 2 Select **Feed Test**.

Feed Tests Running... appears while the test is running.

Sensor Test

Use this sensor test to determine that the sensors located inside the finisher are operating correctly.



CAUTION—SHOCK HAZARD: Do not use your hand to toggle these switches. Use a nonconducting object.

To run the Sensor test:

- 1 Enter Diagnostics menu, and then navigate to **FINISHER TESTS**.

- 2 Select the sensor from the options listed:

- Staple Sensors
- Pass and Media
- Cover and Door
- Bin Level
- Compile and Diverter
- Initial Sensors

- 3 Manually toggle the selected sensor to verify if the values change between **Open** and **Closed**. If the values do not change, then the sensor is malfunctioning.

- 4 To exit the test, press **X**.

BASE SENSOR TEST

Use the Base Sensor Test to determine that the sensors located inside the printer are operating correctly.

The following sensors can be checked using this test:

- Narrow Media
- Input
- Exit
- Front Door



CAUTION—SHOCK HAZARD: Do not use your hand to toggle these switches. Use a nonconducting item.

To run the Base Sensor Test.

- 1 From the Diagnostics menu, navigate to **BASE SENSOR TEST**.
- 2 Choose a sensor.
- 3 Manually actuate the sensor to verify that it toggles. If the sensor does not toggle, then it is malfunctioning.

Sensor	Values
Input	Open
Output	Closed
Front Door	
Narrow Media	Narrow Wide

- 4 Press **X** to exit the test.

DEVICE TESTS

Quick Disk Test

This test performs a non-destructive read/write test on one block per track on the disk. The test reads one block on each track, saves the data, and then writes and reads four test patterns to the bytes in the block. If the block is good, then the saved data is written back to the disk.

To run the quick disk test:

- 1 From the Diagnostics menu, navigate to:
 - Device Tests > Quick Disk Test.**
 - The power indicator blinks while the test is in progress.
 - **Quick Disk Test/Test Passed** appears if the test passes.
 - **Quick Disk Test/Test Failed** appears if the test fails.
- 2 Press **X** to return to the Device tests menu.

Disk Test/Clean

Warning—Potential Damage: This test destroys all data on the disk and should not be attempted on a good disk. This test may run approximately 1.5 hours, depending on the disk size.

- 1 From the Diagnostics menu, navigate to:
DEVICE TESTS > Disk Test/Clean
Contents will be lost appears.
- 2 Do one of the following:
 - Touch  to continue.
 - Press **X** to cancel.

The test cannot be stopped or canceled after it has begun.
- 3 After the test is complete, a message appears indicating a pass or fail result.
- 4 Press **X** to return to the Device tests menu.

Flash Test

This test verifies the condition of the flash device by writing data to it and then reading data from it.

Warning—Potential Damage: This test destroys all data on the flash device.

Note: After this test is executed, reformat the flash using the Flash Format setting in the Utilities menu.

- 1 From the Diagnostics menu, navigate to:
Device Tests > Flash Test
Files will be lost. Go/Stop? appears.
- 2 Do one of the following:
 - Depending on the printer model, press **OK** or touch  to continue.
 - Press **X** to cancel.

Note: When the test starts, it cannot be stopped or canceled.
- 3 After the test is complete, a message appears indicating a pass or fail result.
- 4 Press **X** to return to the Device tests menu.
- 5 Reformat the flash device using the Flash format setting in the Utilities menu.

PRINTER SETUP

Defaults

Warning—Potential Damage: Modification of the printer setting Defaults causes the NVRAM space to be restored to the printer factory settings.

This setting is used by the printer to determine whether U.S. or non-U.S. factory default values should be used. The following printer settings have different U.S. and non-U.S. values:

Printer default values	U.S. value	Non-U.S. value
Paper Sizes setting in the General Settings menu	U.S.	Metric
Default Paper Size (paper feeding sources which do not have hardware size sensing capabilities)	Letter	A4

Printer default values	U.S. value	Non-U.S. value
Default Envelope Size (envelope feeding sources which do not have hardware size sensing capability)	10 Envelope	DL Envelope
Fax media size	Letter	A4
PCL Symbol Set	PC-8	PC-850
PPDS Code Page	437	850
Universal Units of Measure	Inches	Millimeters

To change this setting:

- 1 From the Diagnostics menu, navigate to:
Printer Setup > Defaults
- 2 Choose U.S. or Non-U.S.
- 3 Do one of the following:
 - Depending on the printer model, press **OK** or touch  to save any changes.
 - Press **X** to return to the Printer setup menu.

Printed Page Count

The value of this setting gauges the amount of usage on the printer. The value of the Printed Page Count setting will equal the values of the Picked Sides meter. After all print tests have been completed, the value will reset to zero.

Note: The value of the setting cannot be changed manually.

Permanent Page Count

The value of this setting indicates the total amount of pages that have been printed. After all print tests have been completed, the value will reset to zero.

Note: The Permanent Page Count value cannot be reset.

Processor ID

This is a 16-digit hexadecimal value representing the ID of the processor on the controller card.

Engine Setting [x]

These settings are used by Engine code ECs to fix field problems. The value of [x] is any value from 1 to 16.

Edge to Edge

When set to On, this shifts all four margins (top, bottom, left, and right) to the physical edge of the page (printable area of a supported paper size). This feature does not work in PPDS emulation.

EP SETUP

EP Defaults

This setting restores each printer setting listed in EP SETUP to its factory default value. Sometimes this is used to help correct print quality problems.

To restore the EP defaults:

- 1 From the Diagnostics menu, navigate to:
EP Setup > EP Defaults
- 2 Select **Restore** to restore the default values, or press **X** to exit without changing the settings.

Fuser Temperature (Fuser Temp)

This setting adjusts the fuser temperature to solve problems with paper curl on low-grade paper and/or melting of letterheads on some papers.

To adjust this setting:

- 1 From the Diagnostics menu, navigate to:
EP Setup > Fuser Temp
- 2 Press **OK** or touch  to save any changes.

Transfer Adjust

This setting controls the transfer roll algorithm.

To adjust this setting:

- 1 From the Diagnostics menu, navigate to:
EP Setup > Transfer Adjust
- 2 Press **OK** or touch  to save any changes.

Print Contrast

This setting controls the developer voltage offset.

To adjust this setting:

- 1 From the Diagnostics menu, navigate to:
EP Setup > Print Contrast
- 2 Press **OK** or touch  to save any changes.

Charge Roll

This setting controls the charge roll voltage.

To adjust this setting:

- 1 From the Diagnostics menu, navigate to:
EP Setup > Charge Roll
- 2 Press **OK** or touch  to save any changes.

Gap Adjust

The setting adjusts the minimum gap between sheets. Increasing this value may reduce curl of some printed media and eliminate some output bin stacking problems. However, increasing this value also results in slower overall performance, measured in pages per minute.

The range of values is 0 to 255, and the default value is 0.

To adjust this setting:

- 1 From the Diagnostics menu, navigate to:
EP Setup > Gap Adjust
- 2 Press **OK** or touch  to save any changes.

Auto Dark Adj

When activated, this setting attempts to optimize the amount of toner used when printing with a specific operating point.

Each time this setting executes, the printer performs the following:

- Calibrates its toner density sensor
- Measures the reflectivity of its bare drum
- Prints patches on the drum and measures the reflectivity of the drum through the patches
- Cleans the transfer roll
- Calculates reflectivity ratios and operating points to attain the darkness target of each operating point
- Modifies the EP mechanism as necessary to adjust toner darkness

The cartridge smart chip controls how often this process executes.

Note: No messages are displayed on the control panel to give any indication that this test is running. The device stores the results of its most recent process in the Auto dark adj field on the Menu settings page report.

When deactivated, the printer disables and never executes this process.

To adjust this setting:

- 1 From the Diagnostics menu, navigate to:
EP Setup > Auto Dark Adj
- 2 Choose **Enable** or **Disable**.
- 3 Press **OK** to save any changes.

REPORTS

Menu Settings Page

This setting prints the Menu Settings Page. The report prints the Diagnostics Menu settings and their current values.

EVENT LOG

Display Log

This version of the Event log displays the panel text that appeared when the event occurred.

To view the Event log:

- 1 From the Diagnostics menu, navigate to:
Event Log > Display Log
- 2 Use the arrow buttons to navigate through the entries.

Print Log

Additional diagnostic information is available when the event log is printed. The first page of the report shows the general device information.

The specific events that appear in the report vary depending on the operational history of the printer. Logs may be printed from the following events:

- Job accounting log failures
- NV reset failures
- NV mirror entries
- 9yy and 1yy (print engine) service error entries
- Programming error entries
- Maintenance count reset entries
- Clear log entries
- Paper jam entries
- Firmware update entries
- JFFS2 partition format entries
- USB setup pkt info entries
- Supply event entries

To print the Event log:

From the Diagnostics menu, navigate to **Event Log > Print Log**.

Clear Log

Use this to remove all the current information in the Event log. This affects both the viewed log and the printed log information.

To clear the event log:

1 From the Diagnostics menu, navigate to:

Event Log > Clear Log

2 Choose any of the following:

- Yes—To clear the Event log
- No—To exit the Clear log menu

Scanner tests

- [“ASIC Test” on page 256](#)
- [“Motor tests” on page 256](#)
- [“Feed test” on page 257](#)
- [“Sensor tests” on page 257](#)
- [“Scanner calibration reset” on page 260](#)
- [“ADF magnification” on page 260](#)

ASIC Test

This setting initiates a scan of the scanner ASIC’s memory.

To perform this test, do the following:

1 Navigate to **Scanner Tests > ASIC Test**.

2 The test executes. While this test executes, the screen displays **ASIC Test Running...** If the scanner ASIC passed the test, then the panel posts **ASIC Test Passed. Rebooting...** If the scanner ASIC failed the test, then the panel posts **ASIC Test Failed. Rebooting....**

Motor tests

ADF pick

When **Motor On** is selected, the device runs the pick motor continuously for five seconds and then automatically stops the motor.

To perform this test, do the following:

1 Navigate to **Scanner Tests > Motor Tests**.

2 Select **ADF pick**.

The test will run if it is working properly.

Flatbed scanner motor

When **Motor On** is selected, the device moves the flatbed scanner along the entire flatbed scanner path (that is, to the far wall and back to the Home position) and then automatically stops at the Home position.

To perform this test, do the following:

1 Navigate to **Scanner Tests > Motor Tests**.

2 Select **Flatbed Scanner Motor**.

The test will run.

ADF feed motor forward

When **Motor On** is selected, the device runs the motor forward continuously until **Motor Off** is selected.

To perform this test, do the following:

1 Navigate to **Scanner Tests > Motor Tests**.

2 Select **ADF Feed Motor Forward**.

The test will run.

ADF feed motor backward

When **Motor On** is selected, the device runs the motor forward continuously until **Motor Off** is selected.

To perform this test, do the following:

1 Navigate to **Scanner Tests > Motor Tests**.

2 Select **ADF Feed Motor Backward**.

The test will run.

Feed test

This test enables a servicer to execute a continuous feed test from either the ADF or the flatbed. The default is to perform the ADF test if paper is loaded into the ADF. To perform the Feed Test, do the following:

1 Navigate to **Diagnostic Menu > Scanner Tests > Feed Test**.

2 Press **Select a paper size**.

3 Select your paper size: A4 or Legal.

4 Select the check button on the screen. The screen displays **Feed Test passed** or **Feed Test failed**.

5 Press **X** on the keypad to exit the test.

Sensor tests

Sensor tests are available to test the sensors on the flatbed and ADF units.

The following sensors can be tested:

- ADF document set – Paper Present
- FB cover open (flatbed top cover)
- Home sensor (carriage home position)
- ADF interval sensor
- ADF stage skew (paper skew) - available on duplex scanners only
- ADF cover open (ADF top cover)

- Scan 1st sensor (paper feed sensor)
- Paper FB long

To test a flatbed or ADF sensor, perform the following steps:

- 1 Navigate to **Scanner Tests > Sensor Tests > <sensor to test>**. The following is displayed:

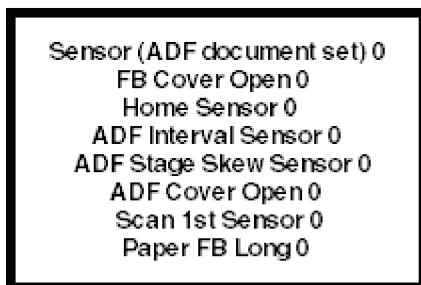

- 2 Select the sensor to be tested.

- 3 Actuate the sensor you selected.

The screen will toggle between 0 and 1 if the sensor is properly functioning.



- 4 Select **Exit** to leave the test.

To test the Paper FB long test, place a sheet of legal paper on the flatbed and close the cover. If the sensor is working properly, the indicator will change from 0 to 1.

To test the Home sensor, perform the following steps:

- 1 Exit the sensor test.
- 2 Open the flatbed cover.
- 3 Use the carriage motor test to move the carriage out of the home position.
- 4 Close the flatbed cover.
- 5 Enter the sensor test. If the home sensor is working properly, then a 1 will display instead of a 0.

A	Stage skew sensor (paper skew)	
B	Paper present	
C	Interval sensor	

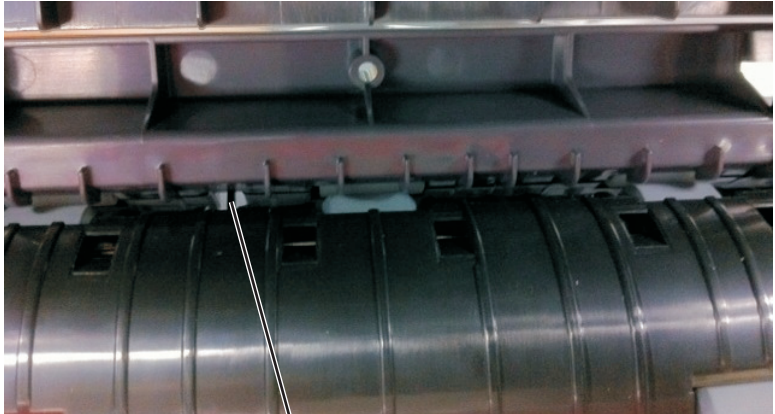
<p>D</p>	<p>ADF cover open</p>	 <p>A photograph showing the top of a scanner with the ADF cover open. A white arrow points from the letter 'D' at the bottom right to a specific component inside the scanner's lid.</p>
<p>E</p>	<p>Flatbed cover open</p>	 <p>A close-up photograph of the flatbed cover mechanism. A white arrow points from the letter 'E' at the bottom right to a small, dark, triangular-shaped component.</p>
<p>F</p>	<p>paper feed sensor</p>	 <p>A photograph of the paper feed rollers. A white arrow points from the letter 'F' at the bottom right to a small, light-colored sensor component mounted on the roller assembly.</p>

Scanner calibration reset

This test is run to reset the scanner calibration. This test should only be run after a flatbed or ADF unit has been replaced.

To perform this operation, do the following:

- 1 Navigate to **Scanner Tests**.
- 2 Select **Scanner Calibration Reset. This procedure should only be run after the scanner or ADF has been replaced** displays.
- 3 Ensure that the scanner glass and white flatbed cushion on the ADF are clean.
- 4 Select **Continue**. If the test is successful, then **Operation completed successfully** displays for three seconds, and then returns to the main Scanner Calibration Reset menu. If an error occurs during the test, then **Test Failed, Please Retry** displays, and a Continue button appears that takes you back to the main Scanner Calibration Rest Menu screen.
- 5 Select **Exit** to leave the test.

After successfully executing this test, verify the results.

- 1 Load the ADF with a document containing both light and dark content.
- 2 Perform a duplex copy. If the back side of the resulting copy contains vertical streaks, then the SE should clean the scanner glass and backing sheet, execute the back side scan uniformity procedure, and then perform another copy. If streaks still appear on the resulting copy, then the SE can repeat the cleaning and verification procedure a second time or can replace the ADF entirely.

ADF magnification

This test allows the service technician to adjust the ADF magnification level. To adjust the ADF magnification level, perform the following steps:

- 1 Navigate to **Diagnostic menu > Scanner Tests > ADF magnification**.
- 2 Use the plus or minus buttons to scroll through the magnification values. The values are 1.000, 1.005, 1.007, .980, .985, .990 and .995.
- 3 Press the check button to accept the value. Press **X** on the screen to exit the test.

Exit Diags

Select this to exit the Diagnostics menu. The printer performs a POR, and restarts in normal mode.

This menu appears as a soft button at the bottom right corner of the panel. This is always accessible to the user from the main Diagnostics menu.

Configuration menu

The Configuration menu group consists of menus, settings, and operations that are used to configure a printer for operation.

Entering the Configuration menu

- 1 Turn off the printer.
- 2 Press and hold **2** and **6** while turning on the printer.
Release the buttons when the splash screen appears.

Reset ADF Maintenance Kit Counter

After scheduled maintenance, the ADF maintenance count value must be reset to zero.

To reset the maintenance count value to zero:

- 1 From the Configuration menu, navigate to **Reset ADF Maintenance Kit Counter**.
- 2 Touch **reset separator roll and pick assembly counter**. **Resetting** displays.
- 3 Touch **back** to exit.

Maintenance Counter Value

When this is selected, the printer displays the current value for the maintenance kit counter. This counter tracks printer usage. A print job containing a single page increments the counter by one, while a duplex print job increments the counter by two. When the value has reached the rated life of the maintenance kit, it reminds the user that scheduled maintenance is required. See [“Maintenance kits” on page 480](#). The counter must be reset after the maintenance kit is installed.

To view the maintenance counter value:

- 1 From the Configuration menu, navigate to **Maintenance Counter Value**.
The value is displayed and cannot be changed.
- 2 Press **Back** or **X** to return to the Configuration menu.

Reset Maintenance Counter

After installing the maintenance kit, the maintenance counter must be reset.

To reset the maintenance counter:

- 1 From the Configuration menu, navigate to **Reset Maintenance Counter**.
- 2 Depending on the printer model, press **OK** or touch  to reset the counter, or press **X** to exit without resetting the counter.

Once initiated, the operation cannot be canceled.

Print Quality Pages

This option is a limited version of the Print quality pages setting that appears in the Diagnostics menu. See [“Print Quality Pages” on page 242](#). This setting reports the values of a broad range of printer settings and tests the ability of the printer to generate acceptable printed output.

To print the report:

- 1 From the Configuration menu, navigate to **Print Quality Pages**.
- 2 Depending on the printer model, press **OK** or touch  to print the pages, or press **X** to exit without printing the pages.
Printing Quality Test Pages appears on the display. Once started, the printing cannot be canceled and no buttons are active until the printing completes.

Reports

Menu Settings Page

This report generates a list of the Configuration menu settings and the value of each setting.

To print the Menu settings page from the Configuration menu:

- 1 From the Configuration menu, navigate to:
Reports > Menu Settings Page
- 2 Depending on the printer model, press **OK** or touch  to print the page, or press **X** to return to the Configuration menu.

Event Log

This generates a printed report of the events detailed in the Print log. See [“Print Log” on page 255](#).

To print the Event log from the Configuration menu:

- 1 From the Configuration menu, navigate to:
Reports > Event Log
- 2 Press **X** to return to the Configuration menu.

Panel Menu

The Panel Menu lets the system support person enable or disable the control panel menus. Selecting **On** (the default) allows users to change values for the printer. **Off** disables the users' access to menus. If a user presses **Menu**, then they receive a message that the panel menus are locked. When set to **Off**, this setting restricts all menu access, even to menus or items set for PIN access. However, when set to **On**, all PIN restrictions are restored.

This menu item appears only when the PJI PASSWORD Environment variable is set to 0.

PPDS Emulation

The value of this option determines if a printer can recognize and use the PPDS data stream.

Available options:

- Deactivate
- Activate

Download Emuls

This appears only if at least one download emulator (DLE) is installed. The default setting is Disable. All download emulators (DLEs) are reenabled automatically after two PORs.

Safe Mode

The settings for this menu item are On and Off (default). When enabled, Safe Mode lets the printer operate in a special limited mode in which it attempts to continue offering as much functionality as possible despite known issues. For more information about Safe Mode and the Safe Mode print behavior for this model, see [“Using Safe Mode” on page 46](#).

To change the setting:

- 1 From the Configuration menu, navigate to **Safe Mode**.
- 2 Select **On** or **Off** to change the setting.
- 3 Select **Submit**.
- 4 POR the printer.

Factory Defaults

Warning—Potential Damage: This operation cannot be undone.

This setting enables a user to restore all of the printer settings to either the network settings (on network models only) or to the base printer settings.

To restore Factory Default settings:

- 1 From the Configuration Menu, navigate to **Factory Defaults**.
- 2 Select from the available options:
 - Restore Base—restores all non-critical base printer NVRAM settings.
 - Restore STD Net—restores all network NVRAM settings.
 - Restore LES (available on the touch screen models only)—restores the factory default values for all framework, standard applications and eSF configuration by removing all non-standard applications; and clears the SE logs.

After this setting is changed, the device automatically performs a POR, and restores the appropriate settings to their factory default values.

Energy Conserve

This setting controls which values appear on the Power Saver menu.

To change the setting:

- 1 From the Configuration menu, navigate to **Energy Conserve**.
- 2 Select **On** or **Off**.

If On (default), then the Sleep Mode cannot be turned off. If Off, then **Disabled** appears on the Sleep Mode menu, and it can be turned off.

Fax low power support

Fax Low Power support allows you to select one of three power settings for the fax. The Auto value relies on the firmware's logic to determine if the device supports the fax portion of the low power architecture. Permit Sleep allows the fax chip to enter low power mode whenever the device determines that it should. Disable Sleep prohibits the fax chip from ever entering low power mode.

To change the fax low power support setting:

- 1 Select **Fax low-power support** in the configuration menu to open the item
- 2 Select one of the three settings: disable, sleep permit, or sleep auto.
- 3 Select  to accept the setting, or press the **X** on the screen to exit the item.

Min copy memory

Values will be displayed only if the amount of installed DRAM is at least twice the amount of the value, that is, at least 200 MB of installed DRAM is required to display the 100 MB selection.

To change this setting:

- 1 Select **Min Copy Memory** from the Configuration Menu. [**setting's current value**] displays.
- 2 Select the desired setting from the following values: 25, 35, 50, 80, 100.
- 3 Select **Submit** to save the change.

Num pad job assist

This setting determines if a user can configure and initiate a job using the control panel's hard buttons.

To change this setting:

- 1 Select **Num Pad Job Assist** from the Configuration Menu. [**setting's current value**] displays.
- 2 Select the minus to decrease the setting's value or the plus to increase the setting's value.
- 3 Select **Submit** to save the change.

Format fax storage

This setting enables you to format the non-volatile storage used for storing faxes.

To change this setting:

- 1 Select **Format Fax Storage** from the Configuration Menu.

Note: If an advanced password has been established, then you must enter this password to change the setting. If no advanced password exists, then you can establish one by using the keyboard that appears on the LCD.

- 2 Select **Submit** to save the change.
- 3 Select **Back** to cancel and return to the Configuration Menu. **Formatting Fax Flash DO NOT POWER OFF** appears on the display while the format operation is active.

ADF edge erase

This menu item sets the size, in millimeters, of the no-print area around an ADF scan job. All copy jobs have a minimum of a two millimeter border. Copy jobs will use the setting or two millimeters, whichever is larger.

To adjust the ADF edge erase setting, perform the following steps:

- 1 Select **ADF Edge Erase** from the Configuration Menu. **[setting's current value]** displays.
- 2 Select minus to decrease the setting's value or plus to increase the setting's value.
- 3 Select **Submit** to save the change.
- 4 Select **Back** to cancel and return to the Configuration Menu.

Flatbed edge erase

This menu item sets the size, in millimeters, of the no print area around a flatbed scan job. Copy jobs will use the setting or two millimeters, whichever is larger.

To adjust the flatbed edge erase setting, perform the following steps:

- 1 Select **FB Edge Erase** from the Configuration Menu. **[setting's current value]** displays.
- 2 Select minus to decrease the setting's value or plus to increase the setting's value.
- 3 Select **Submit** to save the change.
- 4 Select **Back** to cancel and return to the Configuration Menu.

Scanner manual registration

This item is used to manually register the flatbed and ADF on the MFP scanner unit. Registration should be performed whenever the ADF unit, flatbed unit, or controller card are replaced.

To manually register a Duplex ADF, perform the following steps:

- 1 In the Configuration Menu, scroll to the Scanner Manual Registration menu item.
- 2 Select **Scanner Manual Registration**.
- 3 Select **Print Quick Test Page**.

- 4 To view and adjust the duplex ADF front side registration, place the quick test page faceup into the ADF.
- 5 Select **Copy Quick Test**.
- 6 After the quick test page copies, select **ADF Front**.
- 7 Use the plus to increase or the minus to decrease the settings value for horizontal adjust and top margin.
Note: Each button press moves the margin values one pixel in the respective direction.
- 8 Select **Submit** to accept the value.
- 9 Save changes by placing the print quick test page face up and selecting **Copy Quick Test**.
- 10 Repeat steps 6, 7, and 8 as needed.
- 11 To view and adjust the duplex ADF backside registration, place the quick test page face down up into the ADF, and select **Copy Quick Test**.
- 12 After the quick test page copies, select **ADF Back**.
- 13 Use the plus or minus to increase or decrease the settings value for horizontal adjust and top margin.
Note: Each button press moves the margin values one pixel in the respective direction.
- 14 Select **Submit** to accept the value.
- 15 Verify the changes by placing the print quick test page face down and selecting **Copy Quick Test**.
- 16 Repeat steps 13, 14, and 15 as needed.

To manually register the flatbed, perform the following steps:

- 1 In the Configuration Menu, select the Scanner Manual Registration menu item.
- 2 Select the Print Quick Test Page menu item.
- 3 To view and adjust the flatbed registration, place the quick test page into the flatbed.
- 4 Select the Copy Quick Test Page item.
- 5 After the quick test page copies, select **Flatbed**.
- 6 Use the plus or minus to increase or decrease the settings value for the left or top margin.
Note: Each button press moves the margin values one pixel in the respective direction.
- 7 Select **Submit** to accept the value.
- 8 Place the print quick test page on the flatbed and select **Copy Quick Test**.
- 9 Repeat steps 5 and 6 as needed.
- 10 To exit REGISTRATION, select **Back** or **Stop**.

Disable scanner

This menu item is used to disable the MFP scanner if it is malfunctioning. The MFP must be powered off and on for the new settings to take effect.

To change this setting:

- 1 Select **Disable Scanner** from the Configuration menu.
- 2 Scroll through the setting's other possible values. The values are Enable, Disable, ADF disable.
- 3 To save the setting's new value, select **Submit**.

Paper Prompts

This controls which tray a change prompt is directed to when paper is sensed to be the wrong size.

Note: The value of [“Action for Prompts” on page 268](#) may override the value of this setting.

To change this setting:

- 1 From the Configuration menu, navigate to **Paper Prompts**.
- 2 Select from the available options:
 - Auto (default)
 - Multi-purpose Feeder
 - Manual Paper
- 3 Depending on the printer model, press **OK** or touch  to save the setting, or press **X** to return to the Configuration menu without saving any changes.

When it is set to **Auto**, the emulator selected to print the job determines which of the installed input sources will receive the change prompt. When set to a value other than Auto, the selected source always receives this type of prompt.

Envelope Prompts

This controls which tray a change prompt is directed to when the envelopes are sensed to be the wrong size.

Note: The value of [“Action for Prompts” on page 268](#) may override the value of this setting.

To change this setting:

- 1 From the Configuration menu, navigate to **Envelope Prompts**.
- 2 Select from the available options:
 - Auto (default)
 - Multi-purpose Feeder
 - Manual Envelope
- 3 Depending on the printer model, press **OK** or touch  to save the setting, or press **X** to return to the Configuration menu without saving any changes.

When it is set to **Auto**, the emulator selected to print the job determines which of the installed input sources will receive the change prompt. When set to a value other than Auto, the selected source always receives this type of prompt.

Action for Prompts

This setting enables a user to determine which input source would receive paper-related or envelope-related change prompts when they occur. Regardless of the target source, the printer always requires some type of user assistance to resolve the change prompt (examples: pushing a button to ignore the prompt and changing the source's installed media). However, this setting gives a user the option of having the printer resolve change prompt situations without requiring any user assistance.

To change this setting:

- 1 From the Configuration menu, navigate to **Action for Prompts**.
- 2 Select from the available options to change the setting.
 - Prompt User (default)
 - Continue
 - Use Current
- 3 Depending on the printer model, press **OK** or touch  to save the setting, or press **X** to return to the Configuration menu without saving any changes.

When set to **Prompt user**, the printer behaves like the past implementation. When a change prompt occurs, the printer stops printing, posts the change prompt to the target source, and waits for the user to select an action before continuing.

When set to **Continue**, the printer automatically assumes that the user selects **Continue** every time a change prompt is encountered. Likewise, when the device is set to **Use Current**, all change prompts will perform as if **Use Current** was selected by the user.

Jobs on Disk

This setting appears only if a hard disk is installed. It allows buffered jobs to be deleted from the disk. This does not affect Print and Hold or parked jobs.

To change the setting:

- 1 From the Configuration menu, navigate to **Jobs on Disk**.
- 2 Select from the available options to change the setting:
 - Delete
 - Do Not Delete (default)
- 3 Press **X** to return to the Configuration menu.

Disk Encryption

Warning—Potential Damage: If the settings are changed, then the printer completely formats the hard disk. All information on the disk will be unrecoverable.

This setting appears only if a hard disk is installed. It controls whether the printer encrypts the information that it writes to the hard disk.

To change the setting:

- 1 From the Configuration menu, navigate to **Disk Encryption**.
- 2 Select from the available options to change the setting.
 - Enable—enables encryption of hard disk.
 - Disable (default)—enables formatting of hard disk.
- 3 **Contents will be lost. Continue?** appears. Select **Yes** to proceed with the encryption or formatting of the disk, or **No** to cancel the operation. If Yes is selected, then a progress bar appears on the display that indicates the overall completion of the selected operation. After completion, the display returns to Disk Encryption.

Wipe All Settings

This makes any sensitive information that may exist on the volatile or non-volatile storage of the device completely indecipherable. When selected, the printer performs a non-critical NVRAM reset and then reboots.

Font Density

This creates microscopic holes in all black text. The holes save toner by reducing overlapping toner.

Available options: 1 to 5

Font Sharpening

This allows a user to set a text point-size value below which the high-frequency screens will be used when printing font data.

Available options:

- Off
- On

Reduced Curl

When on, this setting significantly reduces throughput and should be activated only as a last resort to solve paper curl problems. The printer uses this mode only when the media type is set to Paper.

Available options:

- Off
- On

Require Standby

This sets Standby Mode to On or Off. The default is On.

To change the setting:

- 1 From the Configuration menu, navigate to **Require Standby**.
- 2 Select **On** or **Off** to change the setting.
- 3 Depending on the printer model, press **OK** or touch  to save the setting, or press **X** to return to the Configuration menu without saving any changes.

If Standby mode is On, the printer begins functioning in Standby mode when it remains idle for an amount of time.

The Standby mode enables the printer:

- To consume less energy than when operating in normal mode but not as little as when operating in Power saver.
- To return to the Ready state more quickly than when operating in power saver. If set to Off, this setting disables Standby mode in the General settings menu.

A5 Loading

This determines the orientation used when printing on A5 paper.

Available options:

- Long Edge—The printer will print A5-size paper in the long-edge feed orientation from all trays.
- Short Edge—The printer will print A5-size paper in the short-edge feed orientation from all trays.

UI Automation

Once enabled, this setting creates an **ENABLE_UI_AUTOMATION** file in the `/var/fs/shared/` directory. As long as this file exists, the printer permits external developers to test the stability of their applications against the printer to make sure that their applications have an appropriate level of stability. Disabling this setting deletes the file and prohibits automated testing.

To change the setting:

- 1 From the Configuration menu, navigate to **UI Automation**.
- 2 Select from the available options to change the setting.
 - Enable
 - Disable (default)
- 3 Depending on the printer model, press **OK** or touch  to save the setting, or press **X** to return to the Configuration menu without saving any changes.

LES Applications

Note: This setting is for touch-screen models only.

This menu setting is used to enable or disable Lexmark Embedded Solutions (LES) applications. This setting does not affect built-in applications.

To change the settings, perform the following steps:

- 1 From the Configuration menu, navigate to **LES applications**.
- 2 Press the left or right arrow to navigate, then select **Enable** or **Disable**.
- 3 Touch **Submit**.

Press **Back** to return to the Configuration menu.

Key Repeat Initial Delay

Note: This setting is available only on the MS610de model.

This setting determines the length of delay before a repeating key starts repeating. The range is 0.25–5 seconds, with increments of 0.25. The default setting is one second.

To adjust this setting:

- 1 From the Configuration menu, navigate to **Key Repeat Initial Delay**.
- 2 Touch the arrow keys to adjust the setting.
- 3 Touch  to save the setting, or press **X** to return to the Configuration menu without saving any changes.

Key Repeat Rate

Note: This setting is available for touch screen models only.

This setting indicates the number of presses per second for repeating keys. The range is 0.5–30, with increments of 1.

To adjust this setting:

- 1 From the Configuration Menu, navigate to **Key Repeat Rate**.
- 2 Touch the arrow keys to adjust the setting.
- 3 Touch  to save the setting, or press **X** to return to the Configuration Menu without saving any changes.

Clear Supply Usage History

This setting reverts the supply usage history (number of pages and days remaining) to the factory shipped level.

To clear the supply usage history:

- 1 From the Configuration menu, navigate to **Clear Supply Usage History**.
- 2 Depending on the printer model, press **OK** or touch **Clear Supply Usage History** to proceed.

Clear Custom Status

Executing this operation erases any strings that have been defined by the user for the default or alternate custom messages.

To clear the custom status:

- 1 From the Configuration menu, navigate to **Clear Custom Status**.
- 2 Depending on the printer model, press **OK** or touch **Clear Custom Status** to proceed.

USB Speed

This setting is used to set the throughput of the USB port on the printer.

Available options:

- Auto
- Full—Forces the USB port to run at full speed and also disables its high-speed capabilities.

Automatically Display Error Screens

If On, the panel automatically displays any existing printer-related IR after the printer remains inactive on the home screen for a length of time equal to the Screen timeout setting in the Timeouts section of the General settings menu. Any IR that appears on the display will give the user the option of returning to the home screen without clearing it. From the home screen, any other workflow or feature can be initiated as usual. Once the printer returns to the home screen, any existing IR will again appear after the printer remains inactive for a length of time equal to the Screen timeout setting.

To change this setting:

- 1 From the Configuration menu, navigate to **Automatically Display Error Screens**.
- 2 Select from the available options:
 - On (default)
 - Off
- 3 Depending on the printer model, press **OK** or touch  to save the setting, or press **X** to return to the Configuration menu without saving any changes.

USB PnP

In some cases, the USB port at the back of the printer may be incompatible with the chipset in a user's PC. This setting lets the user change the USB driver mode to improve its compatibility with these PCs.

Available options:

- 1
- 2

Restore factory defaults

Restore Settings

This setting enables a user to restore all of the printer settings to either the network settings (on network models only) or to the base printer settings.

To restore the settings:

- 1 From the Configuration menu, navigate to **Restore Factory Defaults > Restore Settings**.
- 2 Select from the available options:
 - Restore Printer Settings—restores all non-critical base printer NVRAM settings.
 - Restore Network Settings—restores all network NVRAM settings.
 - Restore Apps—restores the factory default eSF configuration.

Erase Printer Memory

This makes any sensitive information that may exist on the volatile or non-volatile storage of the device completely indecipherable. When selected, the printer performs a non-critical NVRAM reset and then reboots.

Erase Hard Disk

This setting performs a wipe of the printer hard disk, erasing all data.

Warning—Potential Damage: This deletes all data on the printer hard disk, including downloaded fonts, macros, and held jobs. Do not initiate a disk wipe if you have information on the printer that you want to save.

Available options:

- Single Pass Erase—overwrites all data and the file system. This wipe is faster but less secure since it is possible to retrieve the deleted data with forensic data-retrieval techniques.
- Multi Pass Erase—overwrites all data without rewriting the file system. This wipe is DoD 5220.22-M compliant since the deleted data is irretrievable.

Note: If the printer is reset while a disk wipe operation is executing, then **Corrupt Disk** appears upon regaining power.

Entering Invalid engine mode

This mode allows the printer to load the correct firmware code.

- 1 Turn off the printer.
- 2 From the control panel, press and hold the **3**, **4**, and **6** while turning on the printer.
- 3 Release the buttons after 10 seconds.

Entering Recovery mode

This mode allows the printer to boot from a secondary set of instructions and flash firmware code. While in this mode, you can only flash firmware code through a USB cable directly connected to a PC.

Depending on your printer model, do any of the following:

For LED display

- 1 Turn off the printer.
- 2 Open the front door.
- 3 Press and hold the **Stop** button.
- 4 Turn on the printer.
- 5 When all the icons flash, release the button.

For 2-line display

- 1 Turn off the printer.
- 2 Press and hold the **OK** and **Back** buttons.
- 3 Turn on the printer.
- 4 When the display shows the following icon, release the buttons.

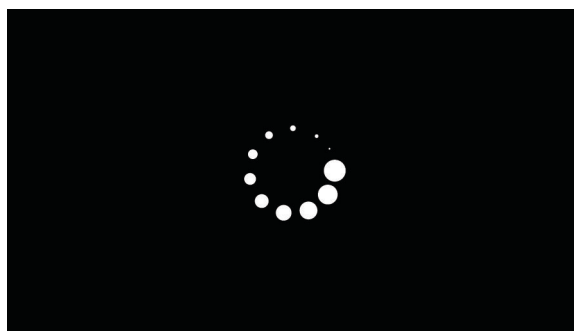

For 2.4-, 4.3-, 7-, and 10-inch displays with number pads

- 1 Turn off the printer.
- 2 Press and hold the **2**, **7**, and **8** buttons.
- 3 Turn on the printer.

- 4 When the display shows the following icon, release the buttons.

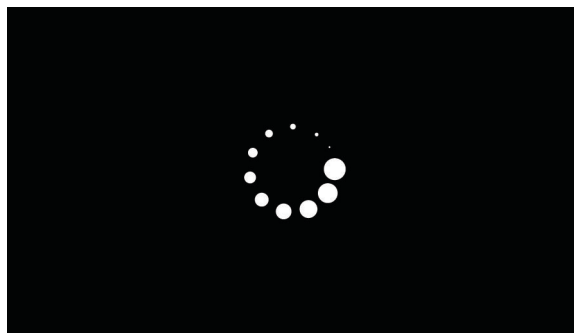

For 2.8-, 4.3-, 7-, and 10-inch displays without number pads

- 1 Turn off the printer.
- 2 Open tray 1.
 - Note:** Make sure that paper is loaded in the tray.
- 3 Turn on the printer.
- 4 When an ellipses appears on the upper-left corner of the display, close tray 1.
 - Note:** If tray 1 is not closed, then the printer boots normally.

Accessing restore point

Note: This functionality is available for 4.3", 7" and 10" display printers only.

This functionality allows the printer firmware to roll back to a previous state whenever a firmware update causes problems in the printer.

Notes:

- A restore point is generated when a new firmware code is flashed. Only one restore point is saved.
 - If the printer is new, then there are no existing restore points and the key sequence is ignored.
- 1 Turn off the printer.
 - 2 Press and hold the **7** and **8** buttons simultaneously.
 - 3 Turn on the printer.
 - 4 Release the buttons when a splash screen appears.

Accessing the Network SE menu

This menu contains settings for fine tuning the communication settings for the network interfaces and protocols.

- 1 Navigate to:
 - Networks/Ports > Standard Network > Standard Network Setup.**
- 2 Press and hold **6**, **7**, and **9** simultaneously.

Service Engineer menu

Accessing the service engineer (SE) menu

From a Web browser on a host PC, add `/se` to the printer IP address.

Service engineer (SE) menu

This menu should be used as directed by the next level of support.

Top level menu	Intermediate menu
Print SE Menus	
General	Copyright — Displays copyright information
Code Revision Info	<ul style="list-style-type: none"> • Network code level — Displays network code level • Network Compile Info — Displays network compile information • Printer Code Level — Displays printer code information • Printer Compile Info — Displays compile information
History	<ul style="list-style-type: none"> • Print History • Mark History • History Mode
MAC	<ul style="list-style-type: none"> • Set Card Speed • LAA • Keep Alive
NVRAM	<ul style="list-style-type: none"> • Dump NVRAM • Reinit NVRAM
TCP/IP	<ul style="list-style-type: none"> • netstat-r • arp-a • Allow SNMP Set • MTU • Meditech Mode • RAW LPR Mode • Gather Debug • Enable Debug

Fax service engineer (SE) menu

The Fax SE menu is used for the Fax transmission service check and the Fax reception service check. It should only be used as directed by the next level of support.

In Ready mode, type ****411** to enter the Fax SE menu.

Parts removal

- [“Removal precautions” on page 277](#)
- [“Removal procedures” on page 302](#)
- [“Left side removals” on page 302](#)
- [“Right side removals” on page 315](#)
- [“Front side removals” on page 327](#)
- [“Bottom side removals” on page 361](#)
- [“Rear side removals” on page 381](#)
- [“Top side removals” on page 391](#)
- [“ADF/scanner removals” on page 399](#)
- [“550-sheet option tray removals” on page 415](#)
- [“Staple finisher option removals” on page 421](#)

Removal precautions

 **CAUTION—SHOCK HAZARD:** For personal safety and to prevent damage to the printer, remove the power cord from the electrical outlet before you connect or disconnect any cable, electronic board, or assembly. Disconnect any connections between the printer and the PCs/peripherals.

Data security notice

- 1 This printer contains various types of memory that are capable of storing device and network settings, information from embedded solutions, and user data. The types of memory, along with the types of data stored by each, are described below.
 - **Volatile memory**—This device utilizes standard Random Access Memory (RAM) to temporarily buffer user data during simple print and copy jobs.
 - **Non-volatile memory**—This device may utilize two forms of non-volatile memory: EEPROM and NAND (flash memory). Both types are used to store the operating system, device settings, network information, scanner and bookmark settings, and embedded solutions.
 - **Hard disk memory**—Some devices have a hard disk drive installed. The printer hard disk is designed for device-specific functionality and cannot be used for long term storage for data that is not print-related. The hard disk does not provide the capability for users to extract information, create folders, create disk or network file shares, or transfer FTP information directly from a client device. The hard disk can retain buffered user data from complex print jobs, as well as form data and font data.

To erase volatile memory, turn off the printer.

To erase non-volatile memory, see the menu item under [“Configuration menu” on page 261](#) pertaining to this.

To erase the printer hard disk, see the menu item under [“Configuration menu” on page 261](#) pertaining to this.

The following parts are capable of storing memory:

- printer control panel
- UICC (User Interface Controller Card)

- controller board
- optional hard drives

Note: The printer control panel and controller board contain NVRAM.

2 After removing the old part, it must be returned to your next level of support.

Handling ESD-sensitive parts

Many electronic products use parts that are known to be sensitive to electrostatic discharge (ESD). To prevent damage to ESD-sensitive parts, use the following instructions in addition to all the usual precautions, such as turning off power before removing logic boards:

- Keep the ESD-sensitive part in its original shipping container (a special “ESD bag”) until you are ready to install the part into the machine.
- Make the least-possible movements with your body to prevent an increase of static electricity from clothing fibers, carpets, and furniture.
- Put the ESD wrist strap on your wrist. Connect the wrist band to the system ground point. This discharges any static electricity in your body to the machine.
- Hold the ESD-sensitive part by its edge connector shroud (cover); do not touch its pins. If you are removing a pluggable module, use the correct tool.
- Do not place the ESD-sensitive part on the machine cover or on a metal table; if you need to put down the ESD-sensitive part for any reason, first put it into its special bag.
- Machine covers and metal tables are electrical grounds. They increase the risk of damage, because they make a discharge path from your body through the ESD-sensitive part. (Large metal objects can be discharge paths without being grounded.)
- Prevent ESD-sensitive parts from being accidentally touched by other personnel. Install machine covers when you are not working on the machine, and do not put unprotected ESD-sensitive parts on a table.
- If possible, keep all ESD-sensitive parts in a grounded metal cabinet (case).
- Be extra careful while working with ESD-sensitive parts when cold-weather heating is used, because low humidity increases static electricity.

Controller board/control panel replacement

This procedure should be followed only if both the controller board and the control panel fail. If you need to replace only one of the FRUs, follow the startup procedure described in the FRU’s removal procedure.



CAUTION—POTENTIAL INJURY

The lithium battery in this product is not intended to be replaced. There is a danger of explosion if a lithium battery is incorrectly replaced. Do not recharge, disassemble, or incinerate a lithium battery. Discard used lithium batteries according to the manufacturer’s instructions and local regulations.

Warning—Potential Damage: If the control panel and the controller board are being replaced at the same time, replace the parts in this order to avoid damage to the machine.

1 Replace the controller board first.

Note: Do not replace the new control panel and controller board in the machine at the same time.

2 After installing the new controller board, and before installing the new control panel, start the printer into diagnostics mode.

- 3 After the printer has completed startup, turn off the printer and replace the control panel.
Note: If the control panel display has failed, the printers' startup cycle is complete when the driver motor and fans shut down, and the machine is quiet.
- 4 After installing the new control panel, start the printer into diagnostics mode, and allow the printer to go through a complete startup cycle and the display to go to Ready.
- 5 If the problems persist, leave the new control panel in the machine, place the old controller board back in the machine, and start it up. After the machine startup, shut down the machine, and install the new controller board. After installing the new controller board, restart the machine, and let it go through the startup cycle.

After this procedure is completed successfully, there is no need to adjust any settings.

If the above procedure fails, you must contact the technical support center for further instructions.

Restoring the printer configuration after replacing the controller board

Restore the printer to its correct configuration to complete the replacement service. Use the Service Restore Tool to download the software bundle, and then flash the printer settings and embedded solutions.

Note: The software bundle contains the latest version of the firmware, applications, and software licenses from the Lexmark Virtual Solutions Center (VSC). The printer firmware may be at a different level from what was used before replacing the controller board.

Using the Service Restore Tool

- 1 Go to <https://cdp.lexmark.com/service-restore-tool/> to access the tool.
- 2 Log in using your Lexmark or partner login.
If your login fails, then contact your next level of support.
- 3 Enter the printer serial number, and then submit the information.

The screenshot shows the Lexmark Service Restore Tool web interface. At the top, the Lexmark logo is on the left, and a user greeting 'Welcome, test support' with a 'Sign out' link is on the right. The main content area has a dark blue header with the text 'Service Restore Tool'. Below this, there is a light gray box containing the text 'Service Restore Tool' and a form. The form has a text input field with the placeholder text 'Enter serial number of device to restore' and a blue button labeled 'SUBMIT'.

Note: Make sure that the serial number that appears on the verification screen is correct.

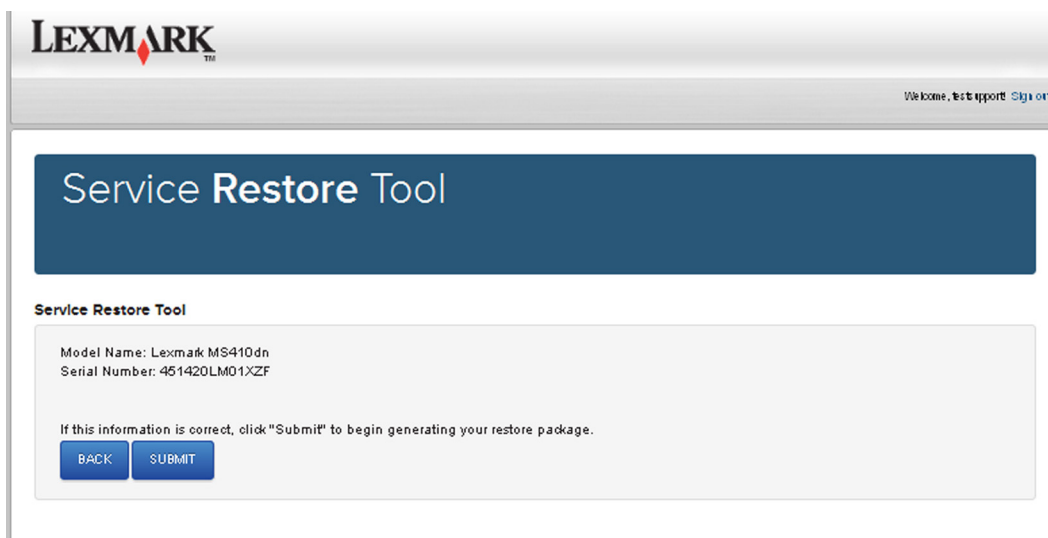

4 Save the zip file.

Note: Make sure that the serial number in the zip file matches the serial number of the printer being restored.

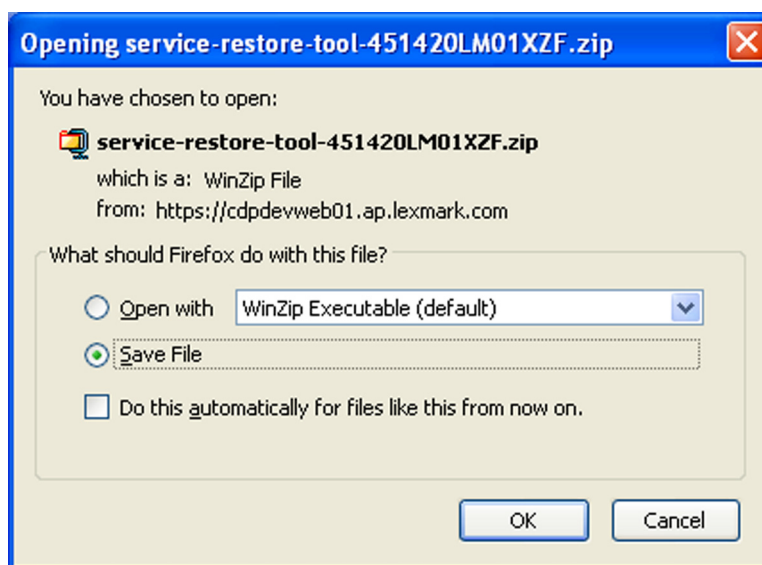

5 Extract the contents of the zip file, open the *Readme* file, and then follow the instructions in the file.

Notes:

- Perform the install instructions on the *Readme* file in the exact order shown. Restart the printer only if the file says so.
- For more information on how to flash the downloaded files, see [“Updating the printer firmware” on page 283](#).
- To load the zip files that are extracted from the Service Restore Tool, see [“Restoring solutions, licenses, and configuration settings” on page 282](#).

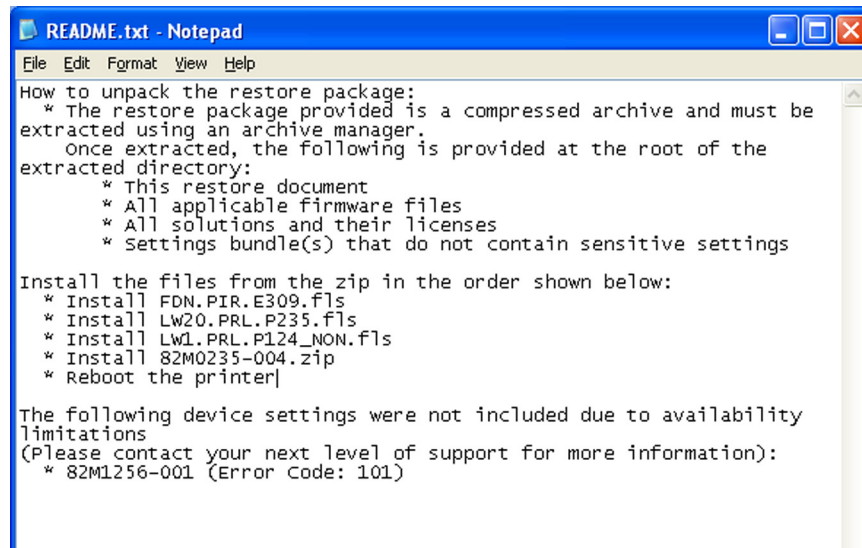

```

README.txt - Notepad
File Edit Format View Help
How to unpack the restore package:
* The restore package provided is a compressed archive and must be
extracted using an archive manager.
  once extracted, the following is provided at the root of the
extracted directory:
  * This restore document
  * All applicable firmware files
  * All solutions and their licenses
  * Settings bundle(s) that do not contain sensitive settings

Install the files from the zip in the order shown below:
* Install FDN.PIR.E309.fls
* Install Lw20.PRL.P235.fls
* Install Lw1.PRL.P124_NON.fls
* Install 82M0235-004.zip
* Reboot the printer]

The following device settings were not included due to availability
limitations
(Please contact your next level of support for more information):
* 82M1256-001 (Error Code: 101)

```

- 6 After performing the installation instructions in the *Readme* file, confirm from the customer if all the eSF apps have been installed.

Notes:

- If you are unable to access the administrative menus to verify that the printer is restored, then ask the customer for access rights.
- If a 10.00 error appears after you restart the printer, then contact the next level of support.

Restoring solutions, licenses, and configuration settings

To load the zip files that are extracted from the Service Restore Tool, do the following:

- 1 Open a Web browser, and then type the printer IP address.
- 2 Navigate to **Settings > Configuration Files**.

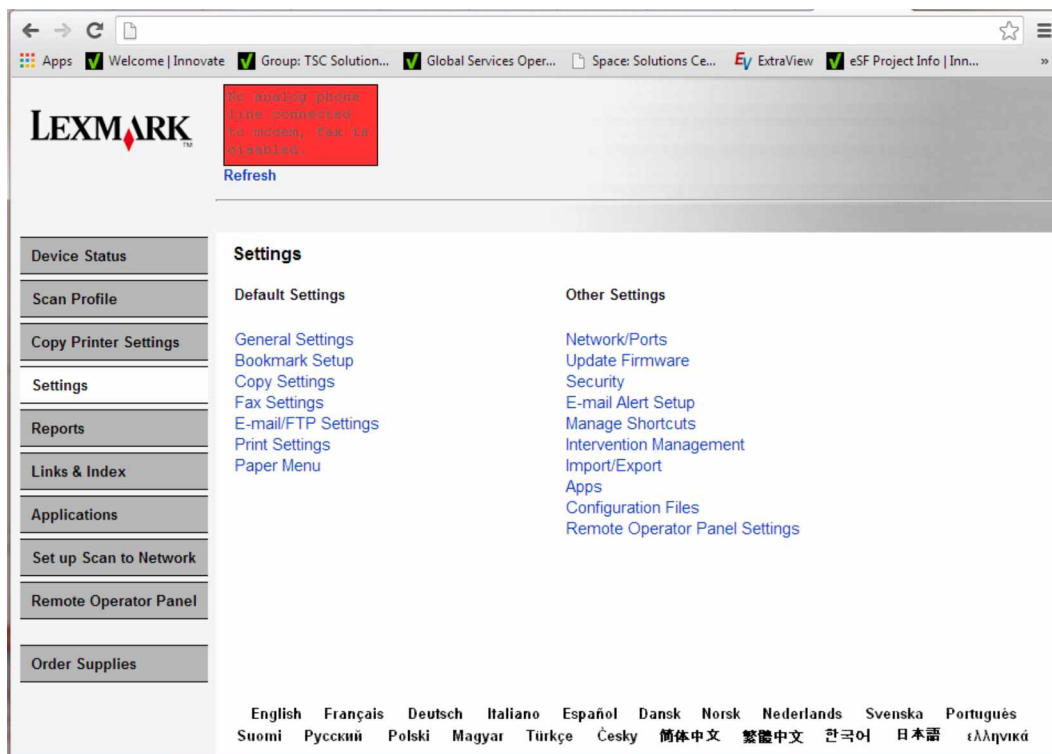

- 3 From the Configuration File History tab, navigate to **Import > Choose File**.
- 4 Select the zip file from the expanded Service Restore Tool package.

5 Click **Import**.

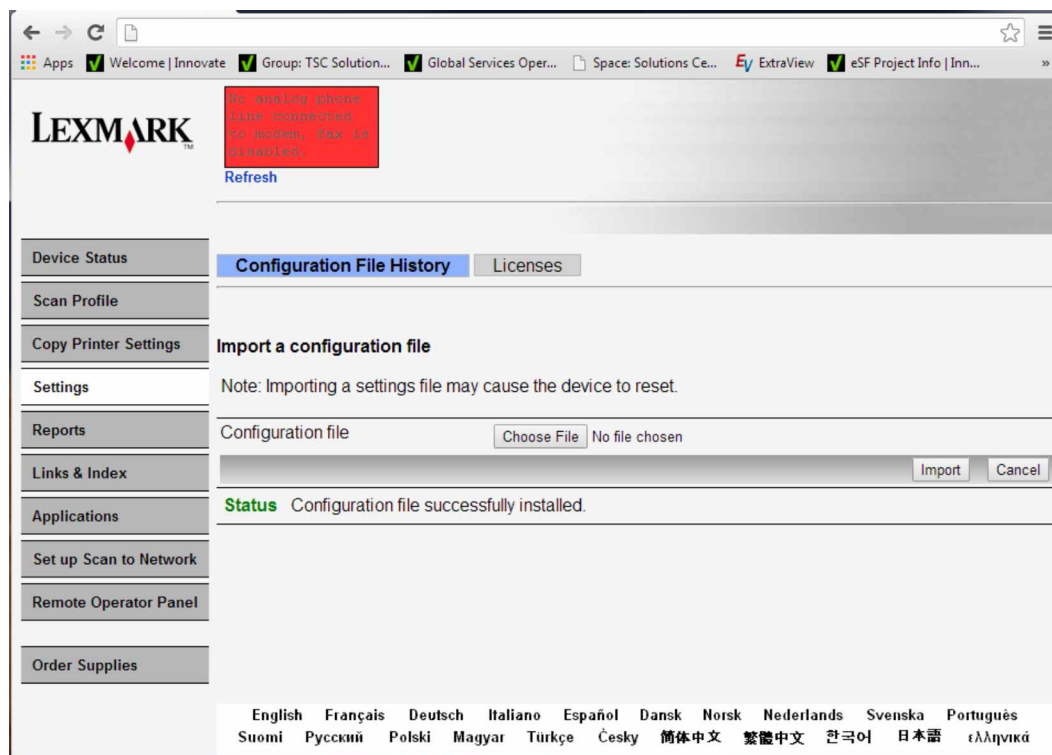

6 Repeat steps 3 through 5 for the other zip files that are included in the expanded zip file.

Updating the printer firmware

Warning—Potential Damage: Before updating the printer firmware, ask the next level of support for the correct code. Using an incorrect code level may damage the printer.

The printer must be in ready state in order to update the firmware.

Using a flash drive

This option is available only in printer models with front USB port.

Make sure to enable the Enable Drive and Update Code settings. You can find the settings in the Flash drive menu under the Settings menu.

- 1 Insert the flash drive into the USB port.
- 2 From the control panel, navigate to **USB Menu: Print from USB > Accept** or **OK**.
- 3 Select the file that you need to flash.

Note: Do not turn off the printer while the update is going on.

Using a network computer

Using the File Transfer Protocol (FTP)

Make sure that the printer is in ready state before flashing the printer.

- 1 Turn on the printer.
- 2 Obtain the IP address:
 - From the home screen
 - From the TCP/IP section of the Network/Ports menu
- 3 From the command prompt of a network computer, open an FTP session to the printer IP address.
- 4 Use a PUT command to place the firmware file on the printer.
The printer performs a POR sequence and terminates the FTP session.
- 5 Repeat step 2 through step 4 for the other files.

Using the Embedded Web Server

Make sure that the printer is in ready state before flashing the printer.

- 1 Open a web browser, and then type the printer IP address.
- 2 From the home page, navigate to **Configuration > Update Firmware**.
- 3 Select the file to use.
The printer performs a POR sequence and terminates the FTP session.
- 4 Repeat step 2 through step 4 for the other files.

Backing up eSF solutions and settings

Note: Export the eSF solutions and settings from the printer before replacing the controller board.

Exporting eSF solutions and settings file

- 1 Reset the printer into Invalid engine mode. See [“Entering Invalid engine mode” on page 273](#).
- 2 Open a web browser, and then type the printer IP address.
Note: If the web page cannot be accessed or an error occurs when starting the printer into Invalid engine mode, then data backup is not an option. Inform the customer that the data cannot be saved.
- 3 Navigate to **Settings > Solutions > Embedded Solutions**.
- 4 From the Embedded Solutions page, select the applications that you want to export.
- 5 Click **Export**.
Note: The size limit of the export file is 128 KB.

Importing eSF solutions and settings file

After replacing the controller board, import back to the printer the eSF solutions and settings that were exported.

- 1 Reset the printer into Invalid engine mode. See [“Entering Invalid engine mode” on page 273](#).
- 2 Open a web browser, and then type the printer IP address.
Note: If the web page cannot be accessed or an error occurs when starting the printer into Invalid engine mode, then data backup is not an option. Inform the customer that the data cannot be saved.
- 3 Navigate to **Settings > Solutions > Embedded Solutions**.
- 4 From the Embedded Solutions page, select the applications that you want to import.
- 5 Click **Import**.

Ribbon cable connectors

Zero Insertion Force (ZIF) connectors

Zero Insertion Force (ZIF) connectors are used on the boards and cards used in this printer. Before inserting or removing a cable from these connectors, read this entire section. Great care must be taken to avoid damaging the connector or cable when inserting or removing the cable.

Warning—Potential Damage: Do not insert the cable so that the contacts are facing the locking actuator. The contacts always face away from the actuator.

Warning—Potential Damage: Do not insert the cable diagonally into the ZIF socket. This can cause damage to the contacts on the cable.

Warning—Potential Damage: Avoid using a fingernail, or sharp object to open the locking mechanism. This could damage the cable.

Warning—Potential Damage: Avoid pressing against the cable when opening the locking mechanism. This can also damage the cable.

These are the types of ZIF connectors used in this printer:

- Horizontal top contact connector
- Horizontal bottom contact connector
- Vertical mount contact connector
- Horizontal sliding connector

Horizontal top contact connector

This FRU contains a horizontal top contact cable connector. Read the instructions before proceeding.

The horizontal top contact connector uses a back flip locking actuator to lock the ribbon cable into the Zero Insertion Force (ZIF) connector. The cable is inserted horizontally into the connector.

Warning—Potential Damage: When opening or closing this type of actuator, gently lift or close the two tabs located on each end of the actuator. The two tabs should be moved simultaneously. Do not close the actuator from the center of the actuator.

Removing a cable from the horizontal top contact connector

- 1 Place a finger at each end of the locking actuator, and then gently lift the actuator to the unlocked position.

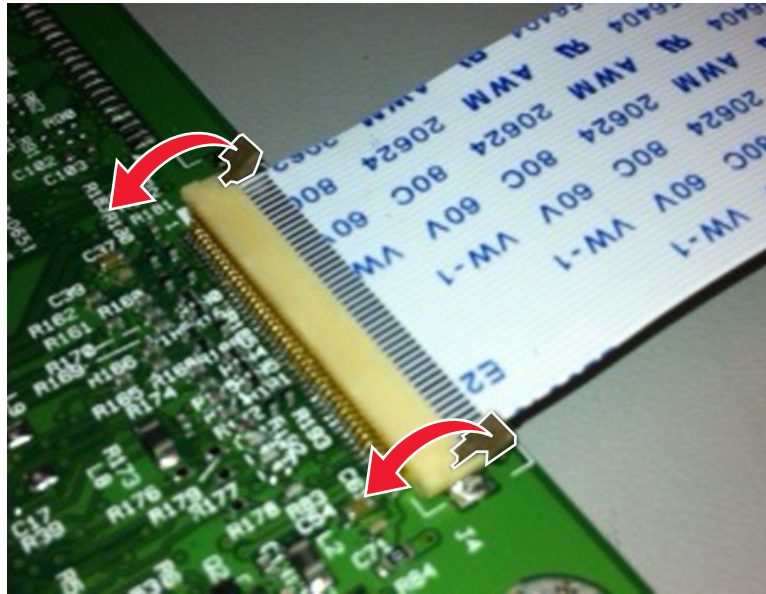

- 2 Slide the cable out of the connector.

- 3 Rotate the locking actuator to the locked position. The cable should not move while this step is performed. If the cable moves, open the actuator, reposition the cable, and then close the actuator to the down position.

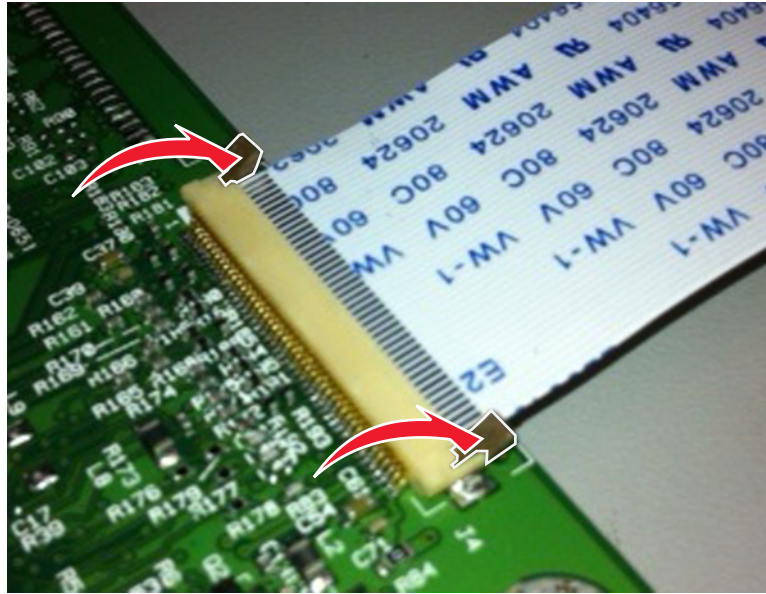

Horizontal bottom contact connector

This FRU contains a horizontal bottom contact cable connector. Read the instructions before proceeding.

The horizontal bottom contact connector uses a flip locking actuator to lock the ribbon cable into the Zero Insertion Force (ZIF) connector. The cable is inserted horizontally into the connector.

Warning—Potential Damage: When opening or closing this type of actuator, gently lift the center of the actuator using your finger. Do not use a fingernail or screwdriver to open the actuator. This could damage the ribbon cable. Do not close the actuator from the ends of the actuator.

Removing a cable from the horizontal bottom contact connector

- 1 Place two fingers towards each end of the locking actuator, and then gently lift the actuator to the unlocked position.

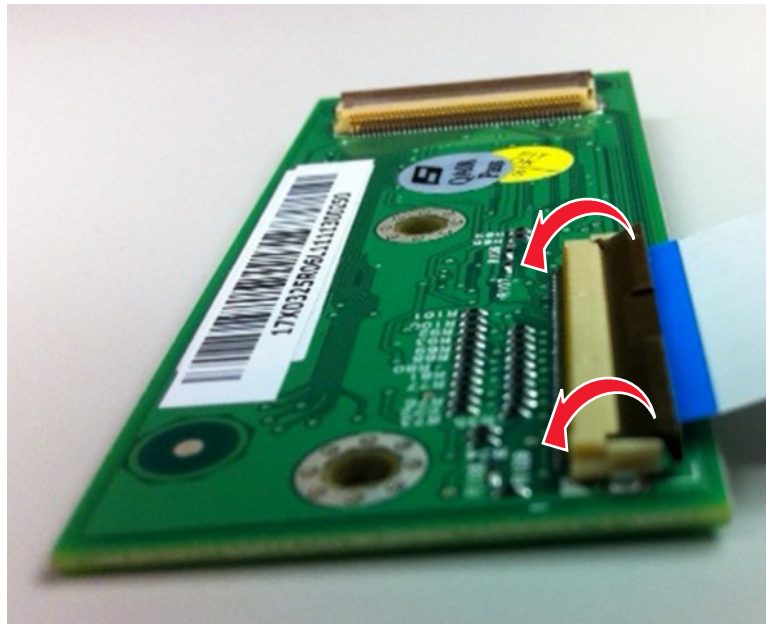

- 2 Slide the cable out of the connector.

Inserting a cable into the horizontal bottom contact connector

- 1 Check the actuator to verify it is in the open position.



- 2 Insert the cable into the ZIF connector with the contacts facing downward and away from the locking actuator. The cable needs to be inserted below the actuator.

Note: Verify that the cable is installed squarely into the connector. If the cable is not squarely installed, then intermittent failures could occur.



- 3 Place your finger in the middle of the actuator, and then rotate the locking actuator to the locked position.

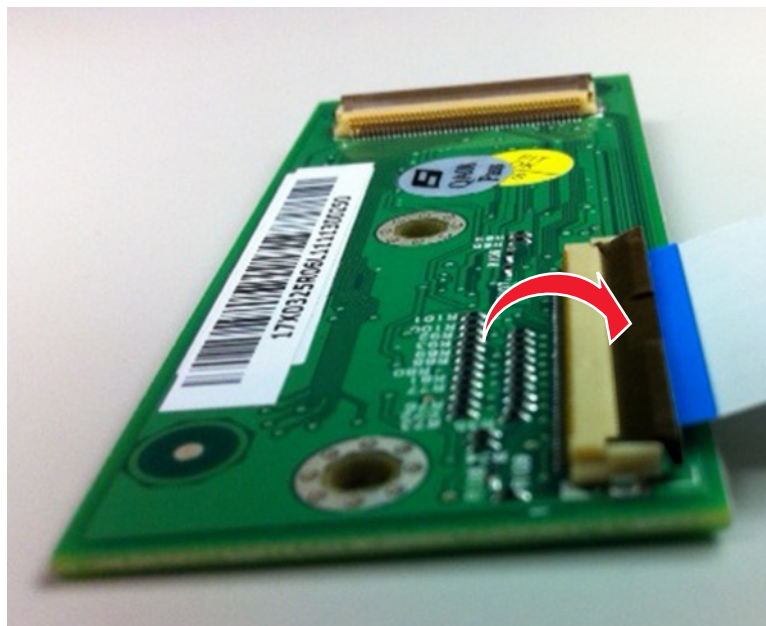

Vertical mount contact connector

This FRU contains a vertical mount contact connector. Read the instructions before proceeding.

The vertical mount contact connector uses a back flip locking actuator to lock the ribbon cable into the Zero Insertion Force (ZIF) connector. The cable is inserted vertically into the connector.

Warning—Potential Damage: When opening or closing this type of actuator, gently lift the center of the actuator using your finger. Do not use a fingernail or screwdriver to open the actuator. This could damage the ribbon cable. Do not close the actuator from the ends of the actuator.

Removing a cable from the vertical mount contact connector

- 1 Gently rotate the locking actuator from the center of the actuator to the unlocked position.

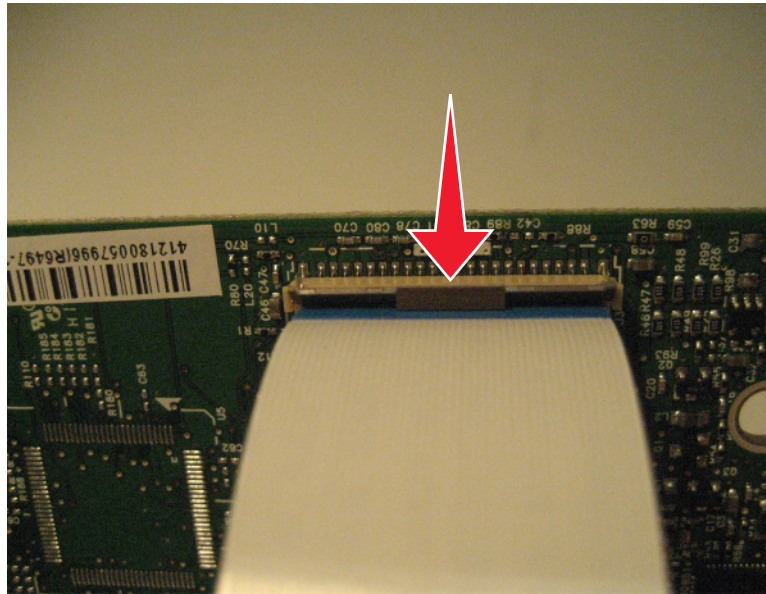

- 2 Slide the cable out of the connector.

Inserting a cable into the vertical mount contact connector

- 1 When installing the cable, check the locking actuator to verify it is in the open position.



- 2 Insert the cable with the contacts on the cable away from the locking actuator. Insert the cable on top of the actuator.

Note: Verify that the cable is installed squarely into the connector. If the cable is not squarely installed, then intermittent failures could occur.



- 3 Rotate the locking actuator to the locked position by pressing down on both ends of the actuator. The cable should not move when this step is performed. If the cable moves, open the actuator, reposition the cable, and then close the actuator to the down position.

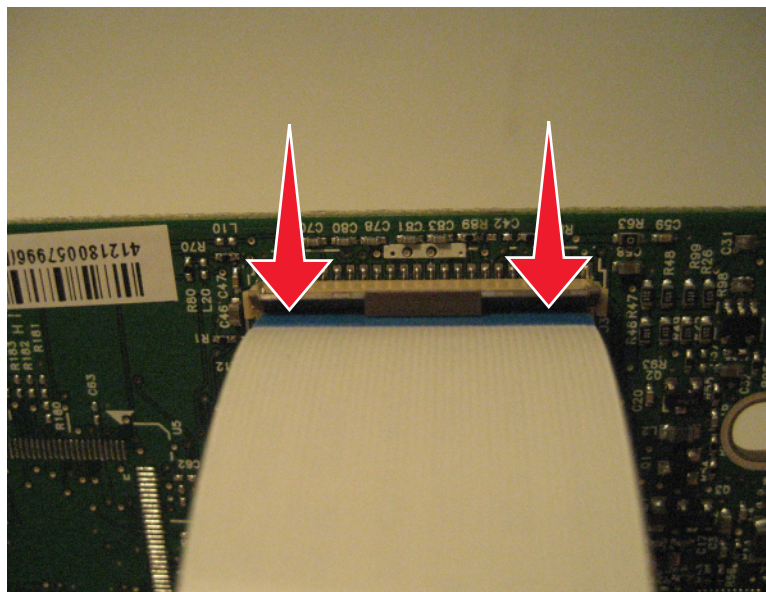

Horizontal sliding contact connector

This FRU contains a horizontal sliding contact connector. Read the instructions before proceeding.

The horizontal sliding contact connector uses a slide locking actuator to lock the ribbon cable into the Zero Insertion Force (ZIF) connector. The cable is inserted horizontally into the connector.

Warning—Potential Damage: When opening or closing this type of actuator, gently push or pull the two tabs located on each end of the actuator. Do not close the actuator from the center of the actuator. Do not use a screwdriver to open or close the actuator. Damage to the cable or connector could occur.

Removing a cable from the horizontal sliding contact connector

- 1 Simultaneously slide the two tabs located on the ends of the locking actuator away from the connector.

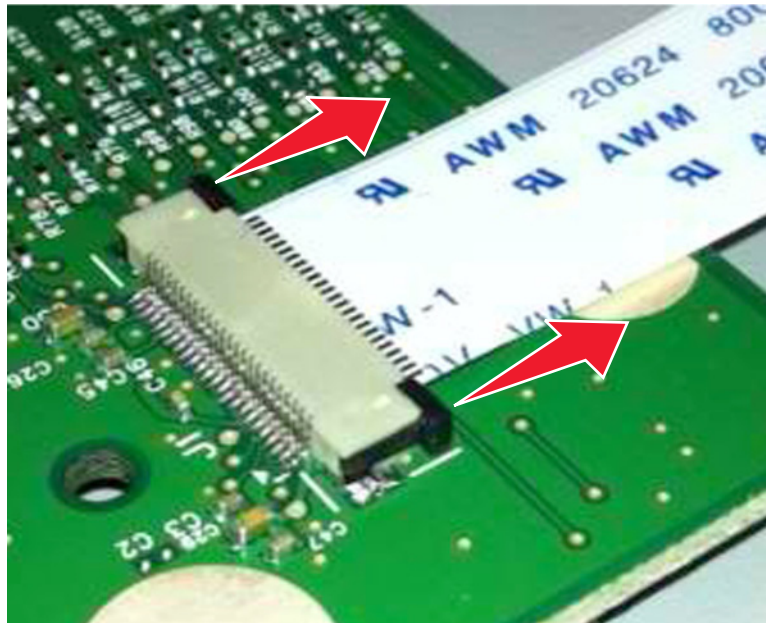

- 2 Slide the cable out of the connector.

Inserting a cable into the horizontal sliding contact connector

- 1 When installing the cable, check the locking actuator to verify it is in the open position. If you are opening the connector, pull back on both end tabs using equal force to avoid breaking the connector.

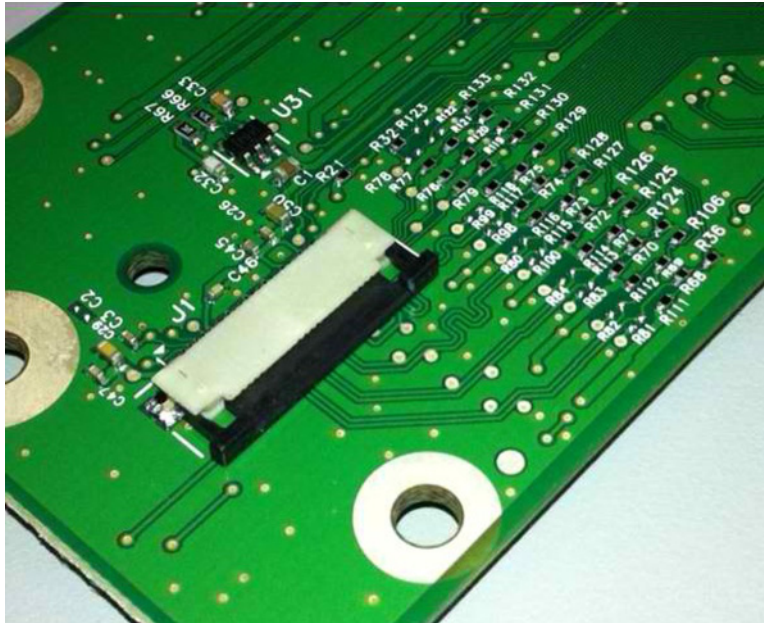

- 2 Insert the cable with the contacts on the cable facing away from the locking actuator. Insert the cable on top of the actuator.



- 3 Slide the locking actuator towards the connector, locking the cable into place. The cable should not move when this step is performed. If the cable moves, open the actuator, reposition the cable, and then close the actuator to the down position.

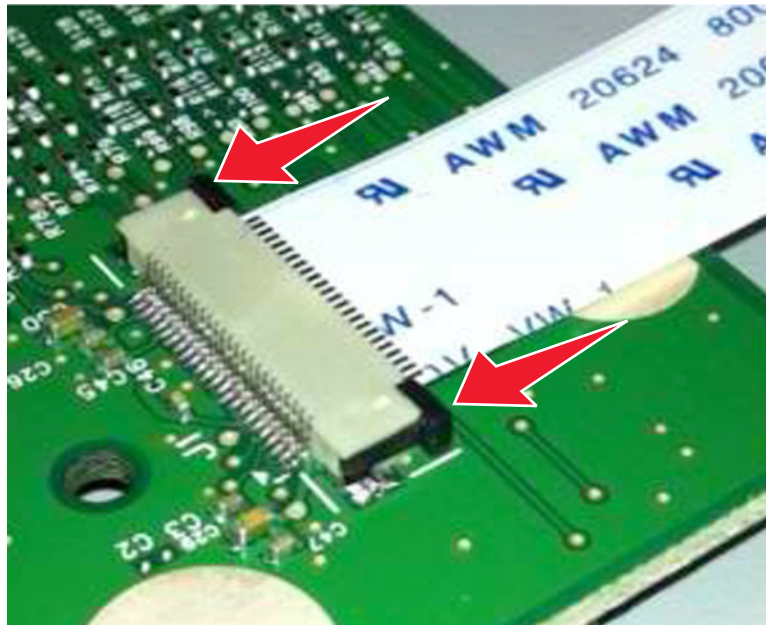

Low Insertion Force (LIF) connector

This FRU contains a Low Insertion Force (LIF) connector. Read the instructions before proceeding.

Warning—Potential Damage: When installing a cable into an LIF connector, care must be taken to avoid bending the edges of the cables and damaging the contacts on the cables.

Inserting a cable into the LIF connector

- 1 Looking at the connector, take note on which side the contacts are located. Many boards will have the word “contacts” stamped on them to indicate which side of the LIF has the contacts. When looking at the board, take note that the contacts from the board to the connector are located on the side of the connector with the contacts.

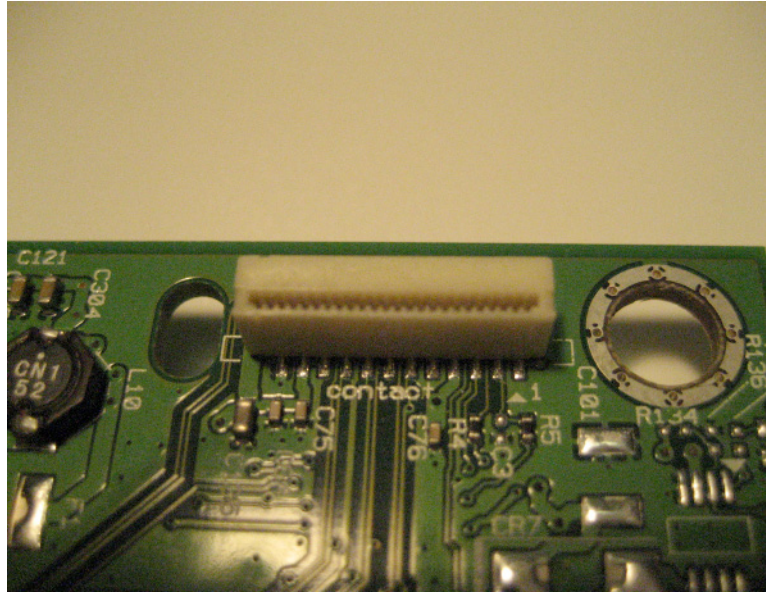

- 2 Insert the cable squarely into the connector.

Note: Verify that the cable is installed straight into the connector. If the cable is not installed properly, then intermittent failures could occur.

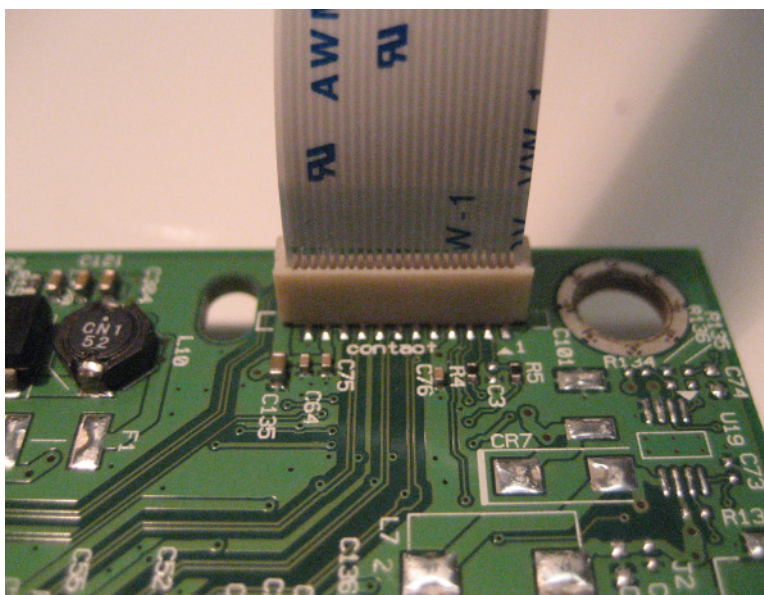

Printhead assembly adjustments

Printhead assembly mechanical adjustment

A printhead needs to be correctly positioned after it has been removed. Use a sharp pencil or a small, flat-blade screwdriver to mark the location of the old printhead on the printer frame. Align the new printhead relative to the location of the old printhead.

Note: Skew is caused by a sheet being fed through the printer while misaligned. The entire image is rotated relative to the sheet edges. However, a mechanically misaligned printhead causes the horizontal lines to appear skewed, while the vertical lines remain parallel to the vertical edges. There are no adjustments for skew. Check the pick tires for wear, the paper path for obstructions, the fuser for proper setting, and the tray paper guides for fit to the media.

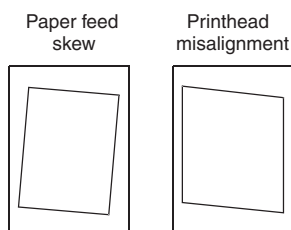

To adjust the printhead:

- 1 POR into the Diagnostics menu, and print a Quick test page:
Diagnostics Menu > Print Tests > Tray 1 > Single
- 2 Fold the printed test page on the left side so that a few millimeters of grid lines wrap around the outside of the fold.

- 3 Fold a second vertical fold near the center so that the left side top edge aligns with the right side top edge.

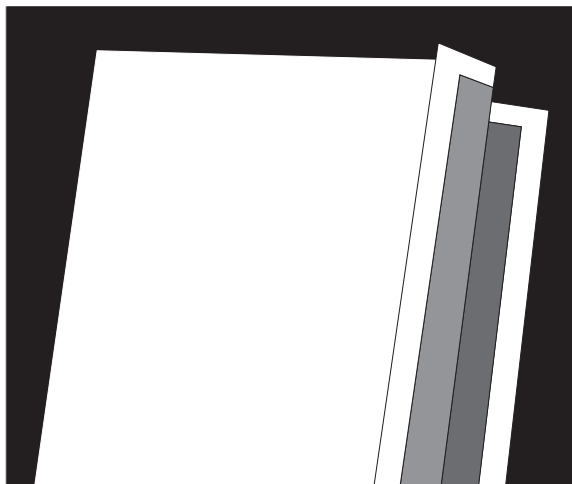

- 4 If the grid lines of the right flap align below the corresponding lines on the left flap, then adjust the printhead clockwise relative to the printer, and recheck. If the grid lines of the left flap align below the corresponding lines of the right side, then adjust the printhead counterclockwise.

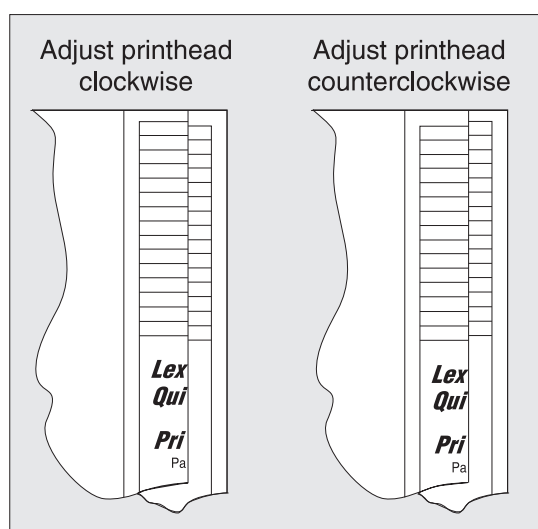

- 5 Print another Quick test page, and check if adjustments are still needed.
- 6 After obtaining a properly adjusted image on the paper, tighten all the screws.
- 7 Align the printhead electronically.

Printhead assembly electronic adjustment

Note: Before aligning the printhead electronically, first align the printhead mechanically.

- 1 POR into the Diagnostics menu, and print a Quick test page:

Diagnostics Menu > Registration > Quick Test

Sample Quick test page. Use the actual sheet.

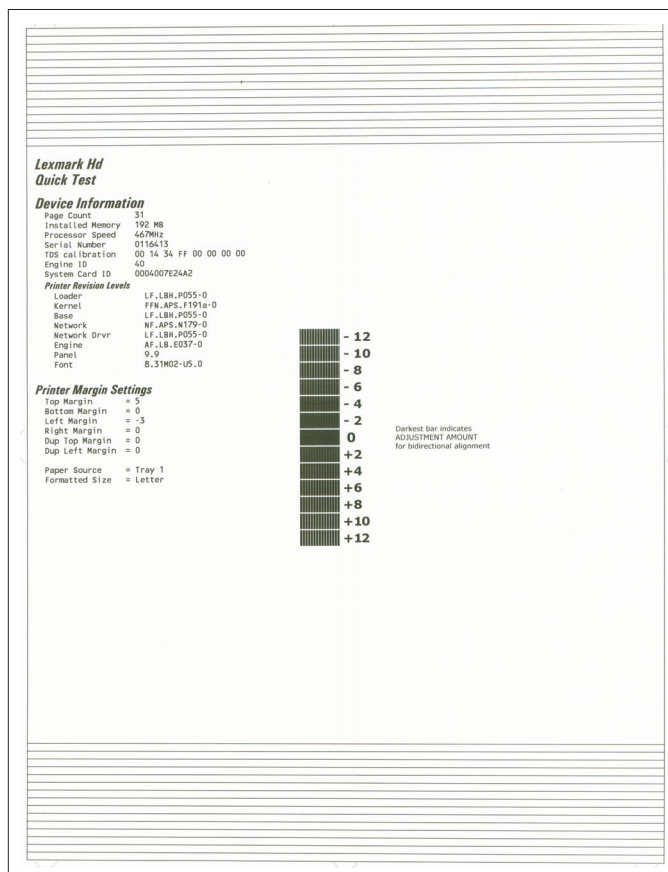

- 2 From the Registration menu, select the Right margin setting:
Diagnostics Menu > Registration > Right Margin
- 3 To determine the Right margin setting:
 - a Choose the value of the darkest bar on the right side of the Quick test page.
 - b Add that value to the current Right margin setting found on the left side of the Quick test page.
 For example, if the current Right margin setting is -2, and the darkest bar is at +3, then the right margin setting will be equal to +1 (-2+3=+1).
- 4 Choose and save the desired Right margin setting.
- 5 Print again a Quick test page and check if the darkest bar is at zero. If it is, then check to see if the left, top, and bottom margins are detected. If the darkest bar is not at zero, then repeat steps 3 and 4.

Note: The alignment of the left margin positions the black plane to the right or left. The alignment of the right margin does not alter the margins and should only be used to adjust the printhead.

Removal procedures

Keep the following tips in mind as you replace parts:

- Some removal procedures require removing cable ties. You must replace cable ties during reassembly to avoid pinching wires, obstructing the paper path, or restricting mechanical movement.
- Remove the toner cartridges, imaging unit, and media tray before removing other printer parts. The imaging unit should be carefully set on a clean, smooth, and flat surface. It should also be protected from light while out of the device.
- Disconnect all external cables from the printer to prevent possible damage during service.
- Unless otherwise stated, reinstall the parts in reverse order of removal.
- When reinstalling a part held with several screws, start all screws before the final tightening.

Left side removals

Left cover removal

- 1 Remove the paper tray.
- 2 Remove the screw (A) securing the left cover to the front of the printer frame.

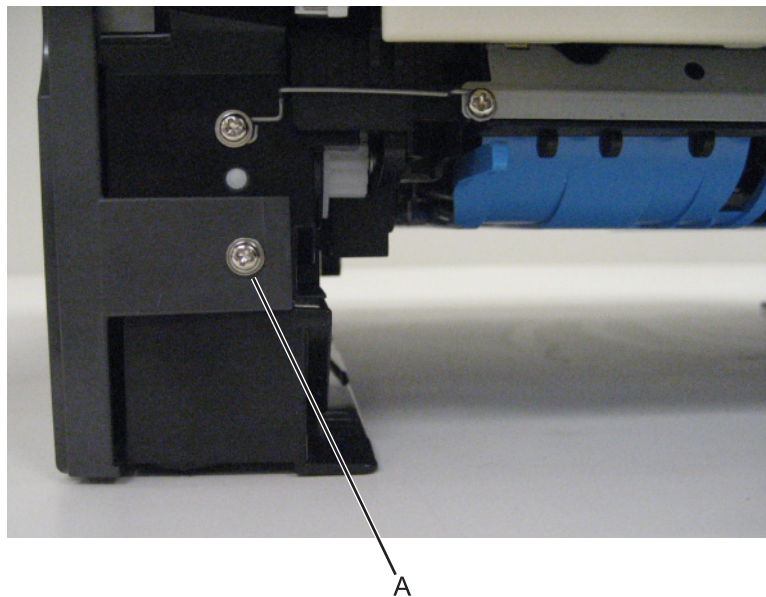

- 3** Release the two tabs (B) on the bottom of the cover.

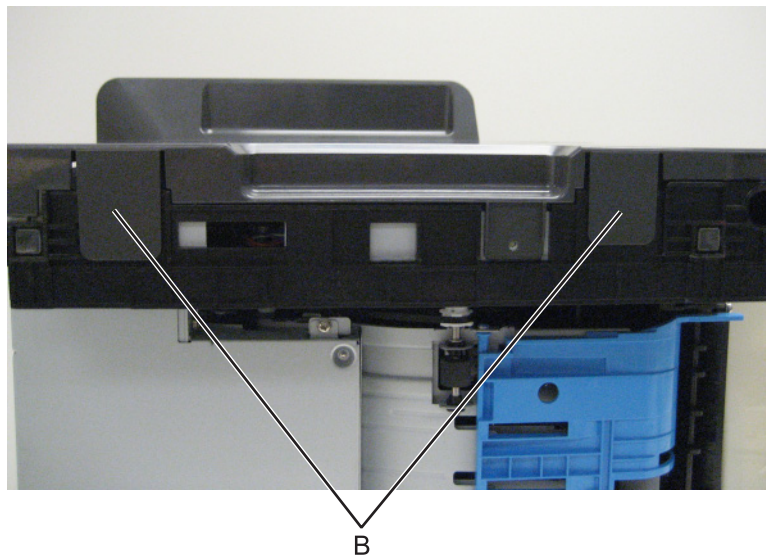

- 4** Pull the cover forward, and remove it from the printer.

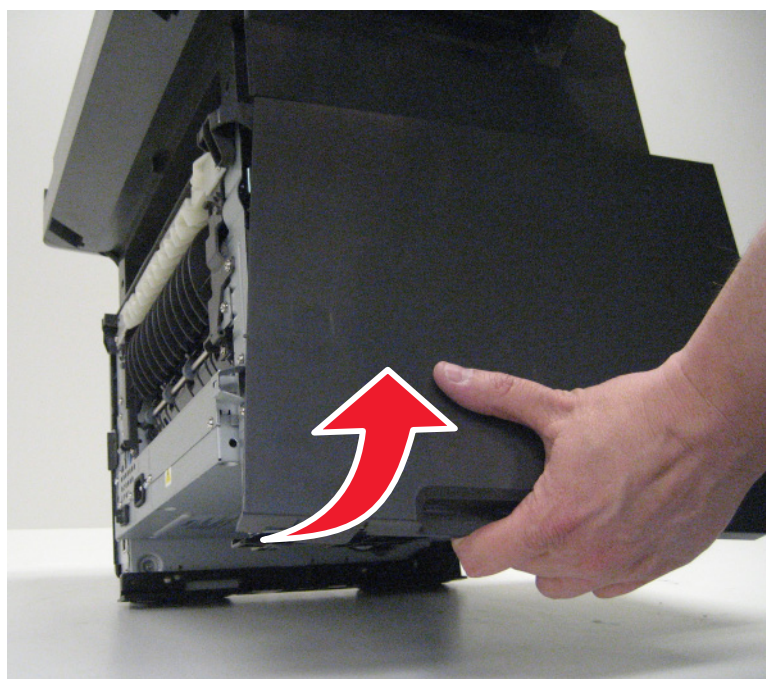

Main drive gearbox removal

- 1 Remove the left cover. See [“Left cover removal” on page 302.](#)
- 2 Squeeze the latch, and then detach the link from the front door.

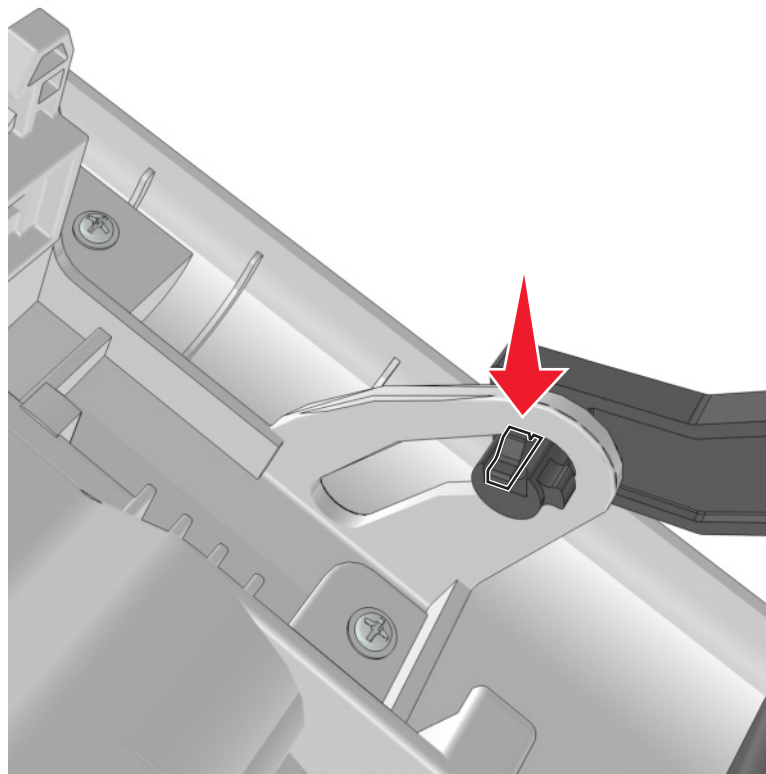

3 Remove the 4 screws (A), and then remove the main drive gearbox.

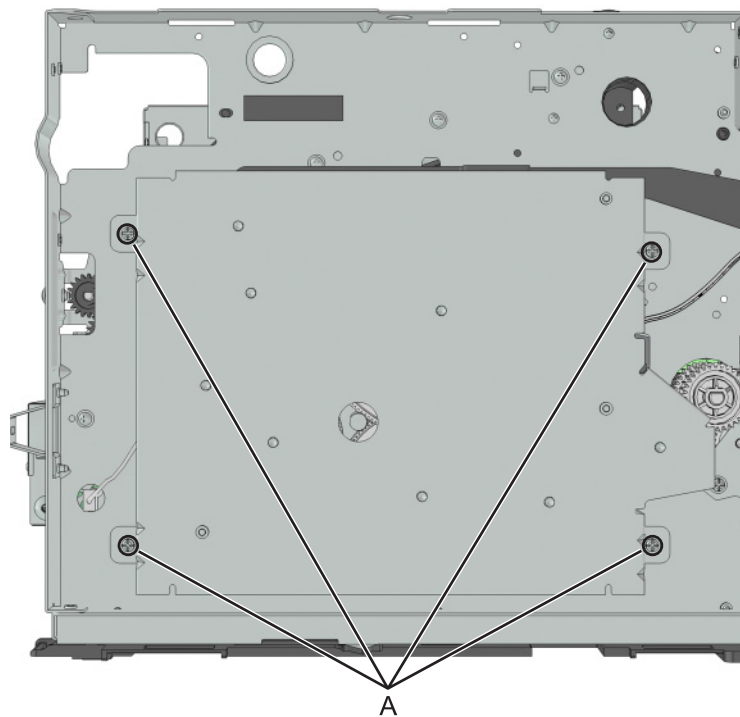

4 Disconnect the cable from the main drive gearbox.

- 5 Remove the spring (B) and the fuser gear (C).

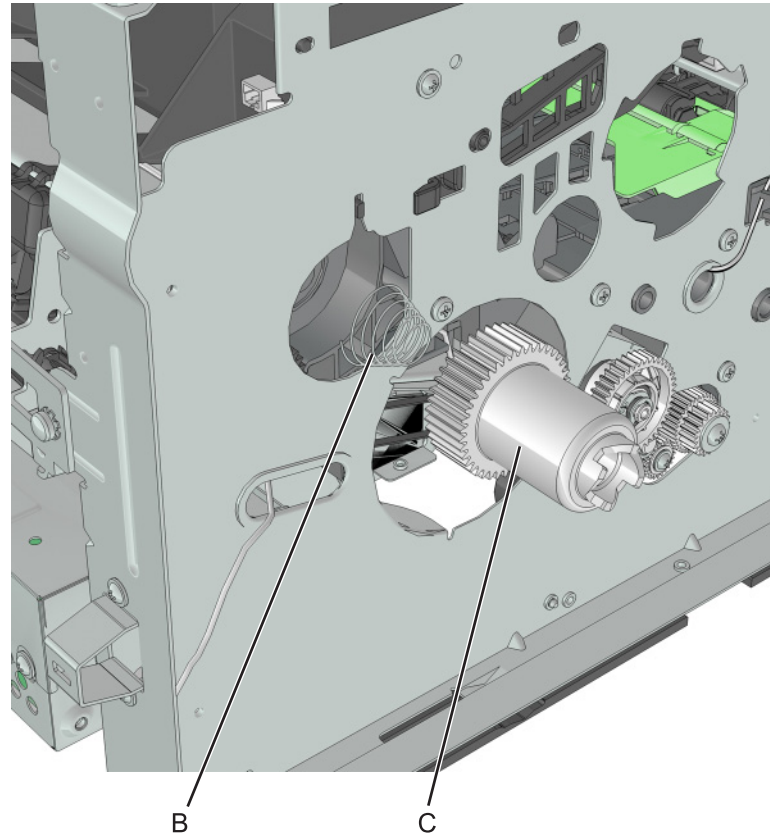

MPF solenoid removal

- 1 Remove the left cover. See [“Left cover removal” on page 302.](#)
- 2 Remove the main drive gearbox. See [“Main drive gearbox removal” on page 304.](#)
- 3 Disconnect the MPF solenoid cable from the controller board.
- 4 Remove the screw (A).

5 Cut the cable (B).

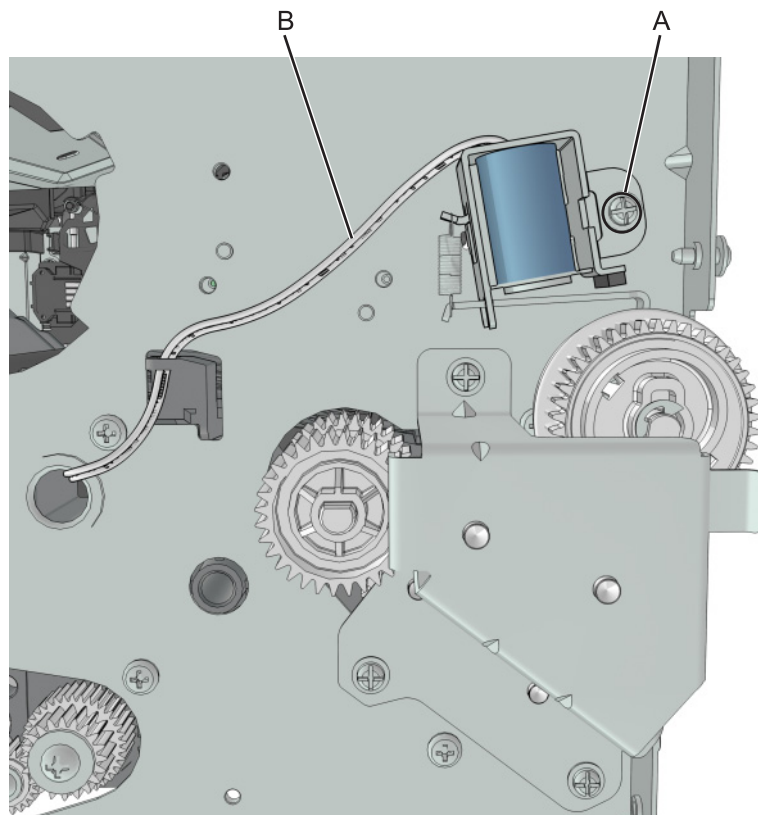

6 Remove the other half of the cable from the printer.

Installation notes:

- a** Install the MPF solenoid.
- b** Secure the cable to the holder (A).

- c Insert the cable into the hole (B).

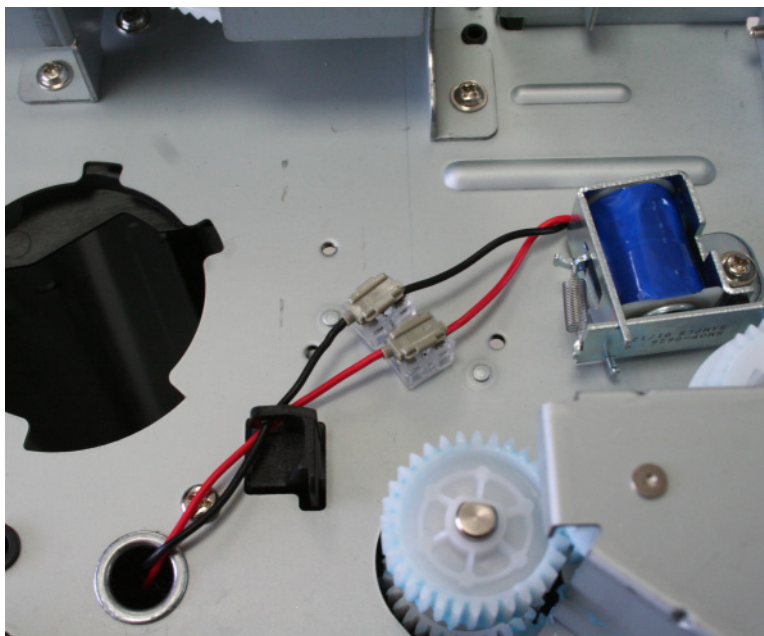

- d Route the cable using the new path, and secure it with a cable tie (C).

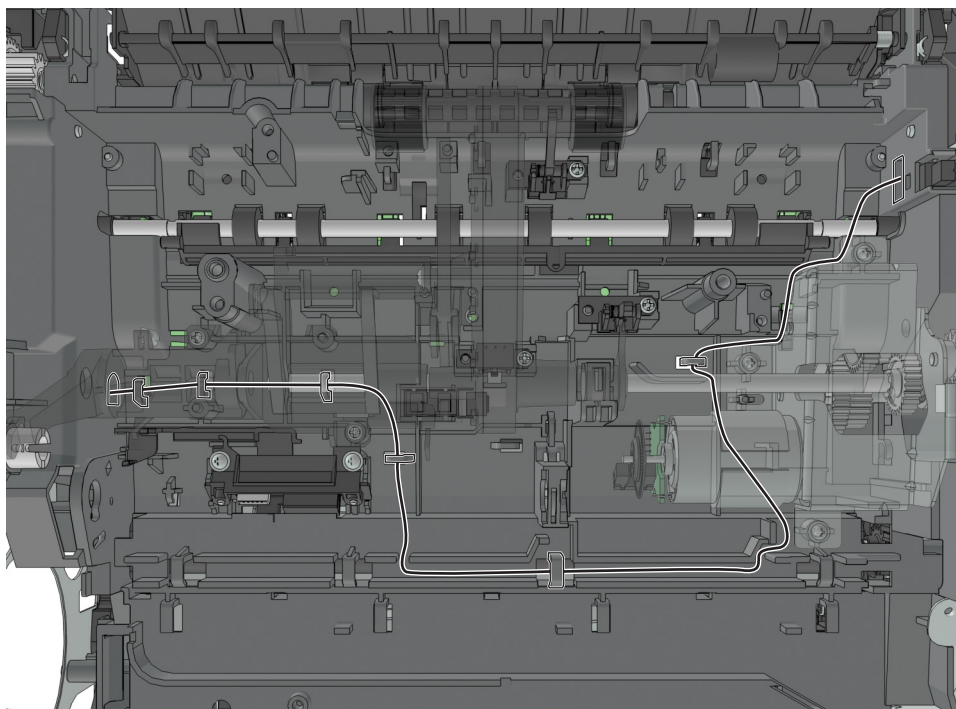

MPF gearbox removal

- 1 Remove the left cover. See [“Left cover removal” on page 302.](#)
- 2 Remove the main drive gearbox. See [“Main drive gearbox removal” on page 304.](#)
- 3 Remove the front access cover. See [“Front access cover removal” on page 354.](#)

- 4 Disconnect the spring from the printer (A).

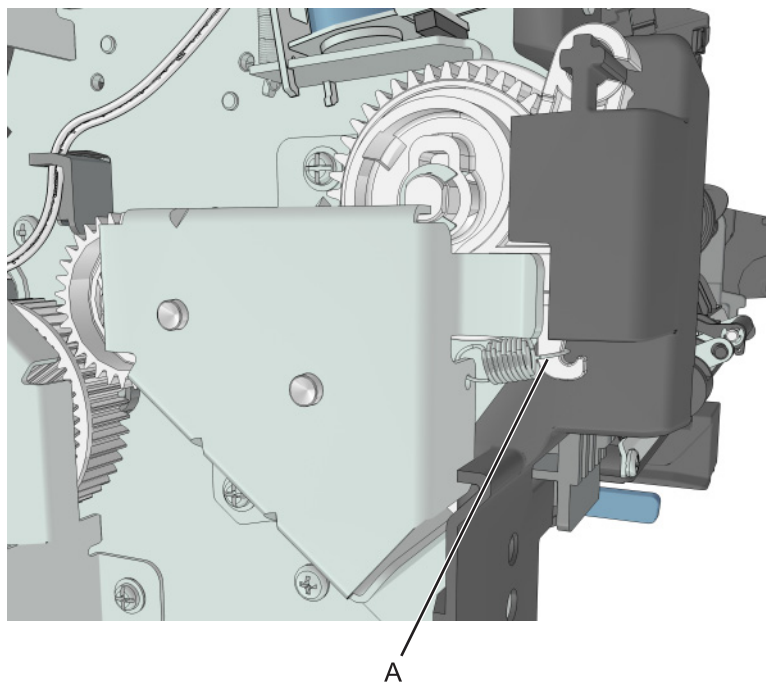

- 5 Remove the three screws (B), and then remove the front left mount.

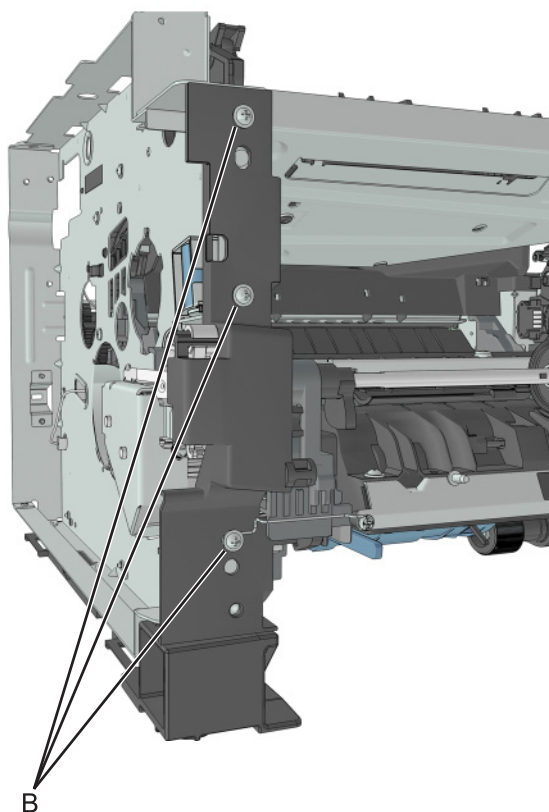

- 6 Remove the three screws (C), and then remove the MPF gearbox.

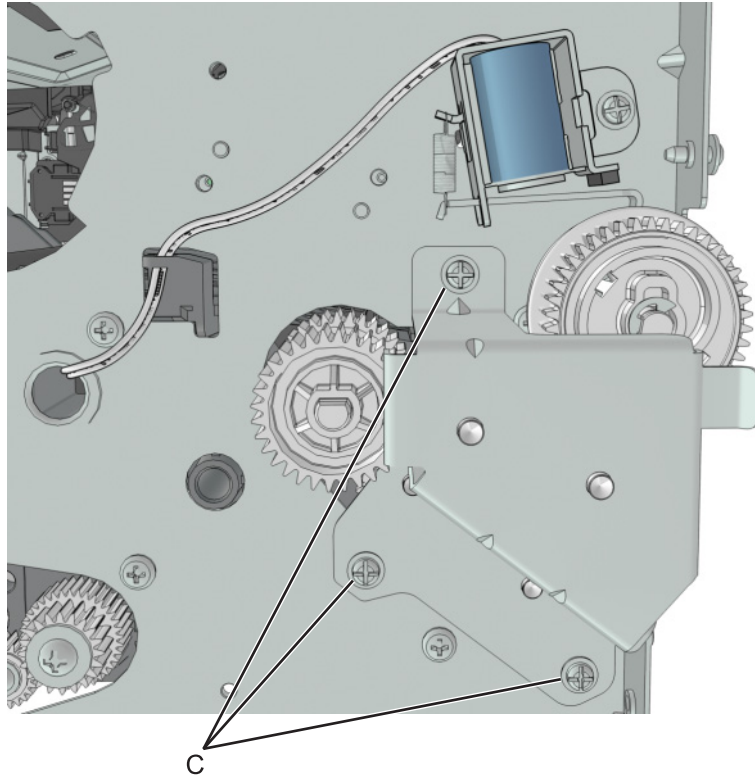

- 7 Release the two latches (D), and then remove the main input drive gears.

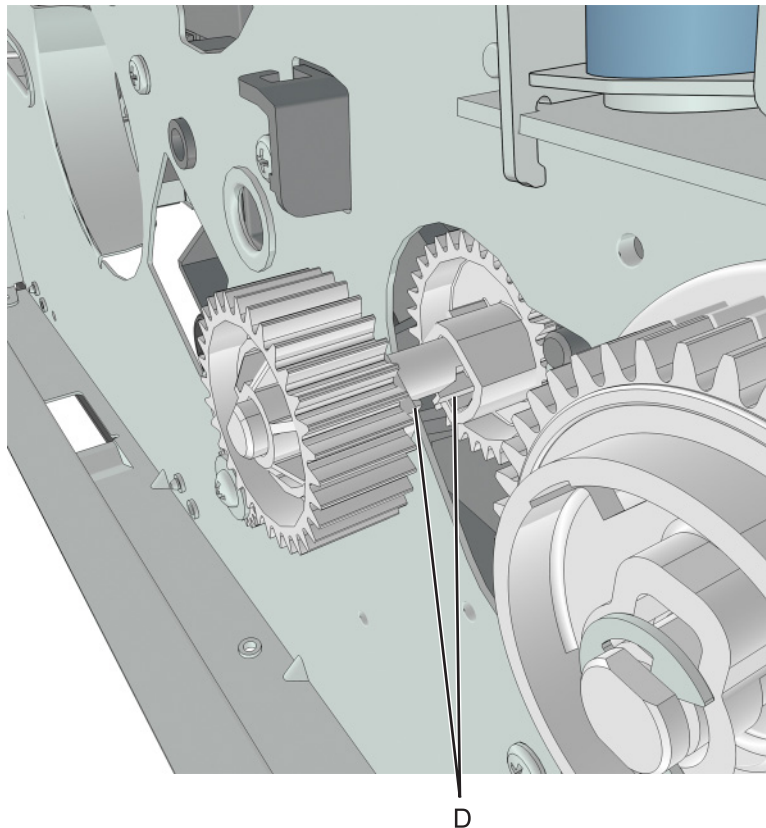

- 8 Remove the E-clip (E), and then remove the MPF sector gear (F).

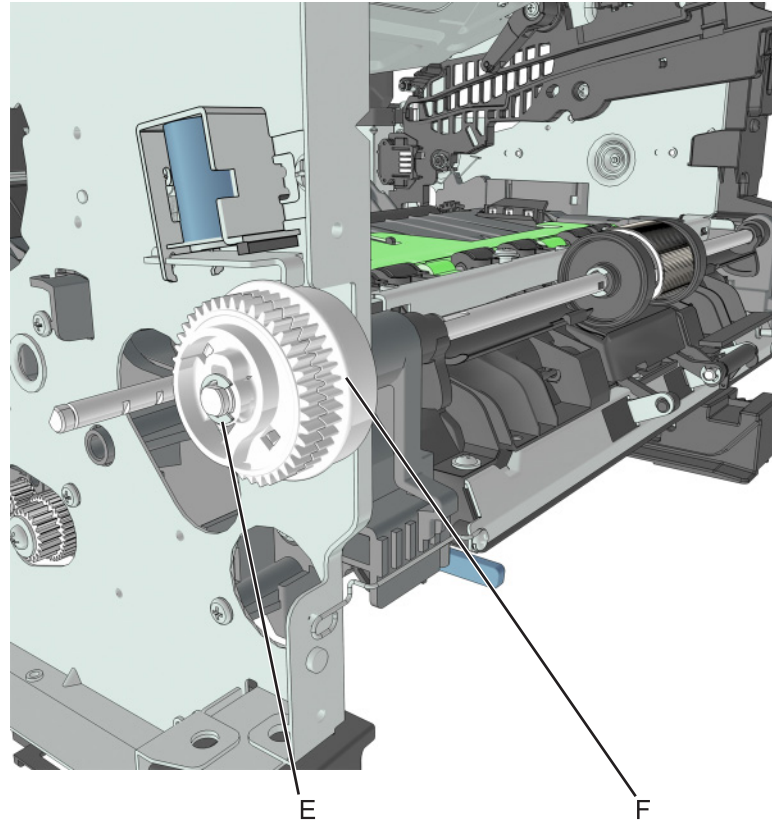

Reverse solenoid removal

- 1 Remove the right cover. See [“Right cover removal” on page 315.](#)
- 2 Remove the left cover. See [“Left cover removal” on page 302.](#)
- 3 Remove the rear door and cover. See [“Rear exit door removal” on page 381](#) and [“Rear cover removal” on page 382.](#)
- 4 Remove the scanner assembly. See [“Scanner assembly removal” on page 405.](#)
- 5 Remove the top cover. See [“Top cover removal” on page 391.](#)
- 6 Remove the cooling fan. See [“Cooling fan removal” on page 319.](#)
- 7 Disconnect cable J10 from the controller board.

- 8** Remove the two screws (A) securing the reverse solenoid.

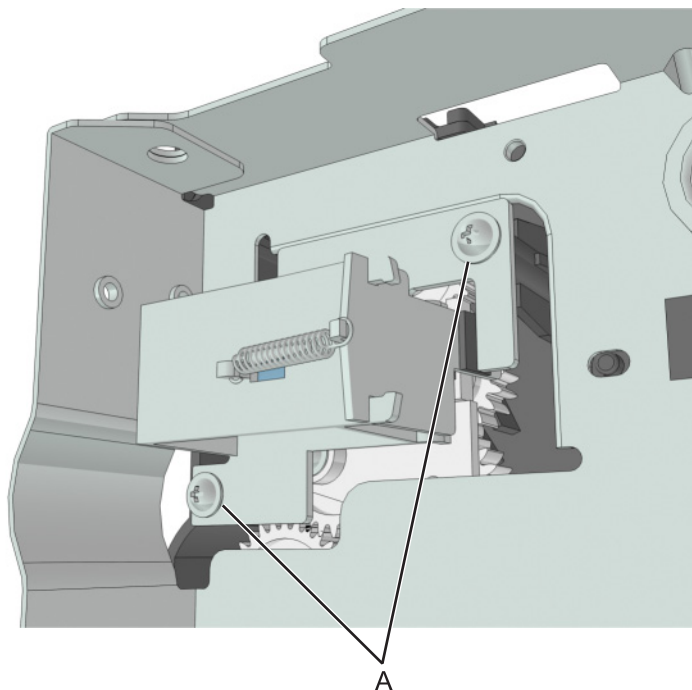

Cartridge gearbox removal

- 1** Remove the left cover. See [“Left cover removal” on page 302](#).
- 2** Remove the four screws (A) securing the cartridge gearbox.

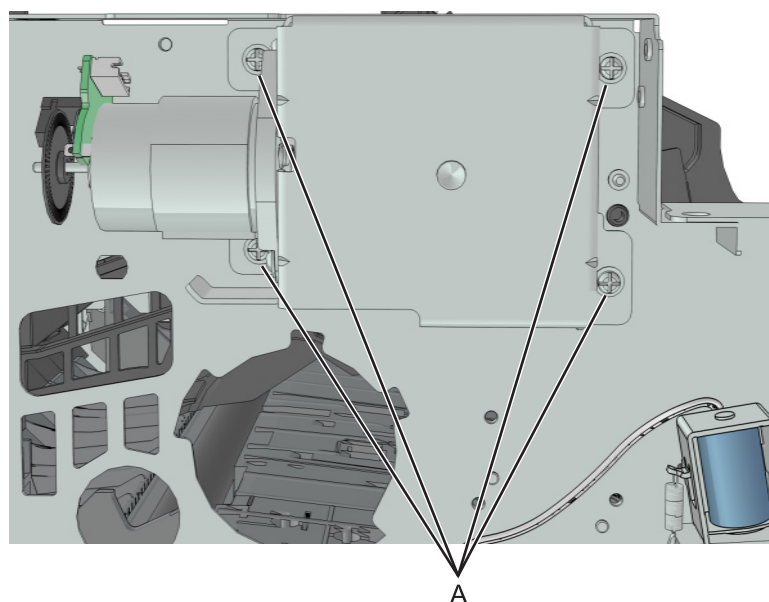

- 3** Disconnect the cable from the cartridge gearbox.

Duplex gear assembly removal

- 1 Remove the left cover. See [“Left cover removal” on page 302.](#)
- 2 Remove the rear door and cover. See [“Rear exit door removal” on page 381](#) and [“Rear cover removal” on page 382.](#)
- 3 Remove the power supply. See [“Power supply removal” on page 361.](#)
- 4 Remove the power supply shield. See [“Power supply shield removal” on page 361.](#)
- 5 Remove the duplex. See [“Duplex removal” on page 362.](#)
- 6 Position the printer so that it sits on its right side.
- 7 Remove the E-clip (A).
- 8 Remove the screw (B).
- 9 Remove the screw (C).
- 10 Remove the three gears.

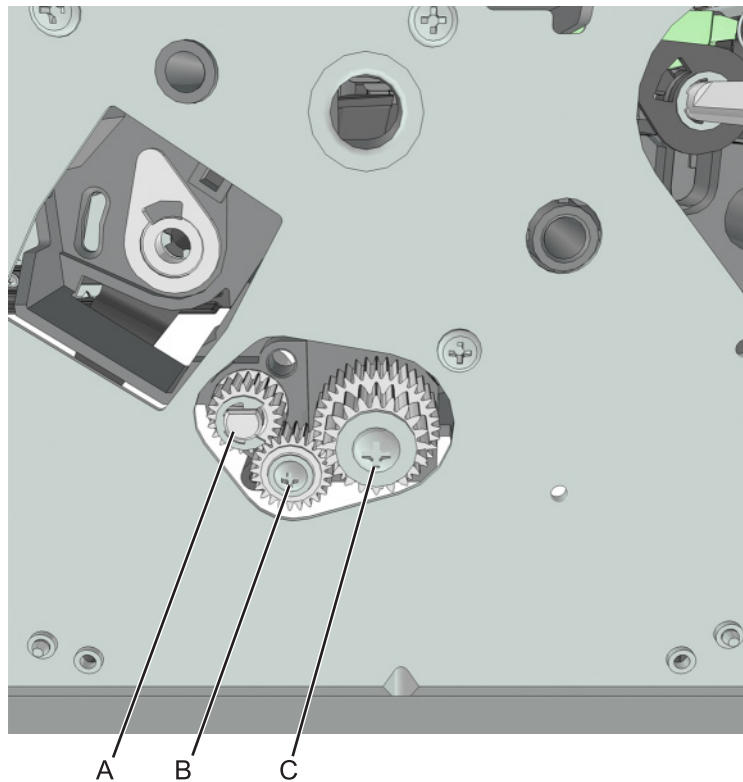

- 11** From behind the three gears, remove the duplex coupling (D).

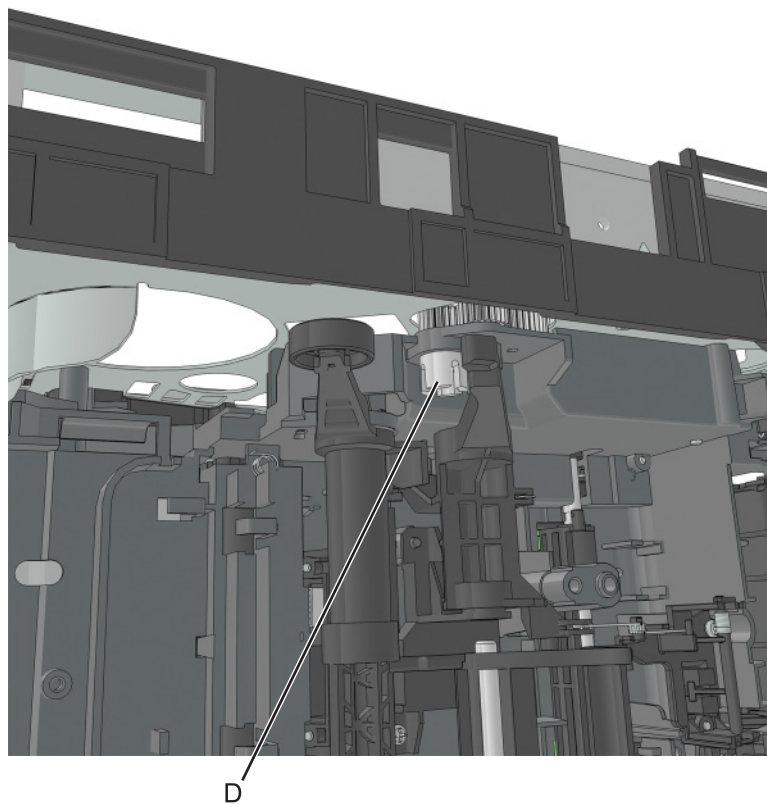

- 12** Remove the duplex link (E) from the duplex.

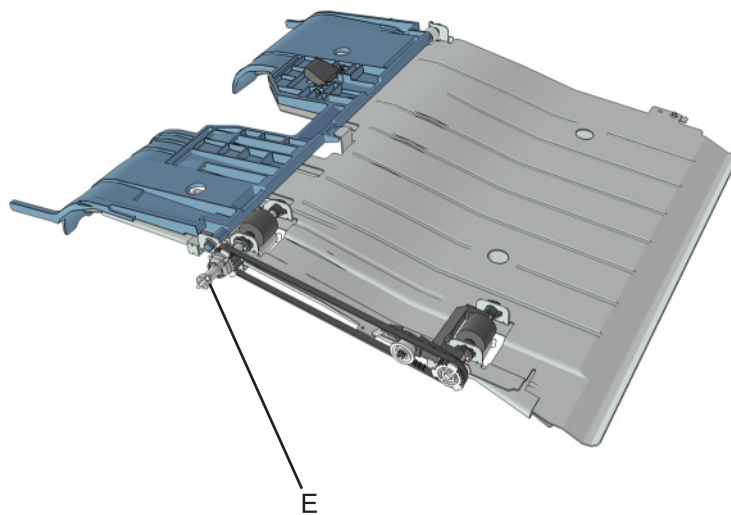

Right side removals

Right cover removal

- 1 Remove the paper tray and toner cartridge.
- 2 Position the printer so that it sits on its left side.
- 3 Remove the two screws (A), and then release the latches (B) to remove the right cover.

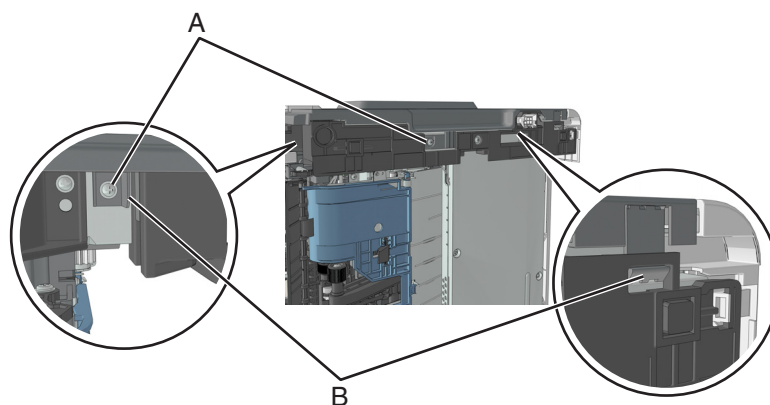

- 4 Open the memory access cover.

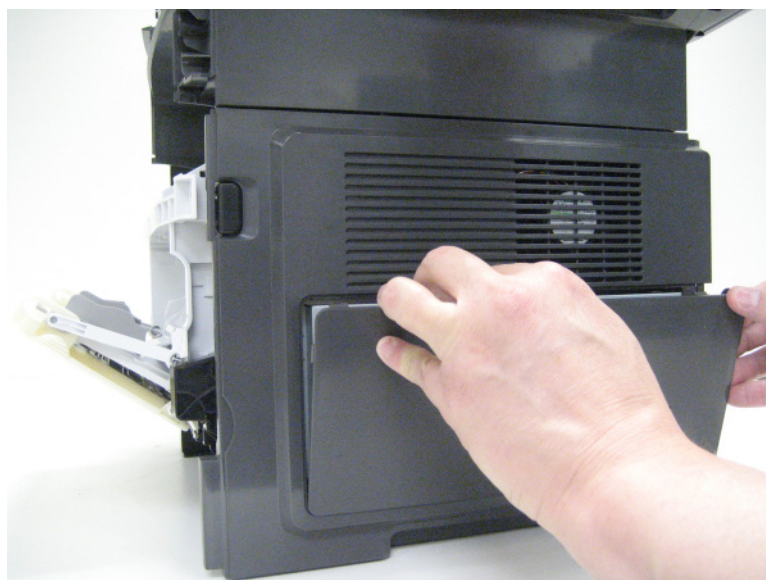

- 5 Remove the two screws (C) securing the right cover to the RIP shield.

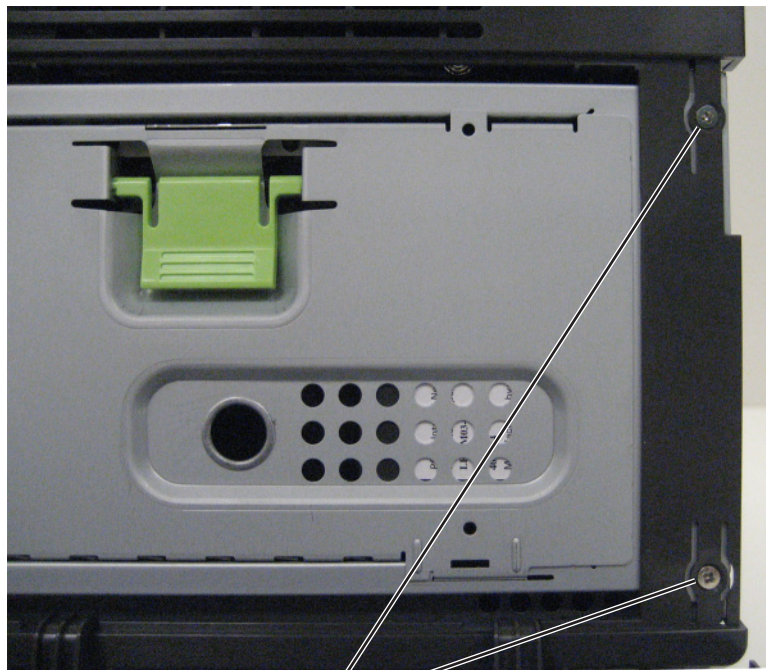

- 6 Open the front cover.

- 7 Slightly lift the printer, slide the right cover forward, and pull it out and away from the printer.



Memory access door removal

- 1 Open the memory access door.
- 2 Gently release the latches (A) securing the access door to the right cover.

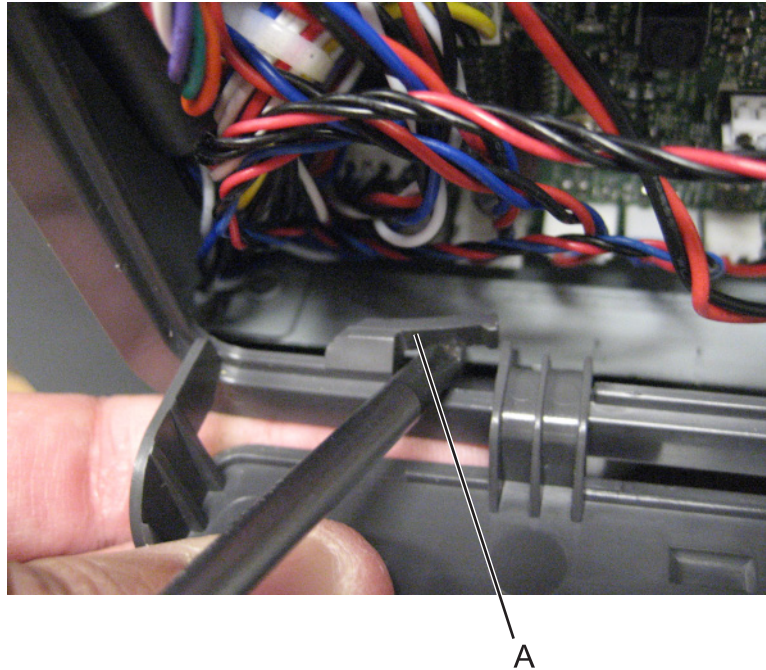

- 3 Slide the access door to release the hinges, then remove it from the right cover.

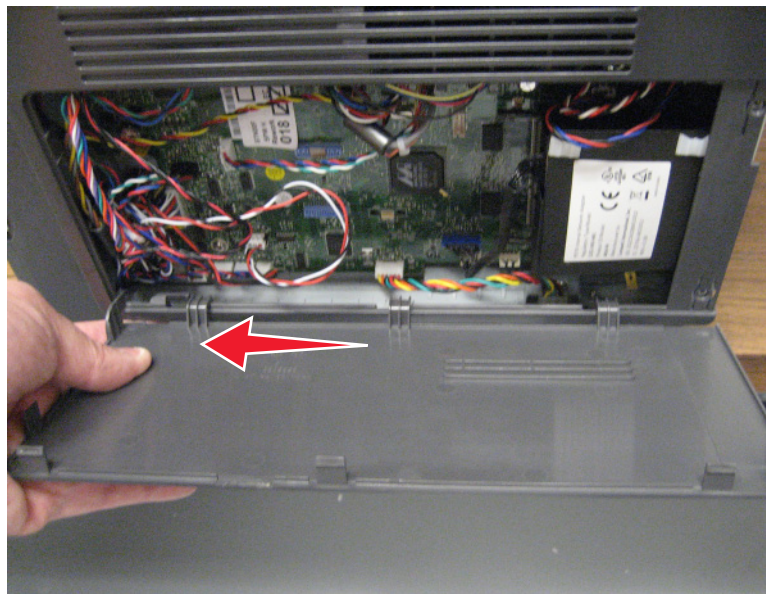

Tray present sensor removal

- 1 Remove the right cover. See [“Right cover removal” on page 315.](#)
- 2 Disconnect the cable (A) from the tray present sensor.

3 Pry to remove the sensor retainer (B).

Note: The retainer is secured to the sensor by an adhesive.

4 Release the three latches (C), and then pry to remove the tray present sensor.

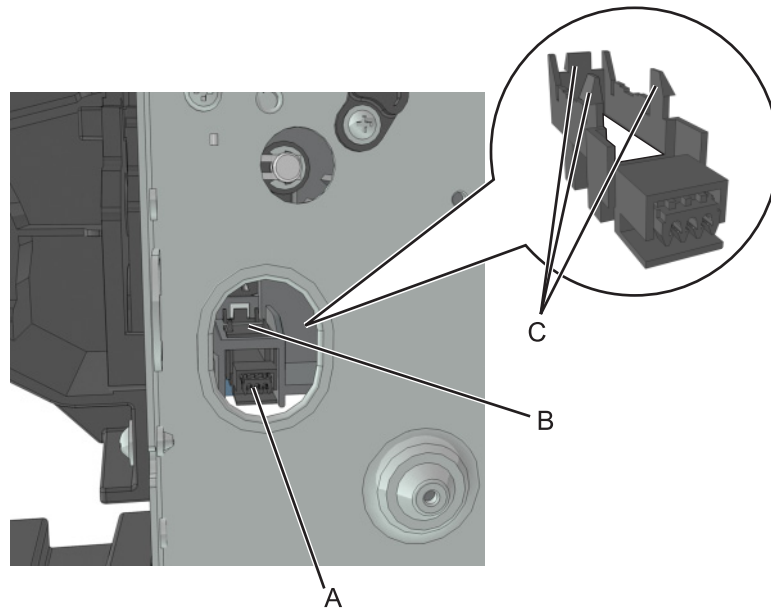

Cooling fan removal

1 Remove the right cover. See [“Right cover removal” on page 315](#).

2 Disconnect the cable JFAN1 from the controller board.

- 3 Remove the two screws (A), and then remove the fan.

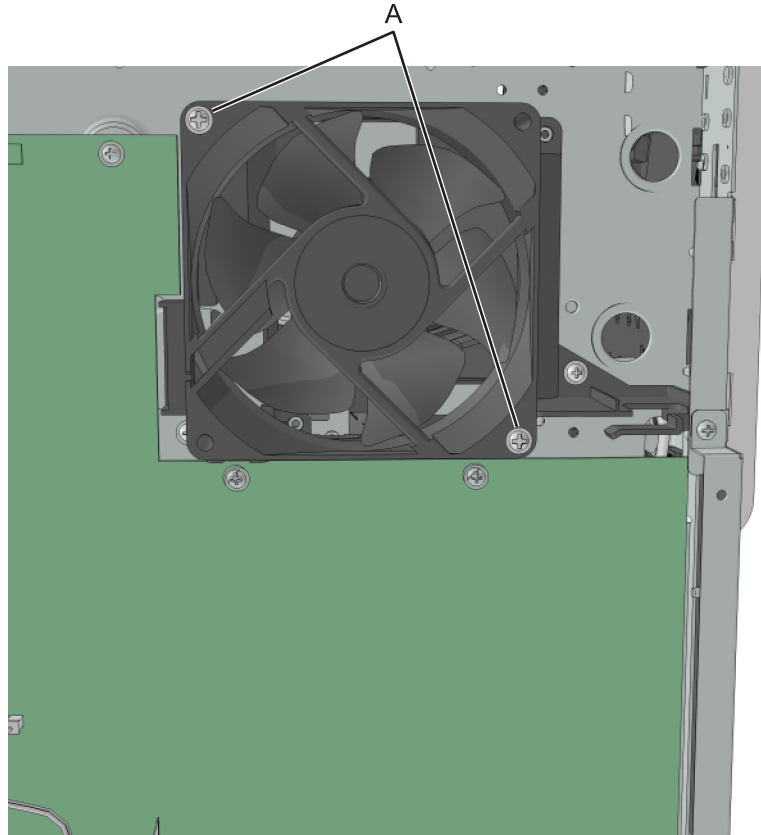

Controller board removal

Note: Back up the eSF solutions and settings before replacing the controller board. For more information, see [“Backing up eSF solutions and settings” on page 284](#).

- 1 Remove the right cover. See [“Right cover removal” on page 315](#).
- 2 Remove the controller board shield. See [“Controller board shield removal” on page 322](#).
- 3 Disconnect all internal options attached to the board (memory card, internal solutions port, hard disk).
- 4 Disconnect all cables from the controller board.

- 5** Remove the screw (A) from the rear side of the printer.

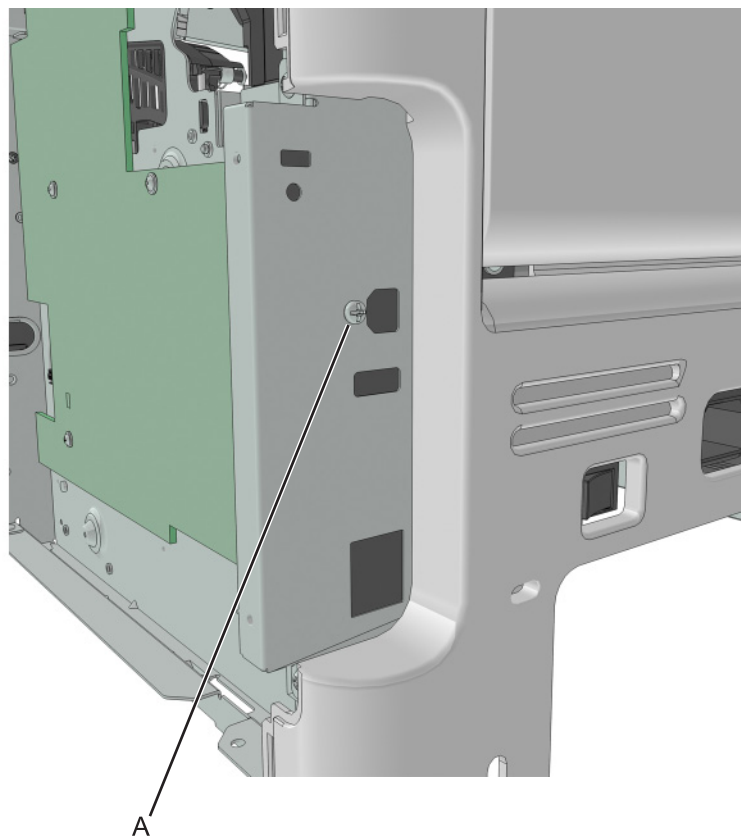

- 6** Remove the seven screws (B), then remove the controller board.

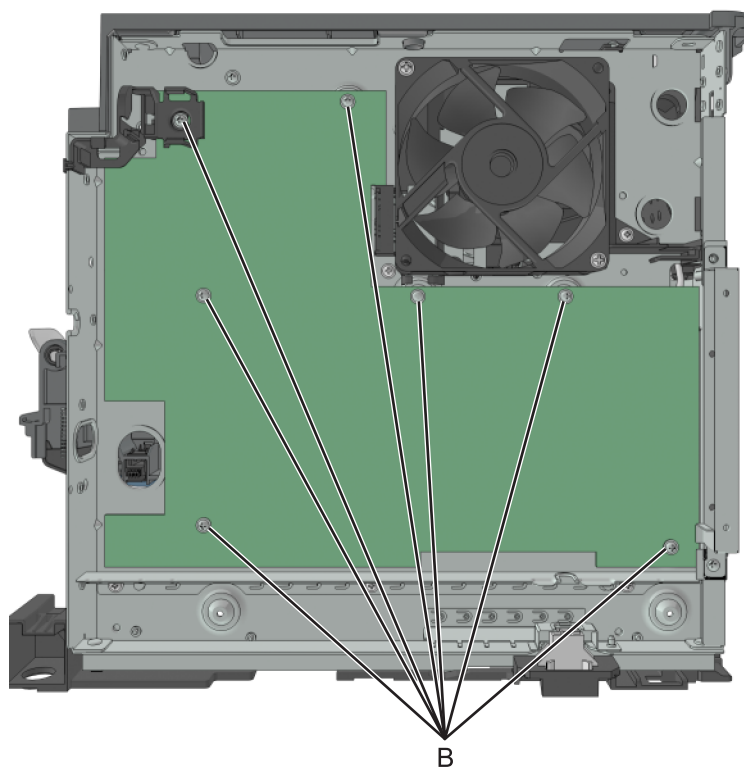

Parts removal

Installation note: After the new controller board is installed, perform scanner manual registration (see [“Scanner manual registration” on page 265](#)), printhead registration (see [“Printhead assembly adjustments” on page 299](#)) and printer configuration restoration (see [“Restoring the printer configuration after replacing the controller board” on page 279](#)).

Controller board shield removal

- 1 Remove the right cover. See [“Right cover removal” on page 315](#).
- 2 Remove the optional hard disk, if present.
- 3 Loosen the two screws (A) securing the shield to the front of the printer frame.



- 4 Remove the screw (B) on the top left side of the shield.

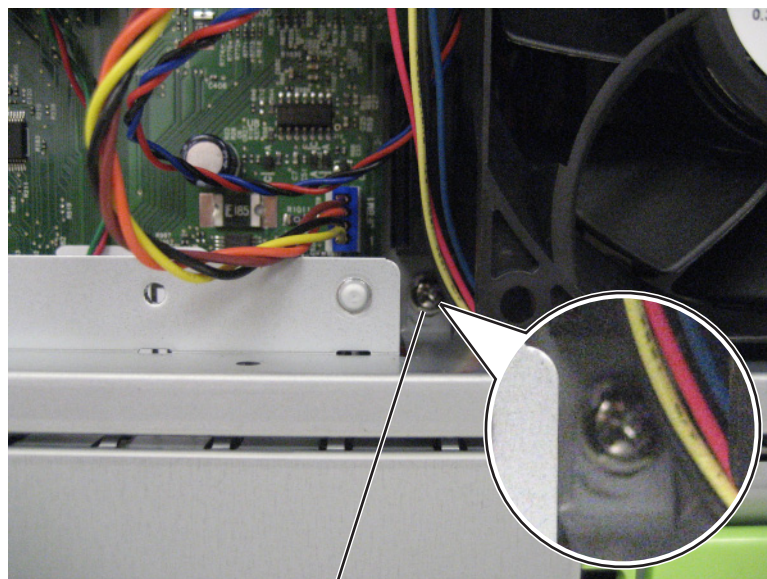

B

- 5 Remove the screw (C) on the top right side of the shield.



C

- 6 Carefully remove the controller board shield from the printer.

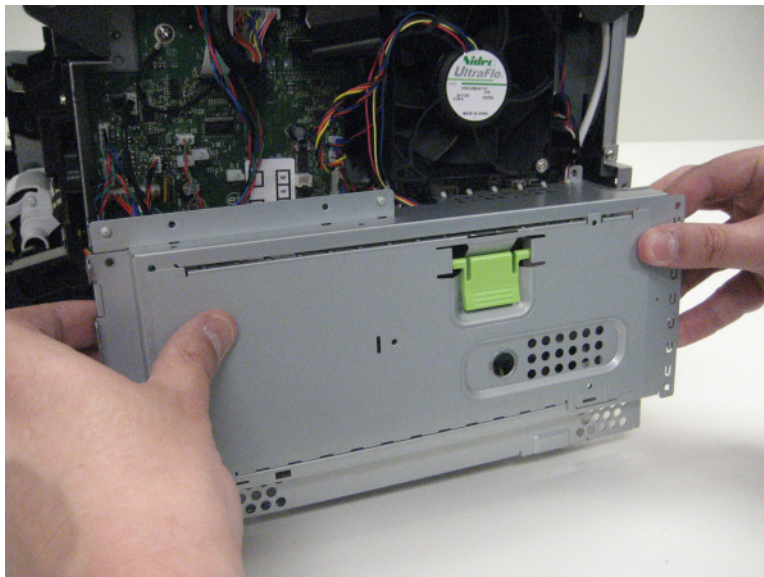

Toner cartridge smart chip contact removal

- 1 Remove the right cover. See [“Right cover removal” on page 315.](#)
- 2 Remove the controller board shield. See [“Controller board shield removal” on page 322.](#)
- 3 Remove the controller board. See [“Controller board removal” on page 320.](#)
- 4 Remove the two screws (A).

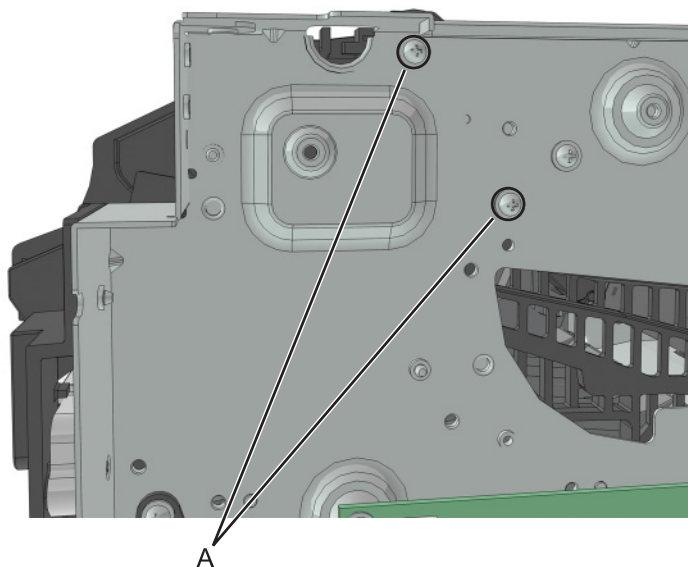

- 5 Remove the two screws (B), and then detach the right cartridge guide.

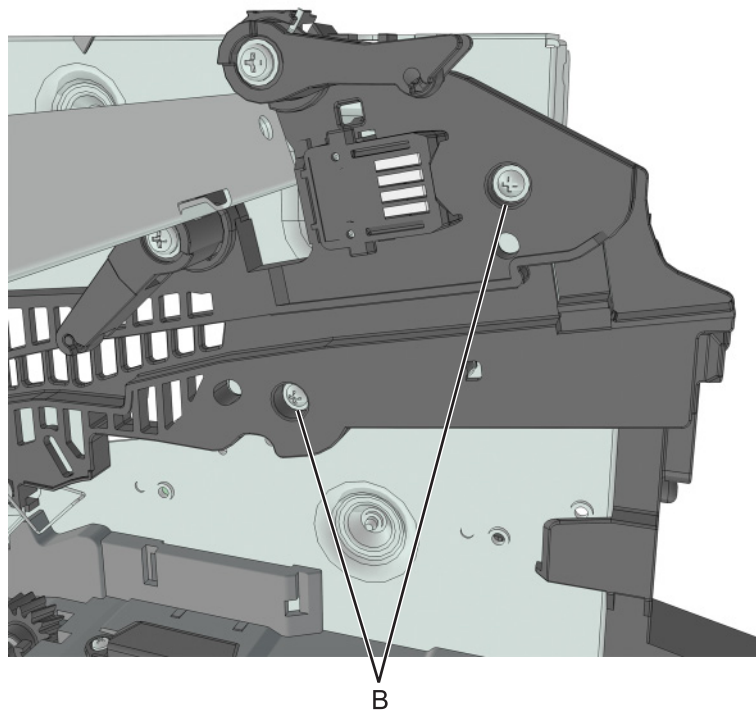

- 6 From behind the right cartridge guide, release the 4 latches (C) to detach the toner cartridge smart chip contact.

Note: Pay attention to the original position of the spring and the actuators.

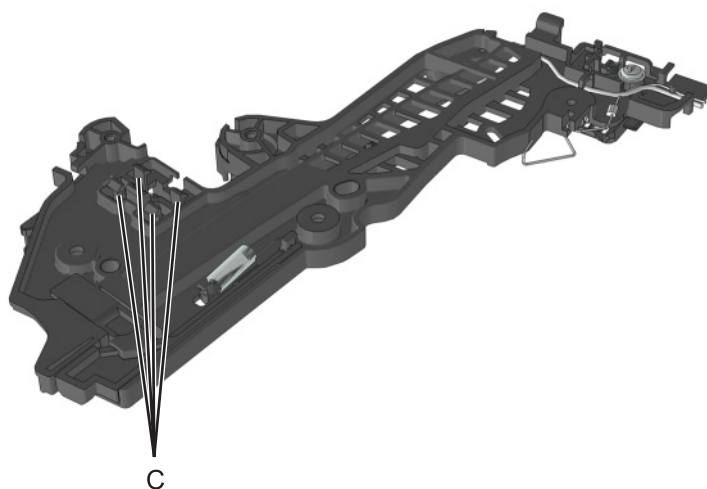

Installation notes:

- a Test for proper installation of the spring and the actuators.
- b Press the cartridge actuator. The cartridge lock should move up.

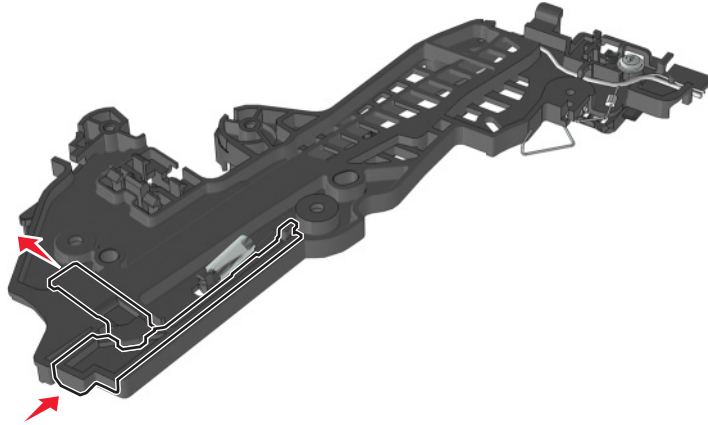

- c Release the cartridge actuator. The cartridge lock should move back to its original position.

Modem removal

- 1 Remove the right cover. See [“Right cover removal” on page 315.](#)
- 2 Remove the controller board shield. See [“Controller board shield removal” on page 322.](#)
- 3 Disconnect the modem connector (JFAX1) from the controller board.



- 4 Loosen the two screws (A) securing the modem to the controller board shield.



- 5 Lift the modem to release, and then remove.



Front side removals

Left front mount removal

- 1 Remove the left cover. See [“Left cover removal” on page 302](#).
- 2 Remove the front access cover. See [“Front access cover removal” on page 354](#).

- 3 Remove the three screws (A), and then remove the left front mount.

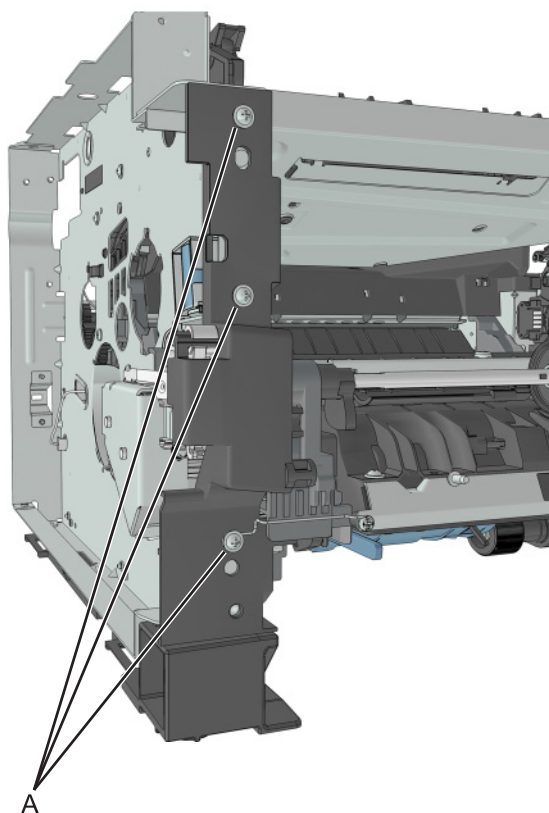

Right front mount removal

- 1 Remove the right cover. See [“Right cover removal” on page 315.](#)
- 2 Disconnect all control panel cables from the controller board.
- 3 Disconnect the cable JCVR1 from the controller board.

4 Remove the four screws (B), and then remove the right front mount.

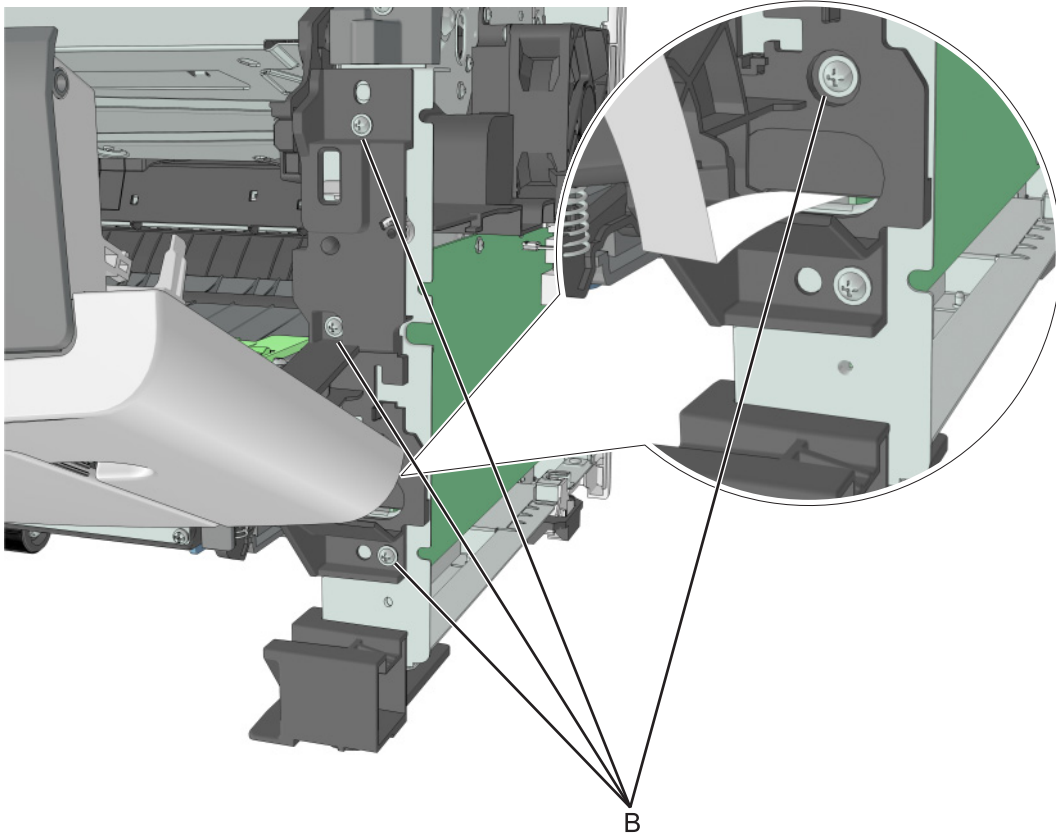

Transfer roll removal

Warning—Potential Damage: Do not touch the transfer roll with bare hands. Oil from the skin can damage it.

- 1 Squeeze the latches at each end of the transfer roll.

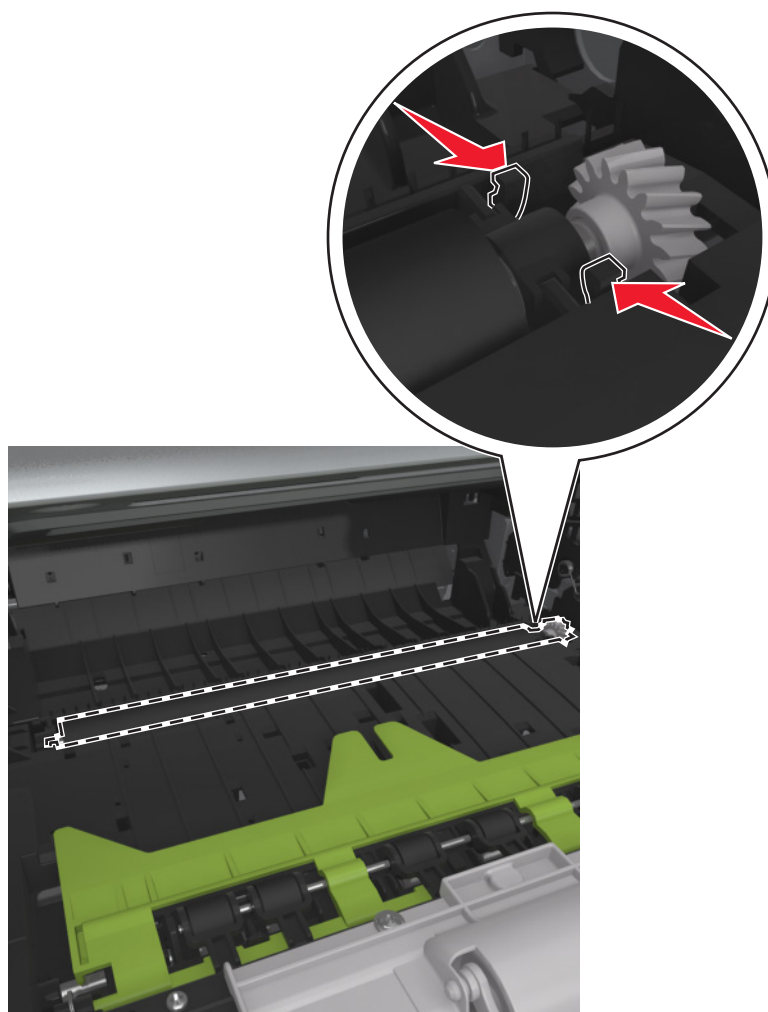

- 2 Lift to remove the transfer roll.

Warning—Potential Damage: Do not remove the spring under the left latch. Doing so will damage the printer.

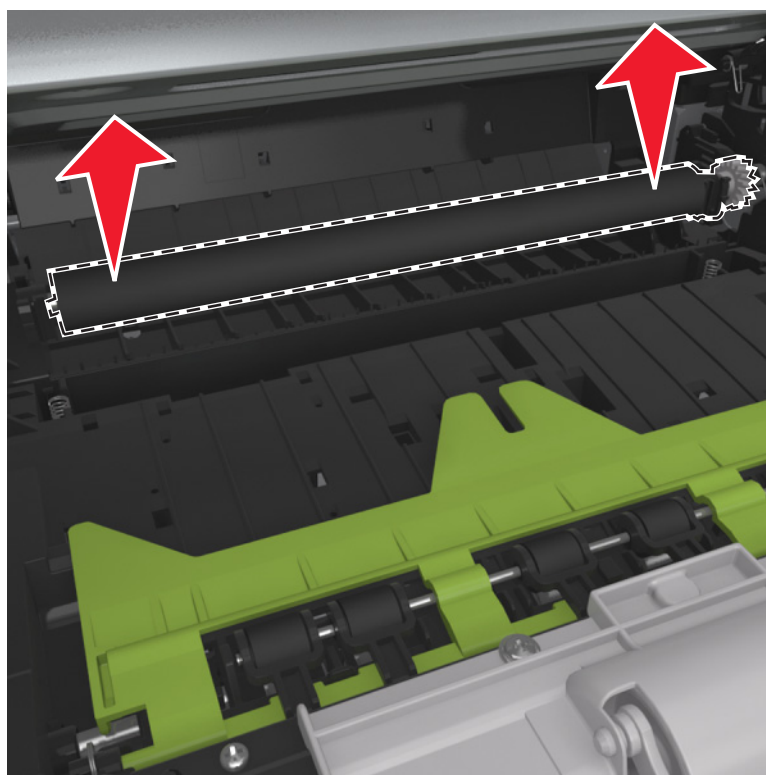

Cartridge plunger removal

- 1 Open the front door.
- 2 Tilt the cartridge plunger.

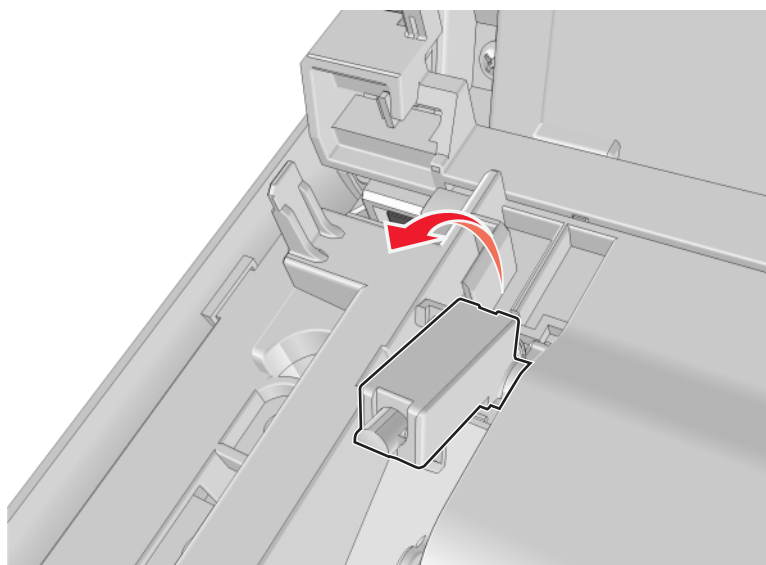

- 3** Twist and then remove the cartridge plunger.

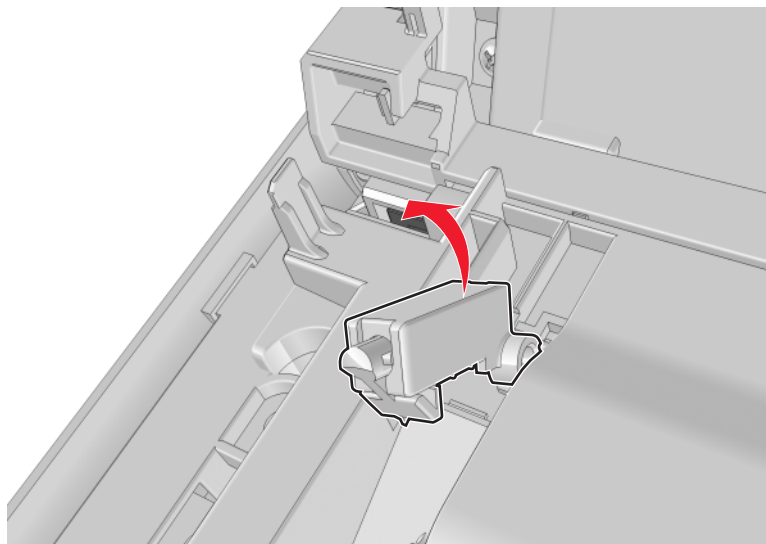

Installation notes:

- a** Use a spring hook to hold the spring, and then reinstall the cartridge plunger.

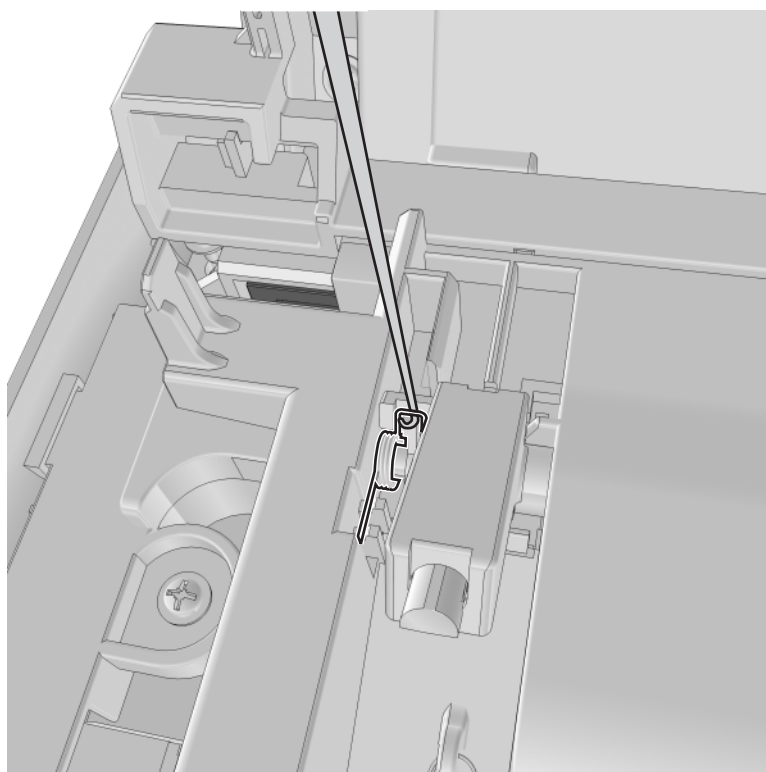

- b** Set the spring over the plunger.

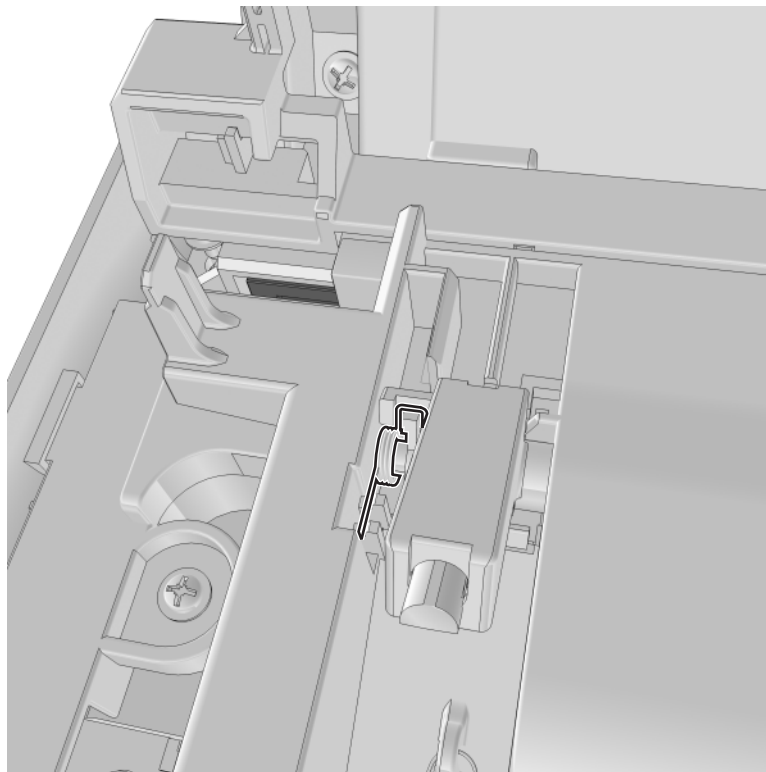

Name plate cover removal

- 1 Open the front door.
- 2 Remove the two screws (A) securing the right side of the name plate cover.

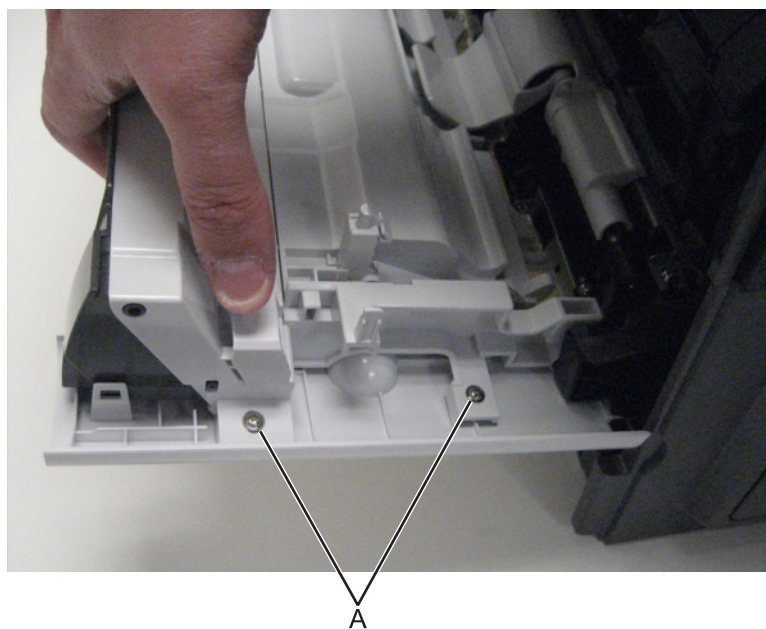

Parts removal

- 3** Remove the two screws (B) securing the left side of the name plate cover.

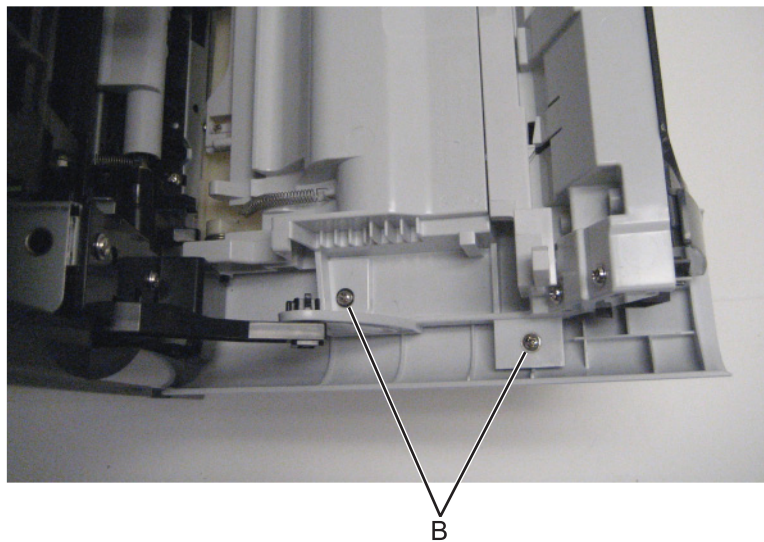

- 4** Release the tabs on top of the cover, and then remove the name plate cover.

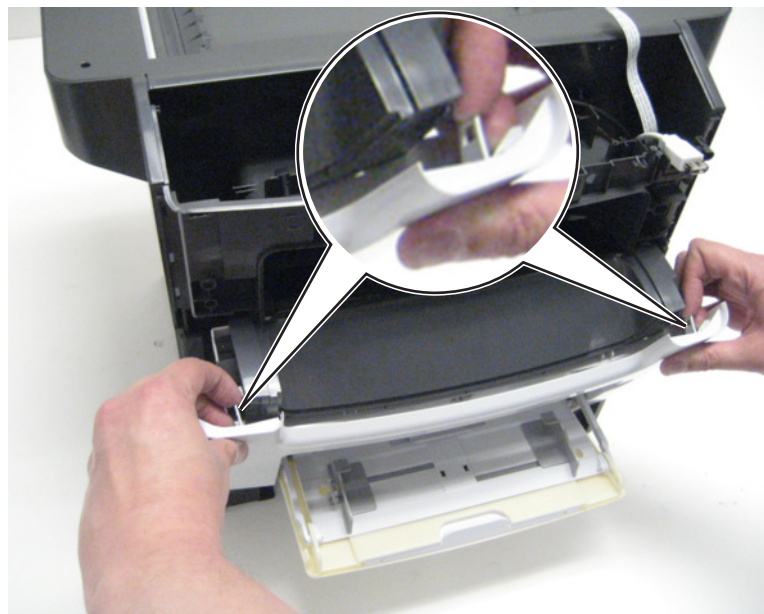

Front bin cover removal

- 1 Remove the name plate cover. See [“Name plate cover removal” on page 333](#).
- 2 Remove the two screws (A) securing the front bin cover to the front access cover.

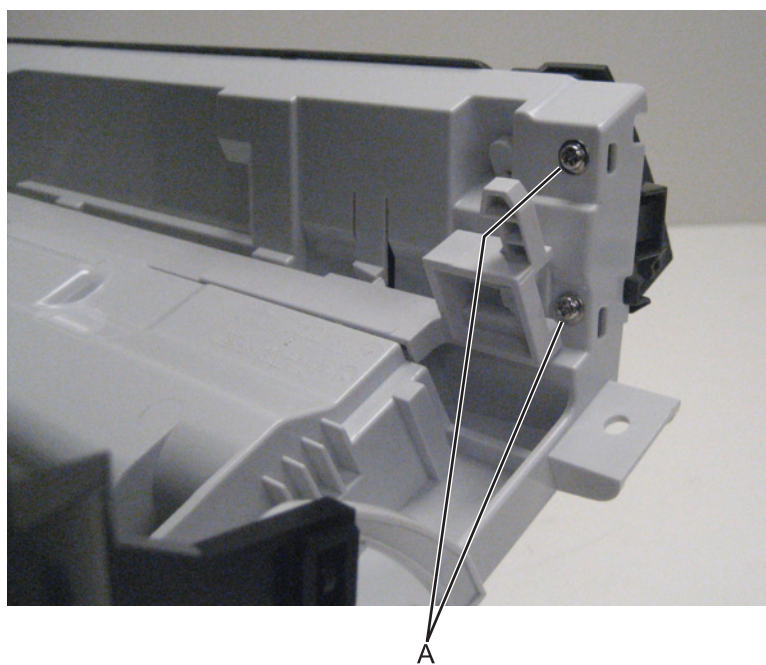

- 3 Lift the left side of the cover, and then remove the front bin cover.

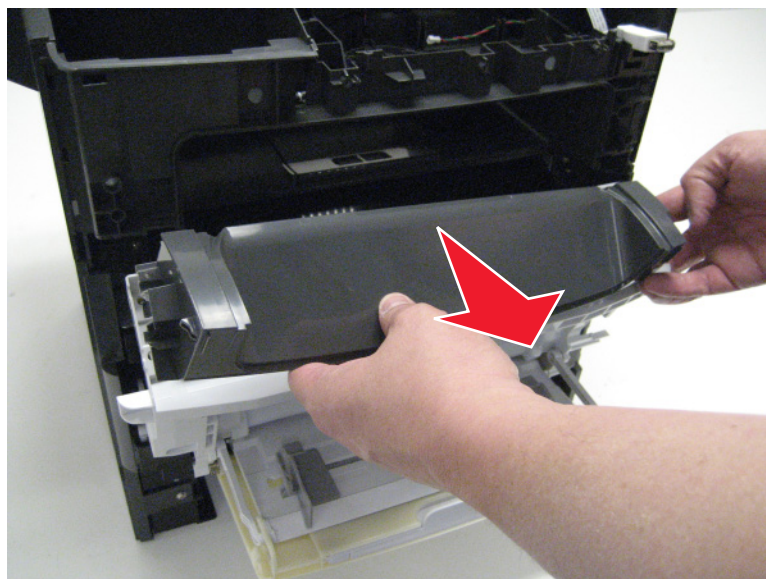

Control panel assembly removal

- 1 Open the wireless card cover.



- 2 Lift the display to access the latch.

- 3 Press the latch (A) to release the display from the panel mount.

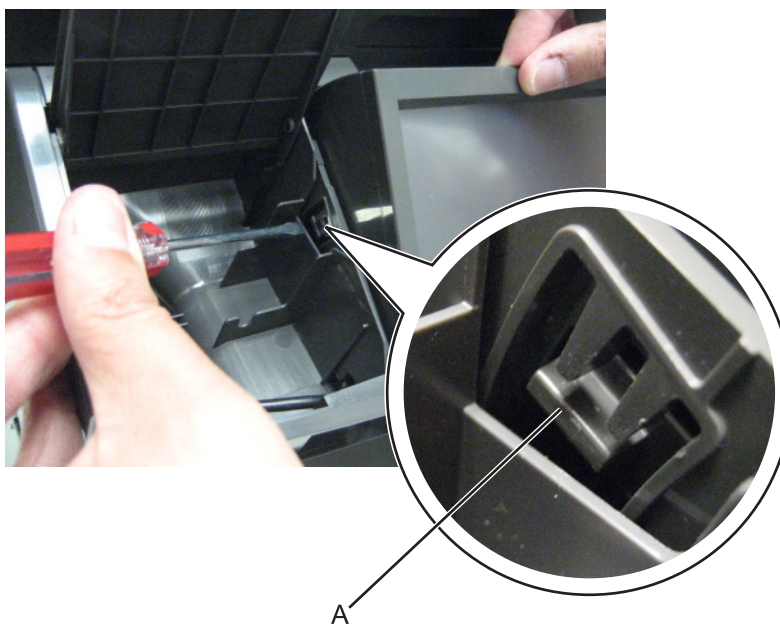

- 4 Position the display at the angle shown to access the screws behind it.



- 5 Remove the two screws (B) behind the display.

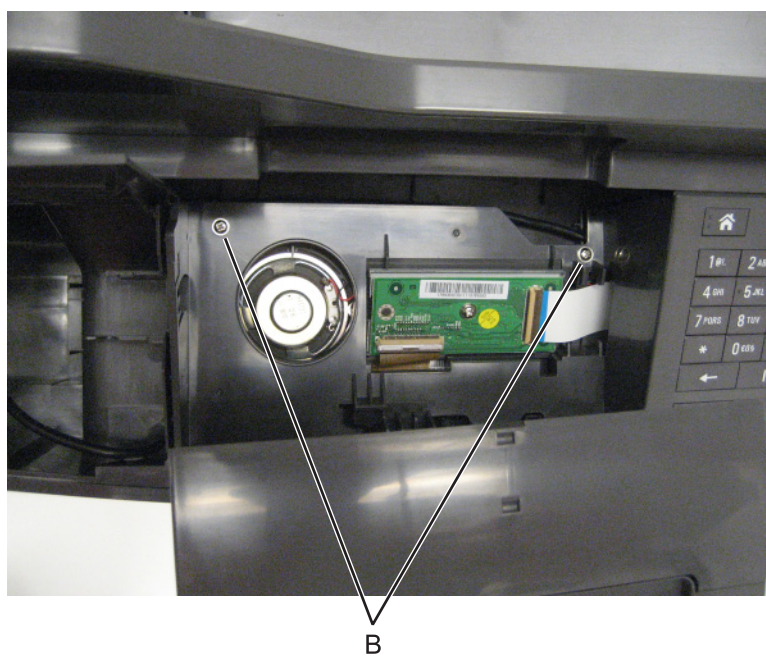

- 6** Remove the two screws (C) securing the control panel assembly to the scanner assembly.



- 7** Gently flex the wireless chamber wall to the left to release and lift the control panel assembly upward to remove it from the scanner assembly.

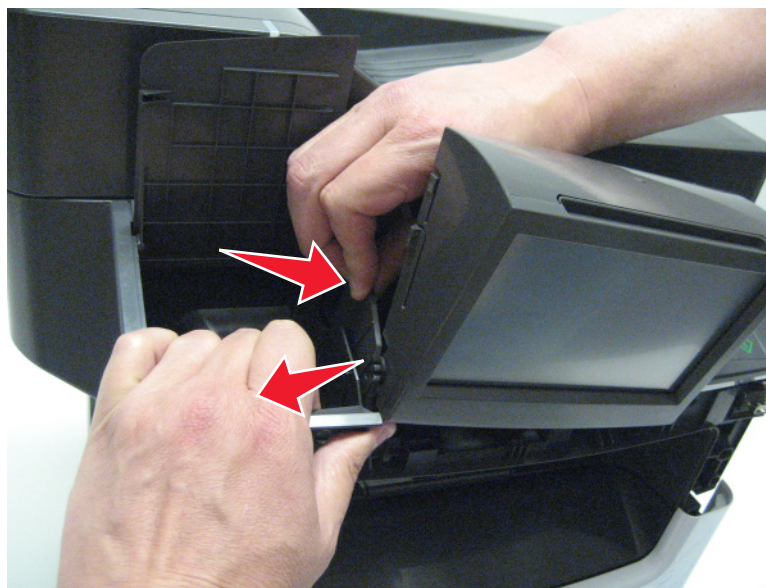

- 8 Remove the two screws (D) securing the toroid bracket to the control panel cover.

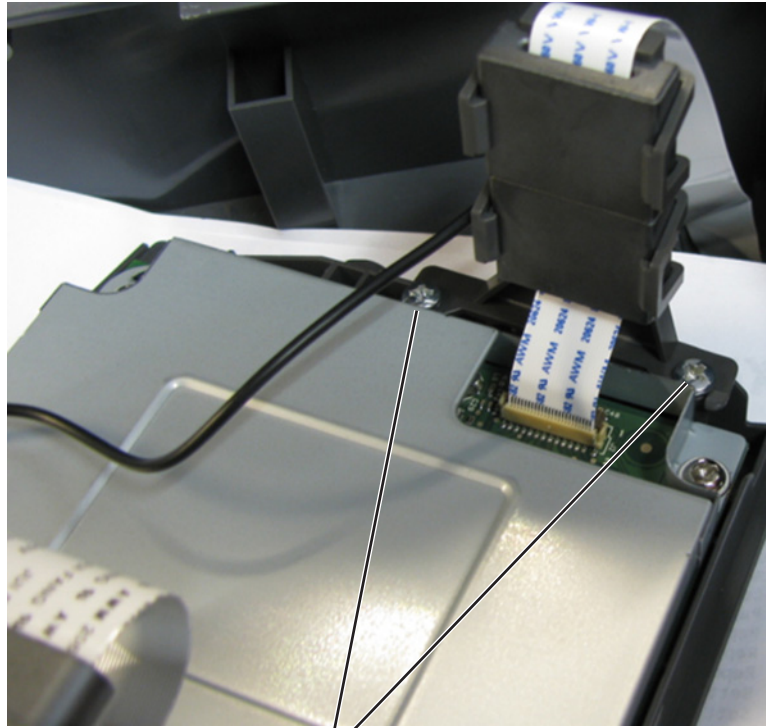

D

- 9 Unlock the connector (E) on the UICC and disconnect it from the UICC.

Warning—Potential Damage: The ZIF connector is prone to damage. Extra care is required in handling this part.



E

UICC removal

- 1 Remove the control panel assembly. See [“Control panel assembly removal” on page 336](#).
- 2 Position the display at the angle shown, to access the card behind it.



- 3 Disconnect the UICC video cable (A) from the interface card.

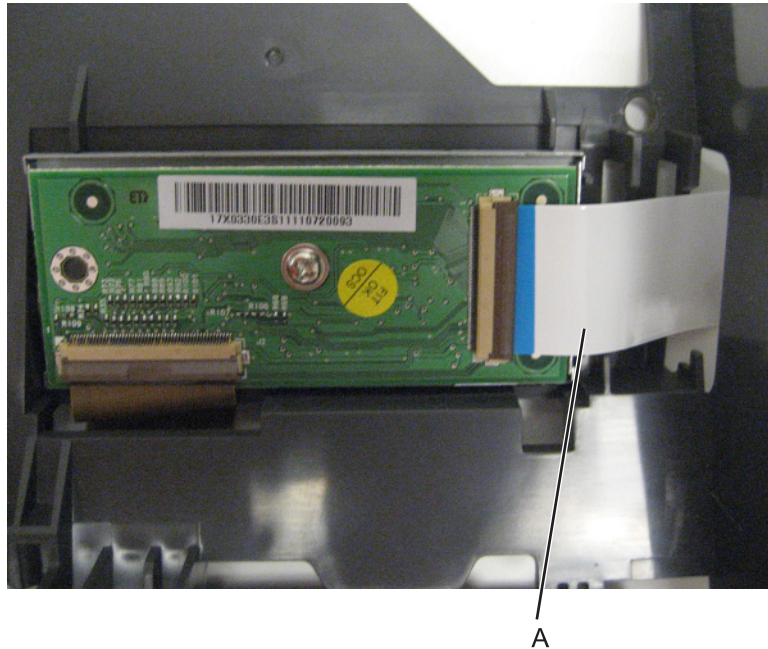

- 4 Place the control panel assembly facedown on a non-marring surface.

- 5 Remove the four screws (B), then remove the UICC drip pan from the control panel assembly.

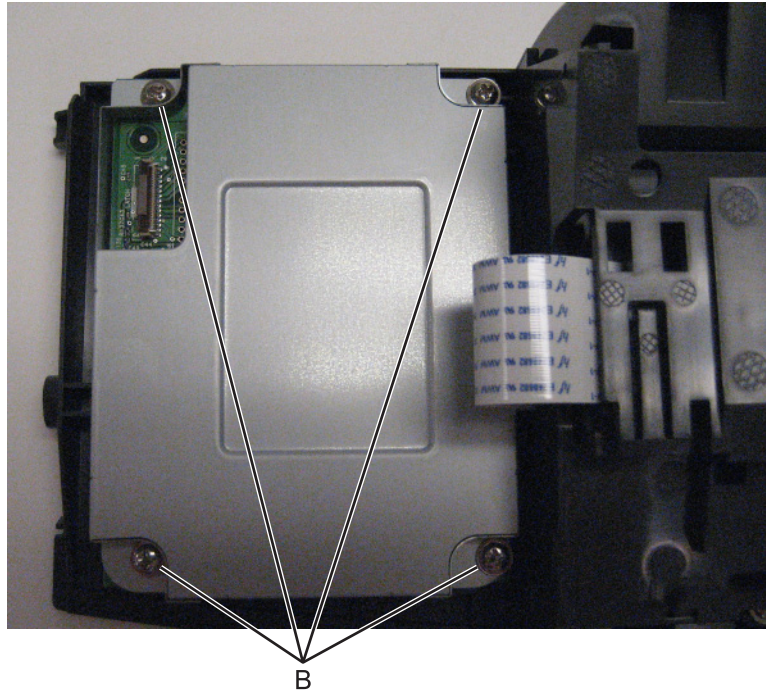

- 6 Disconnect the UICC video cable from the UICC card.

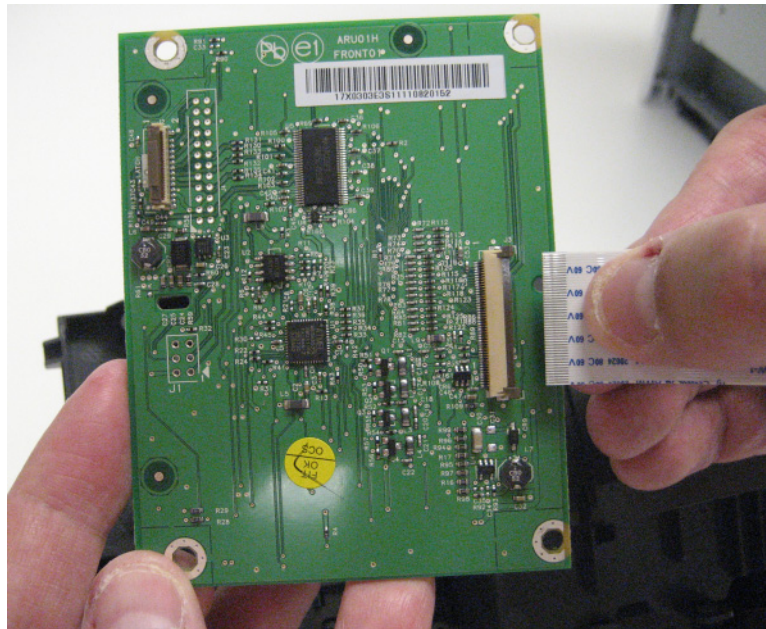

USB cable bracket removal

- 1 Remove the two screws (A).

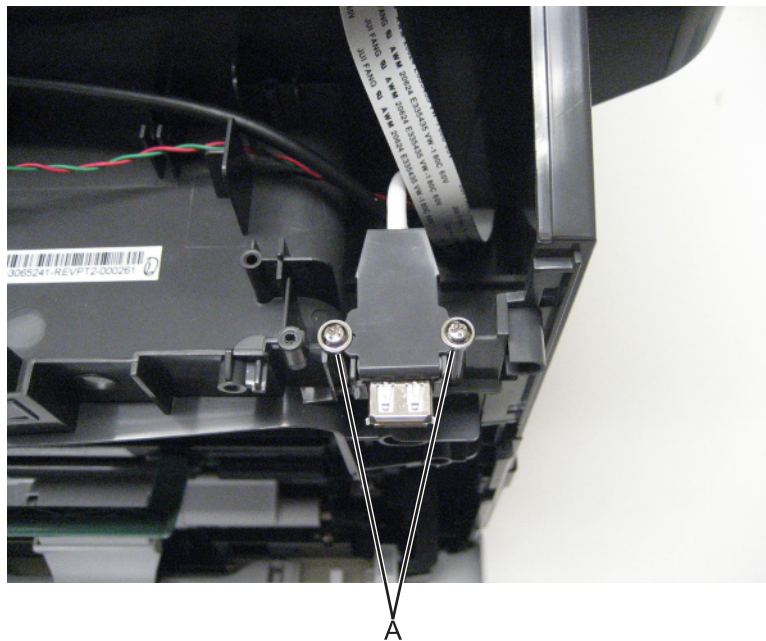

- 2 Remove the USB cable bracket.

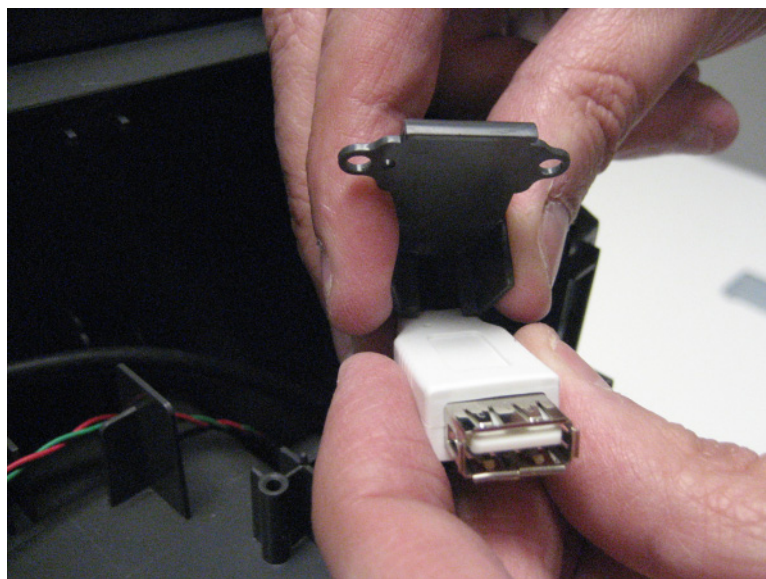

Speaker removal

- 1 Remove the control panel assembly. See [“Control panel assembly removal” on page 336.](#)
- 2 Unplug the connector (A) from the speaker.

- 3 Remove the screw (B) from the speaker.

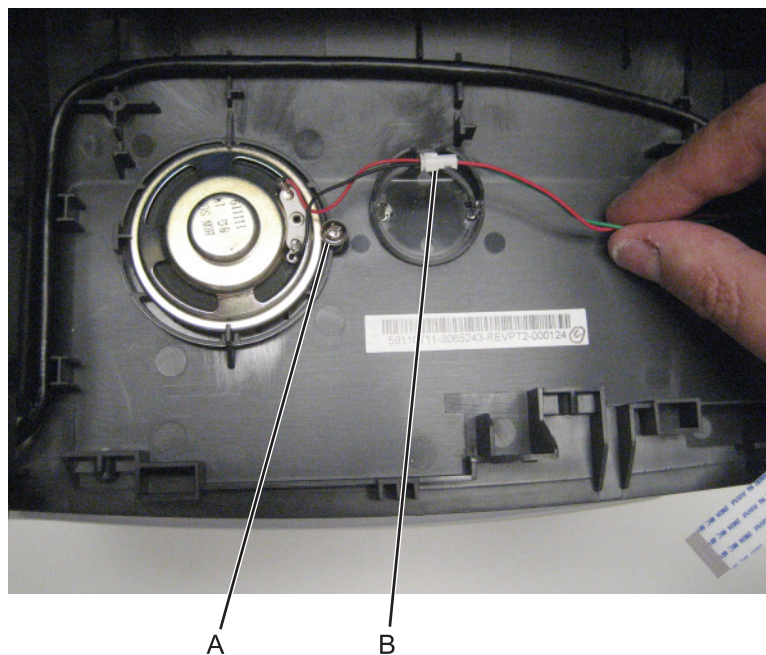

- 4 Gently slide the speaker to the right, and remove it from the scanner assembly.

Cave light lens removal

- 1 Remove the control panel assembly. See [“Control panel assembly removal” on page 336.](#)
- 2 Push the latches inward, and push down on the cave light lens to remove it from the scanner assembly.

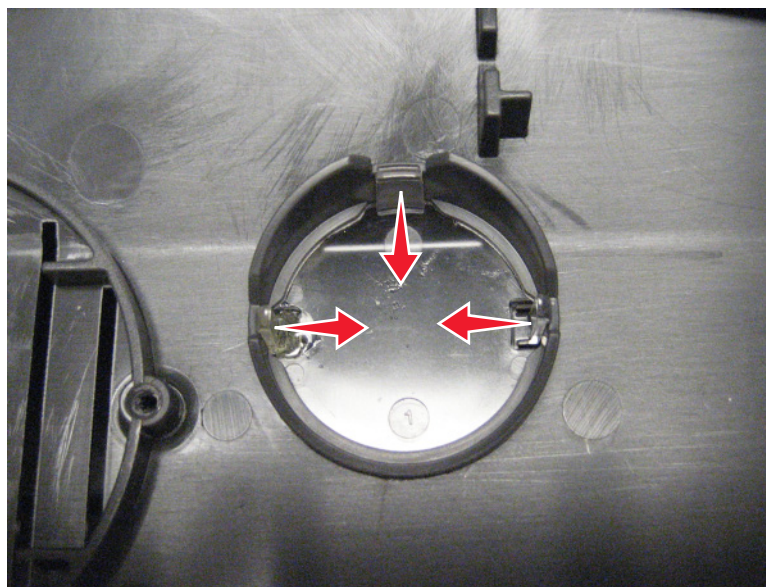

Installation warning: Gently push the left and right latches together while inserting the lens into the slot to avoid breaking the latches.

Interface card removal

- 1 Open the wireless cover.



- 2 Position the display at the angle shown, to access the card behind it.



- 3 Unlock the two connectors (A) on the interface card to release and then disconnect the UICC video and display cables (A).

- 4 Remove the screw (B), then remove the interface card.

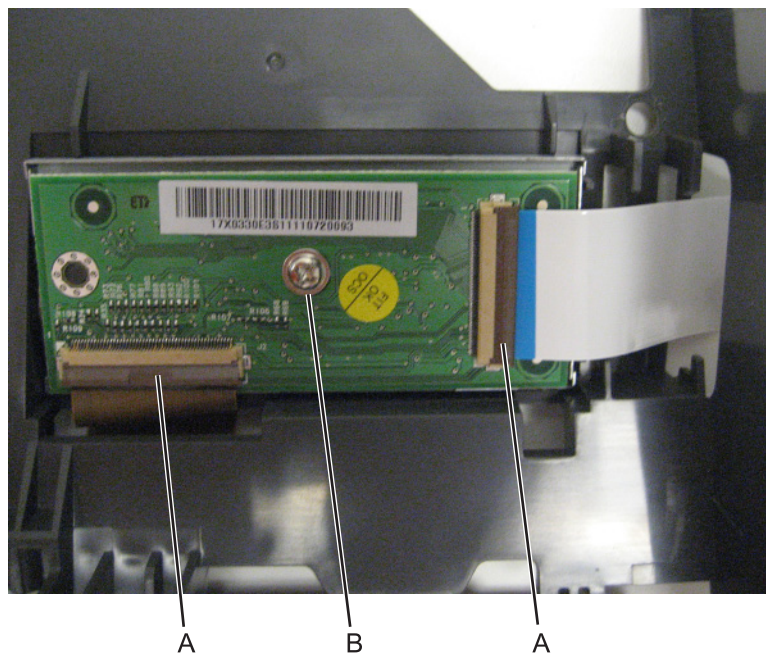

Control panel cover removal

- 1 Flex the frame to the right to release the hinge of the cover.



- 2 Remove the control panel cover.



Display removal

- 1 Remove the control panel assembly. See [“Control panel assembly removal” on page 336.](#)
- 2 Position the display at the angle shown, to access the card behind it.



- 3** Disconnect the display cable (A) from the interface card.

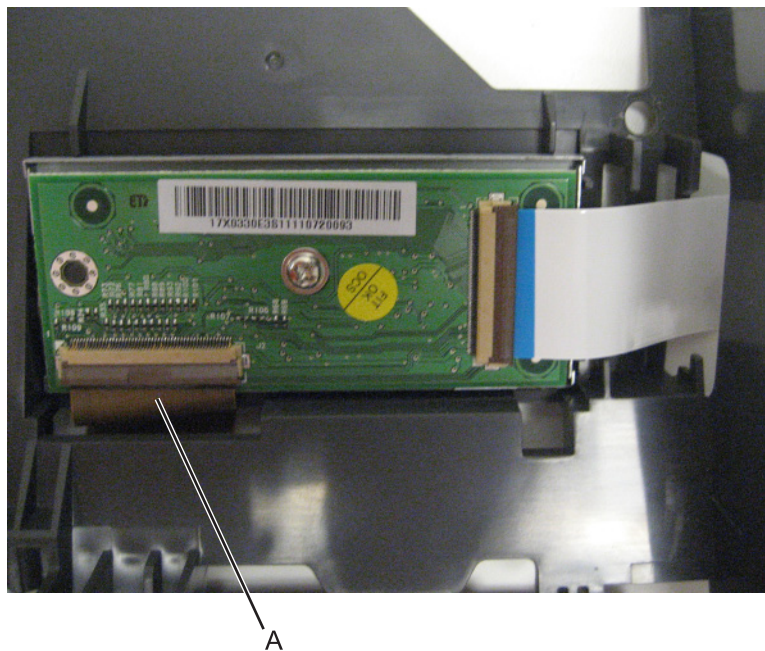

- 4** Release the two tabs (B) fastening the display bezel, then separate both the display and bezel from the display assembly.

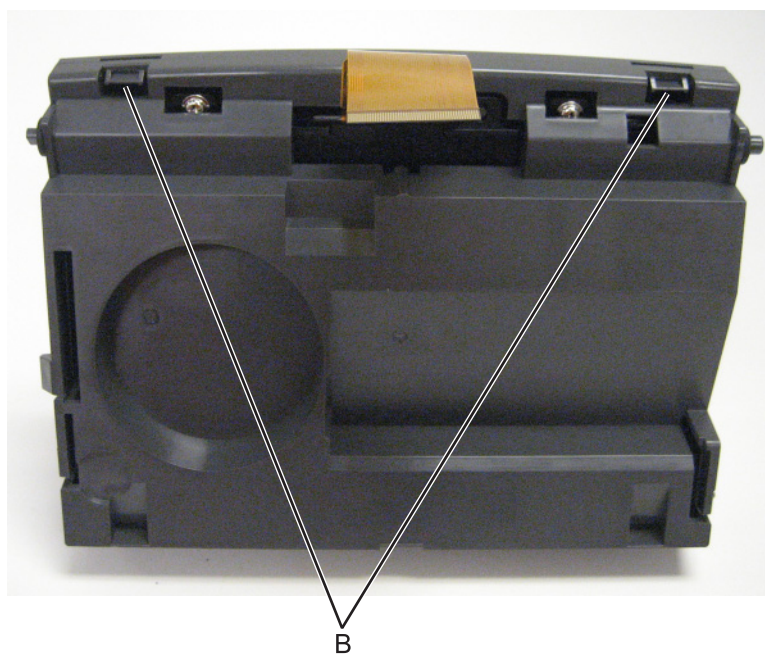

- 5** Place the display and bezel facedown on a non-marring surface.

- 6 Remove the four screws (C).

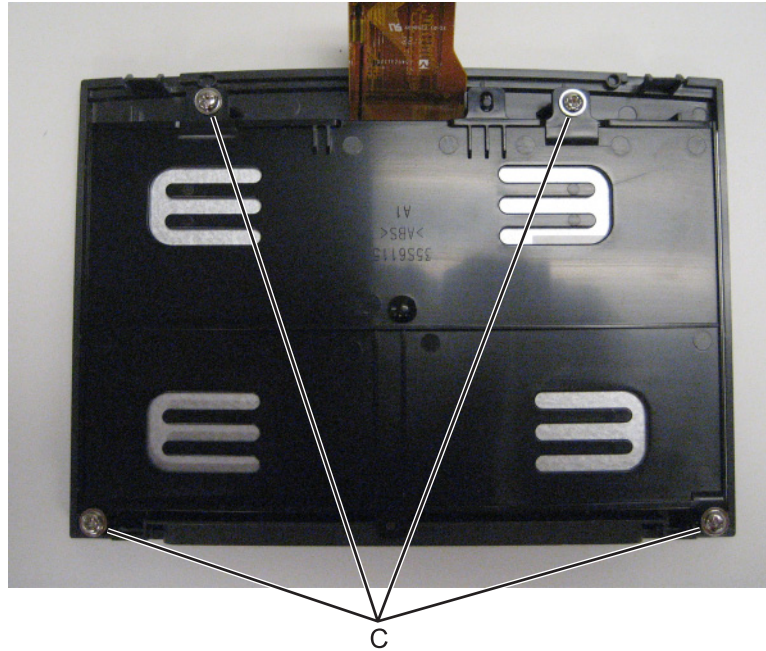

- 7 Remove the plastic mounting bracket, and remove the display from the LED bezel.

Keypad assembly removal

- 1 Remove the control panel assembly. See [“Control panel assembly removal” on page 336.](#)
- 2 Remove the UICC. See [“UICC removal” on page 340.](#)
- 3 Remove the display. See [“Display removal” on page 346.](#)
- 4 Remove the interface card. See [“Interface card removal” on page 344.](#)
The keypad assembly remains.

MPF tray removal

- 1 Remove the front access cover. See [“Front access cover removal” on page 354](#).
- 2 Using a spring hook, remove the two springs from the front access cover.

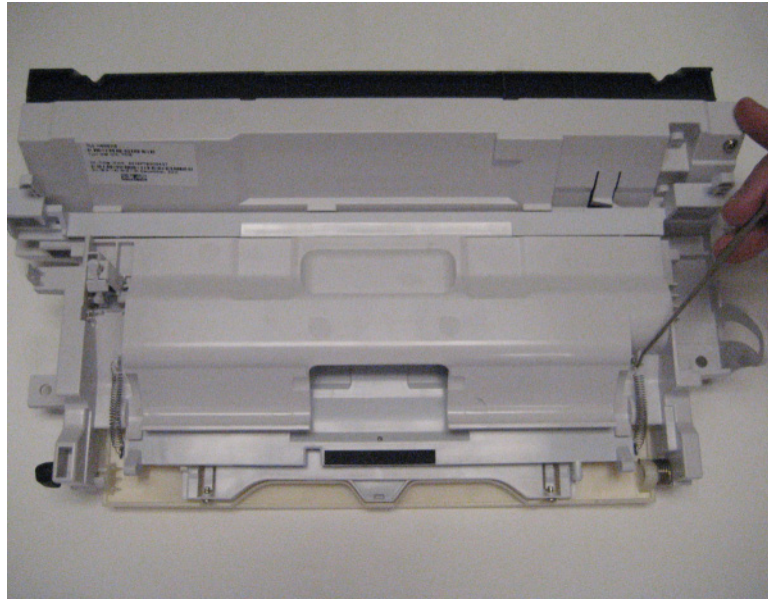

- 3 Disconnect the left and right MPF links from the front access cover.

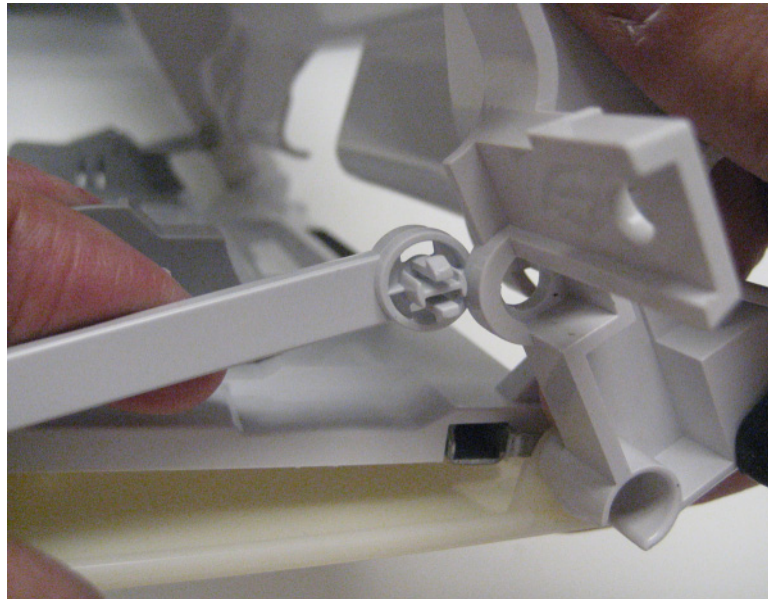

- 4 Push the MPF tray to the left to release the right pivot on the front access cover.

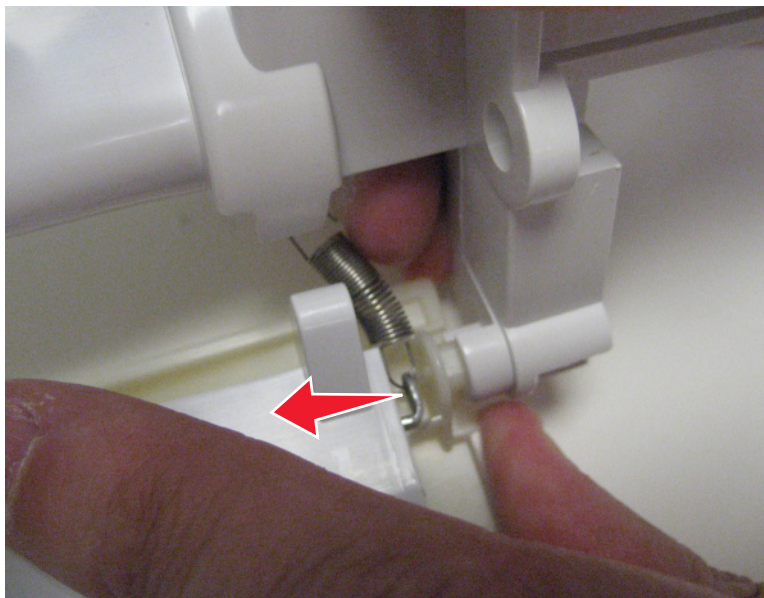

- 5 Slide the tray to the right, and remove the MPF tray and spring.

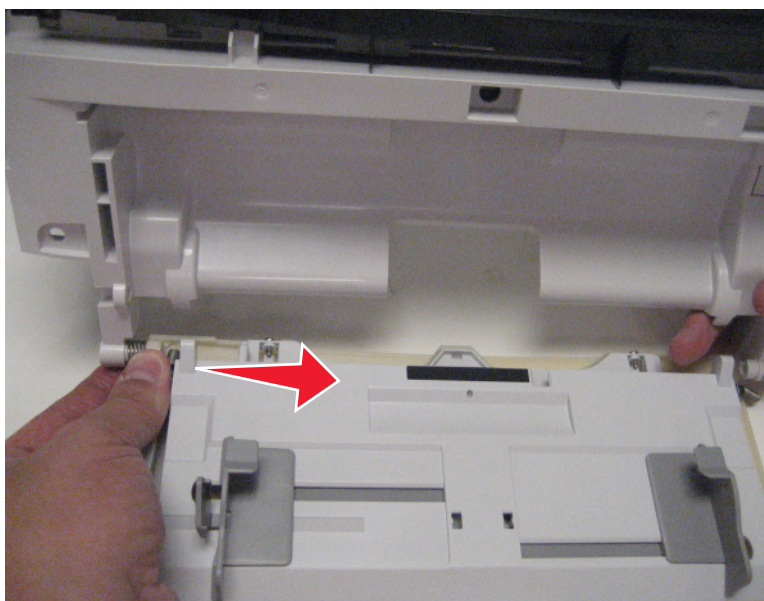

Installation note: Insert the straight end of the spring into the hole on the front access cover before sliding the MPF tray onto the left pivot of the front access cover.

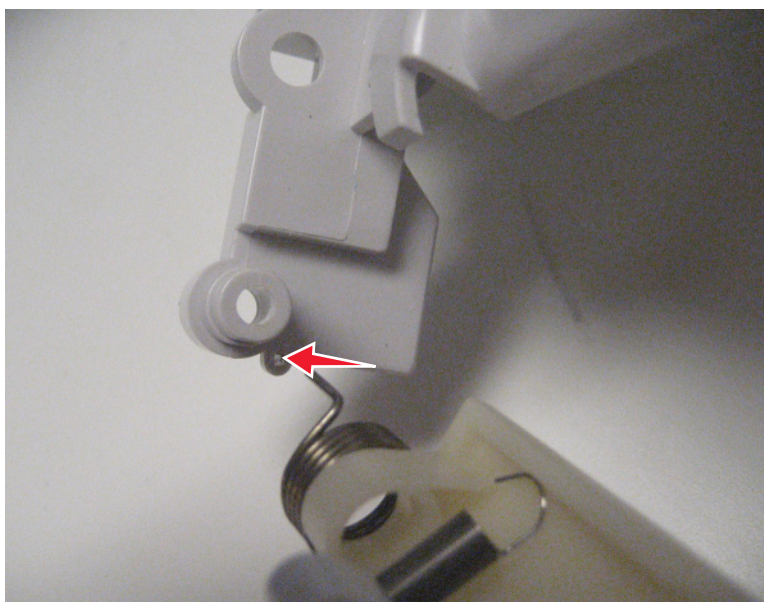

6 Remove the tray link arm from the MPF tray.

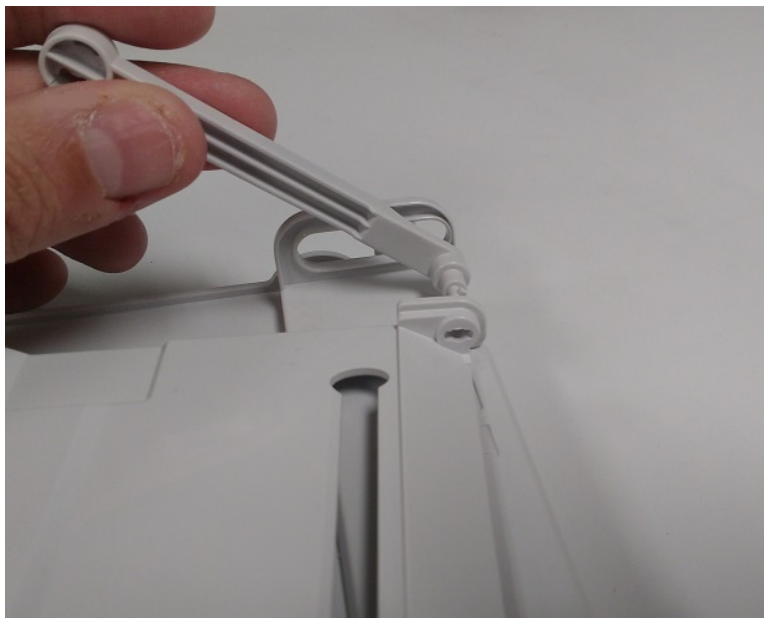

MPF pick roller cover removal

- 1 Open the front door.
- 2 Remove the two screws (A), and then remove the MPF pick roller cover.

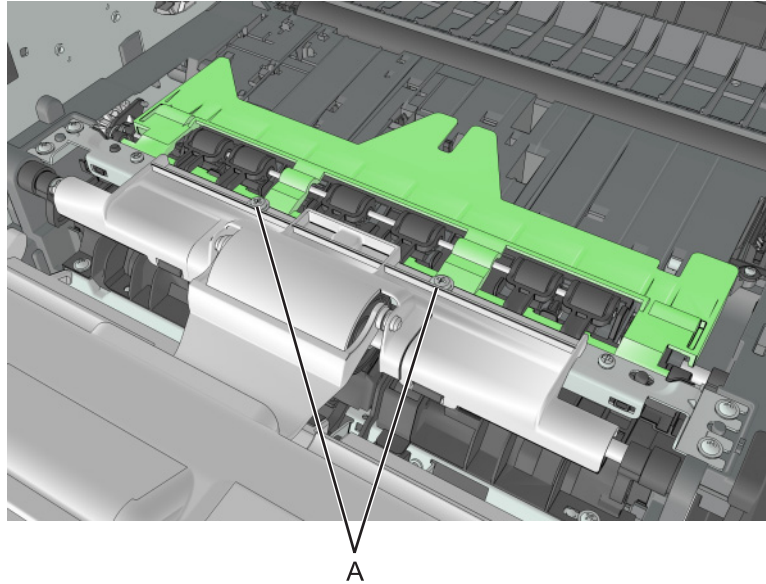

MPF pick roller removal

- 1 Remove the MPF pick roller cover. See [“MPF pick roller cover removal” on page 352](#).
 - 2 Remove the two screws (A).
- Note:** Use a #0 Phillips screwdriver.

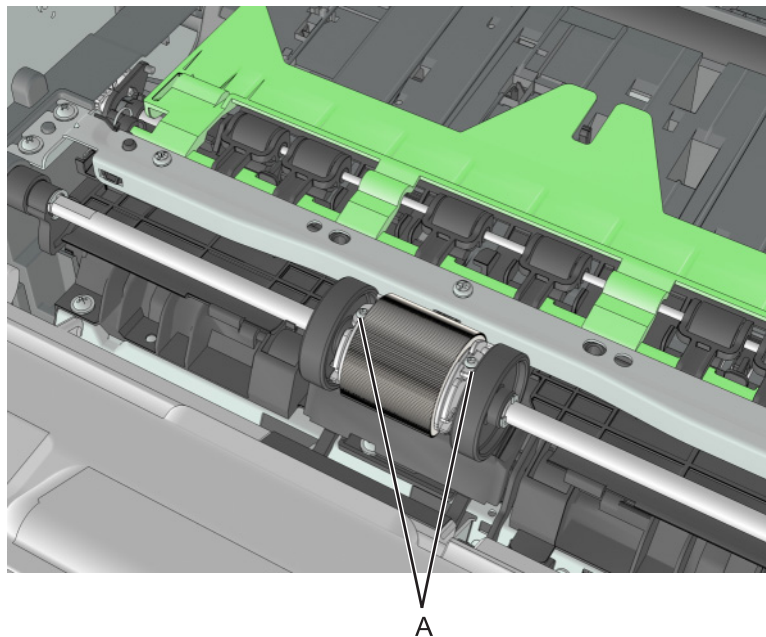

- 3 Pull the MPF pick roller outward to remove.

Warning—Potential Damage: Do not touch the pick tire with bare hands, as this can damage the pick roller.

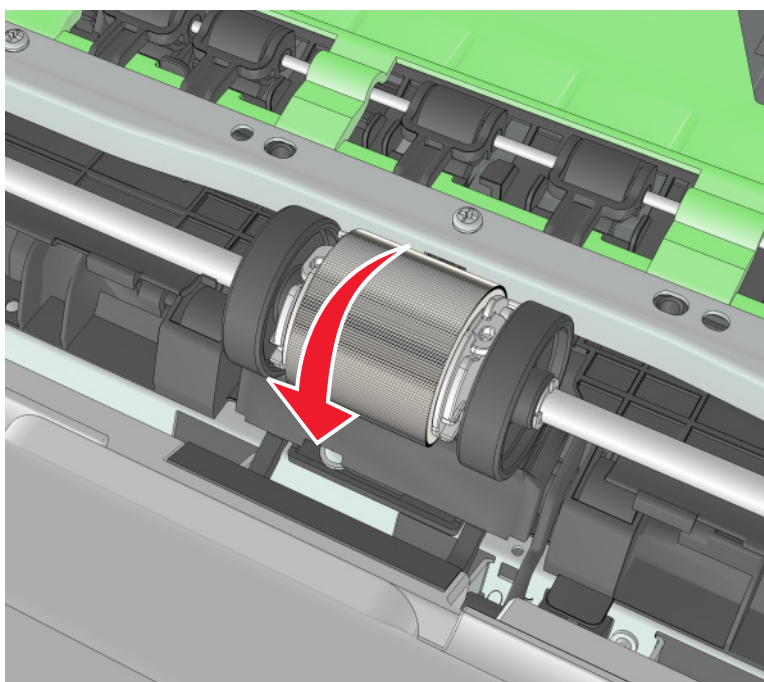

Bail removal

- 1 Remove the MPF pick roller cover. See [“MPF pick roller cover removal” on page 352.](#)
- 2 Rotate the bail.
- 3 Squeeze the latches, and then remove the bail.

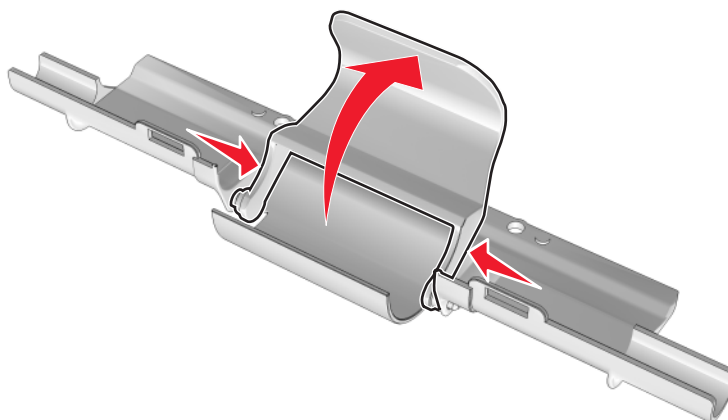

Jam access cover removal

- 1 Remove the MPF pick roller cover. See [“MPF pick roller cover removal” on page 352.](#)
- 2 Remove the MPF pick roller. See [“MPF pick roller removal” on page 352.](#)

- 3** Remove the four screws (A), and then remove the jam access cover.

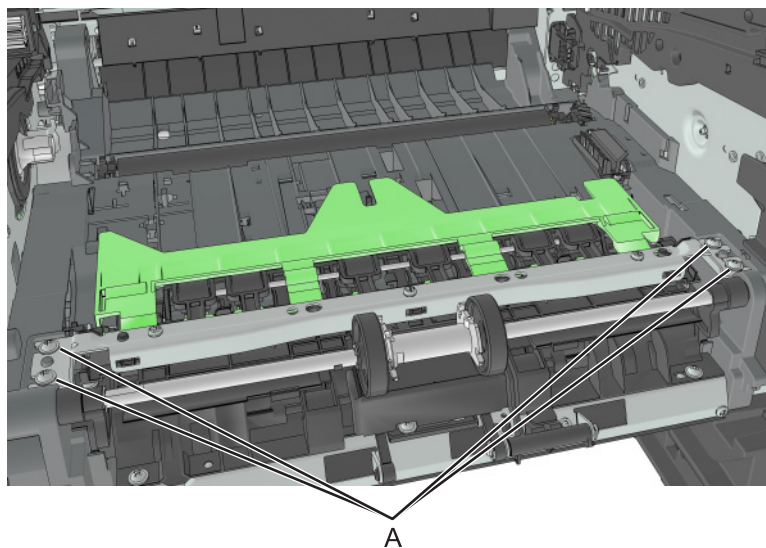

Front access cover removal

- 1** Remove the name plate cover. See [“Name plate cover removal” on page 333](#).
- 2** Disconnect the cartridge gear linkage (A) from the front access cover.

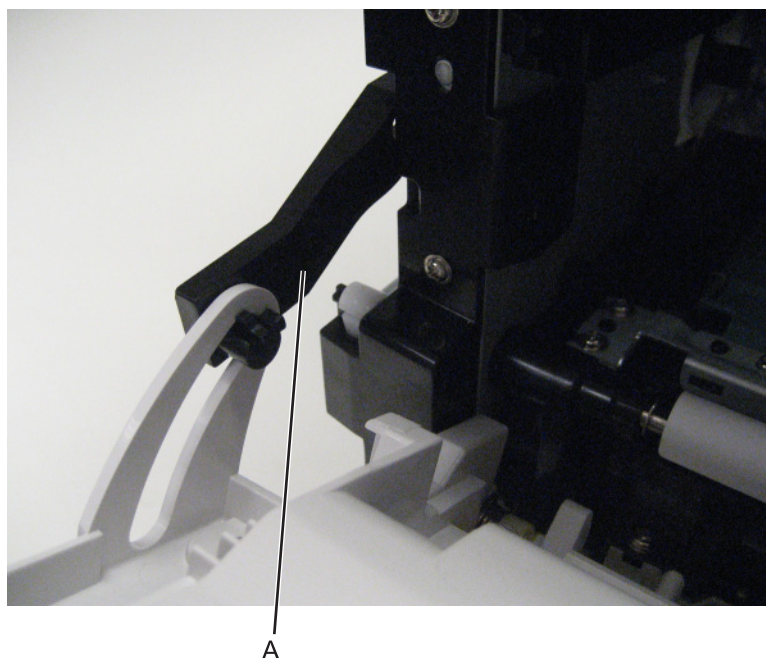

- 3** Rotate the front access cover to a position that aligns the gap on the cover with the right hinge.

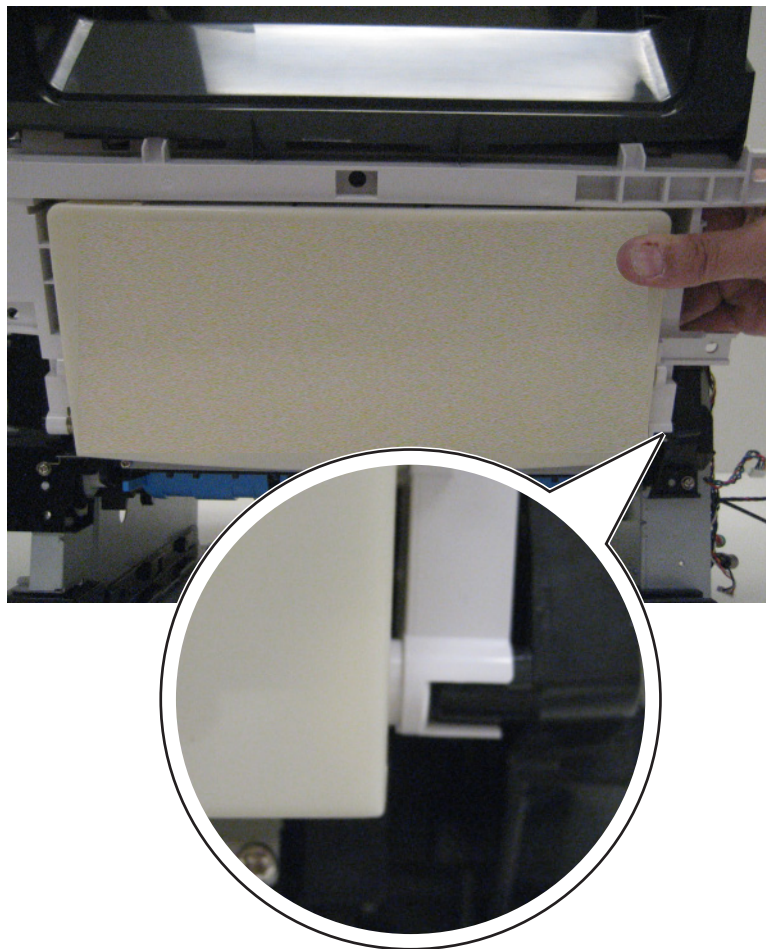

- 4** Release the right hinge off the pivot by lifting up on the right side of the front access cover.
- 5** Slide the front access cover to the right, removing it from the print engine.

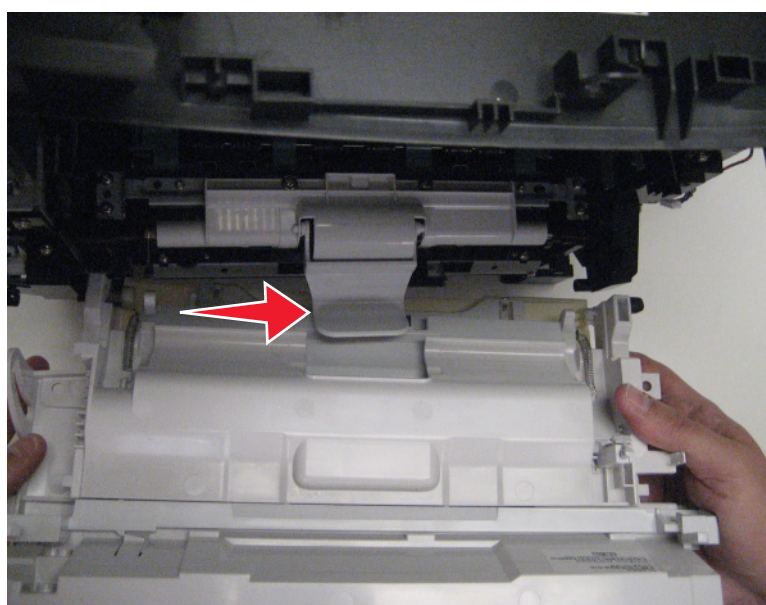

Parts removal

Front door sensor removal

- 1 Remove the front access cover. See [“Front access cover removal” on page 354.](#)
- 2 From under the right mount, remove the screw (A).

Note: Use a #1 Phillips screwdriver.

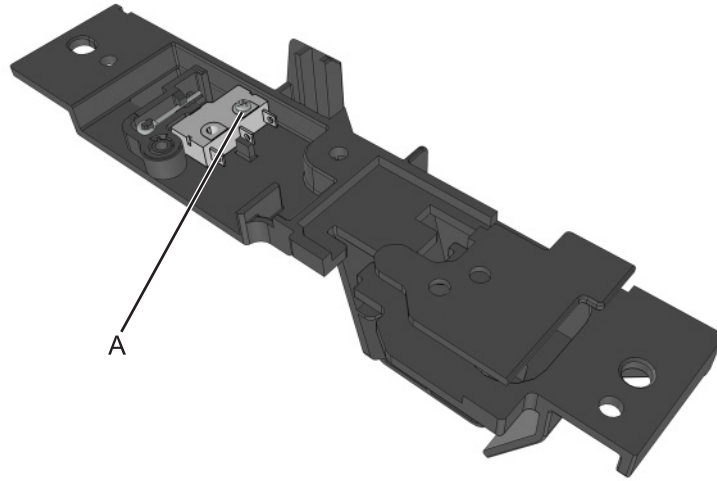

Front input guide removal

- 1 Remove the right cover. See [“Right cover removal” on page 315.](#)
- 2 Remove the MPF pick roller cover. See [“MPF pick roller cover removal” on page 352.](#)
- 3 Remove the MPF pick roller. See [“MPF pick roller removal” on page 352.](#)
- 4 Remove the jam access cover. See [“Jam access cover removal” on page 353.](#)
- 5 Remove the MPF tray. See [“MPF tray removal” on page 349.](#)
- 6 Disconnect cable JMPF1 from the controller board.

7 Remove the four screws (A).

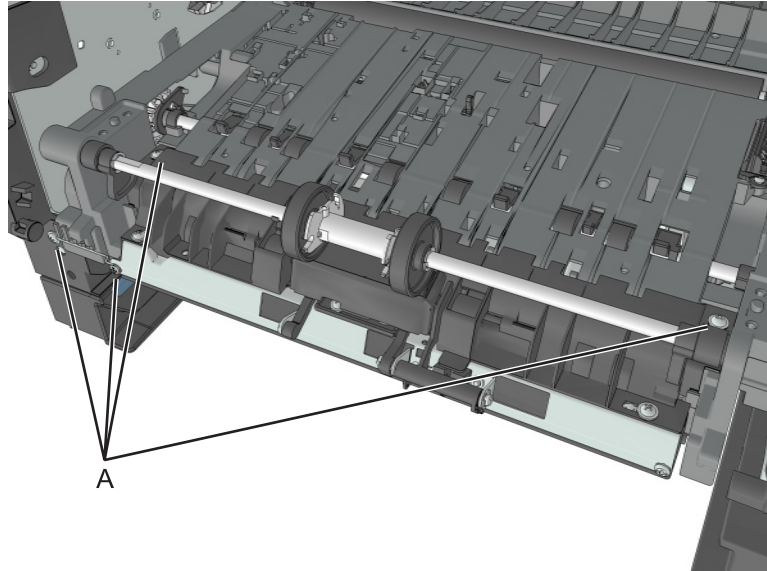

8 Push and hold the cam restraint to release the MPF shaft.

9 Rotate the MPF shaft inward so that the cams at each end point up.

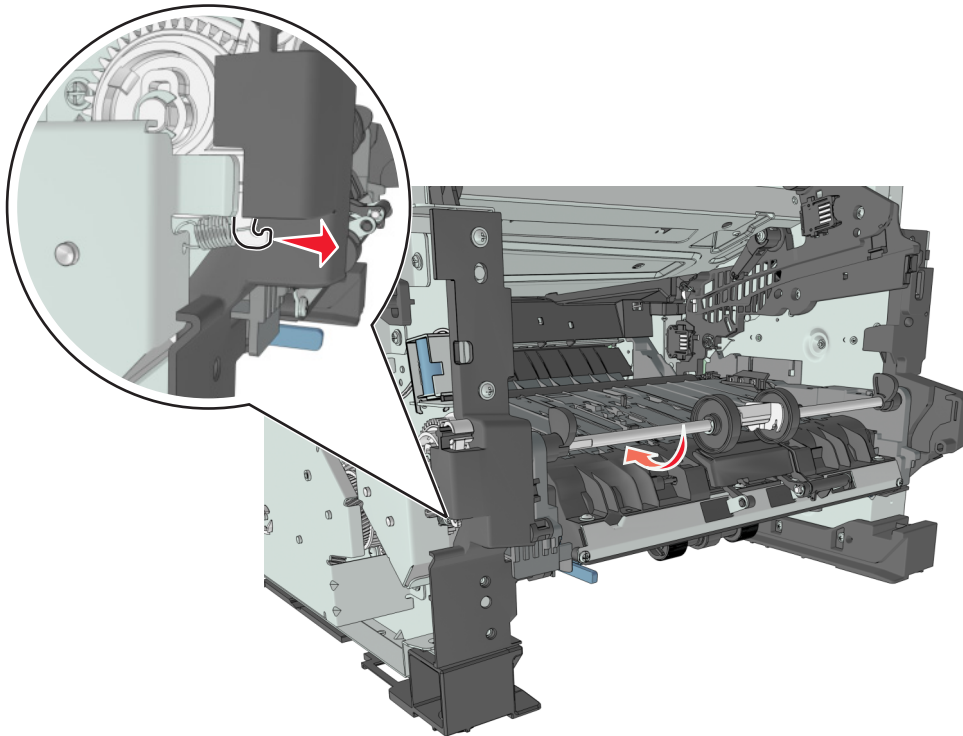

10 Release the front guide from the guides at each end.

Installation note: The cams at each end of the MPF shaft must point down.

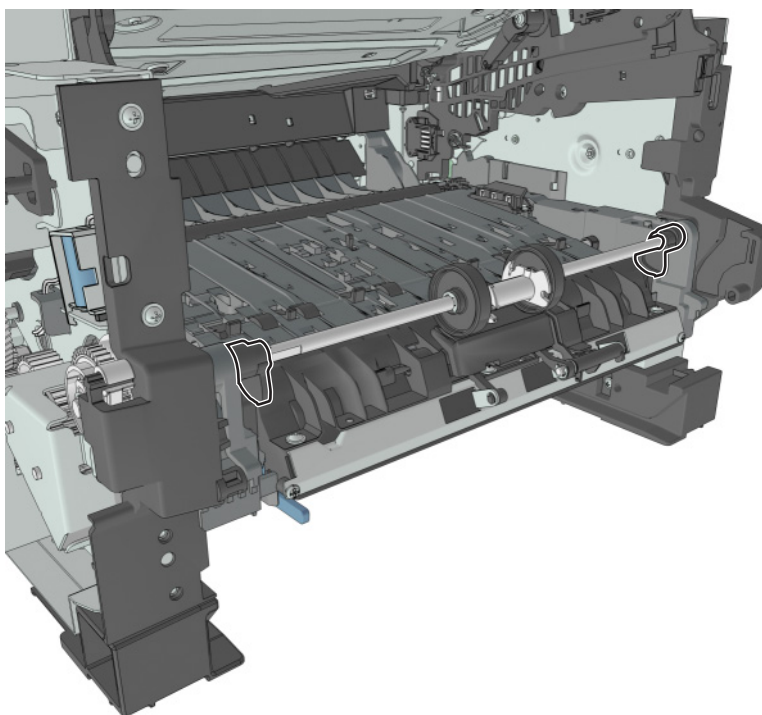

Separator pad removal

- 1 Remove the right cover. See [“Right cover removal” on page 315.](#)
- 2 Remove the front access cover. See [“Front access cover removal” on page 354.](#)
- 3 Remove the MPF pick roller cover. See [“MPF pick roller cover removal” on page 352.](#)
- 4 Remove the MPF pick roller. See [“MPF pick roller removal” on page 352.](#)
- 5 Remove the jam access cover. See [“Jam access cover removal” on page 353.](#)
- 6 Remove the E-clip (A).

- 7** While pressing down the MPF sensor flag (B) and separator pad (C), move the restraint roller (D) and MPF pick roller hub (E) to the right.

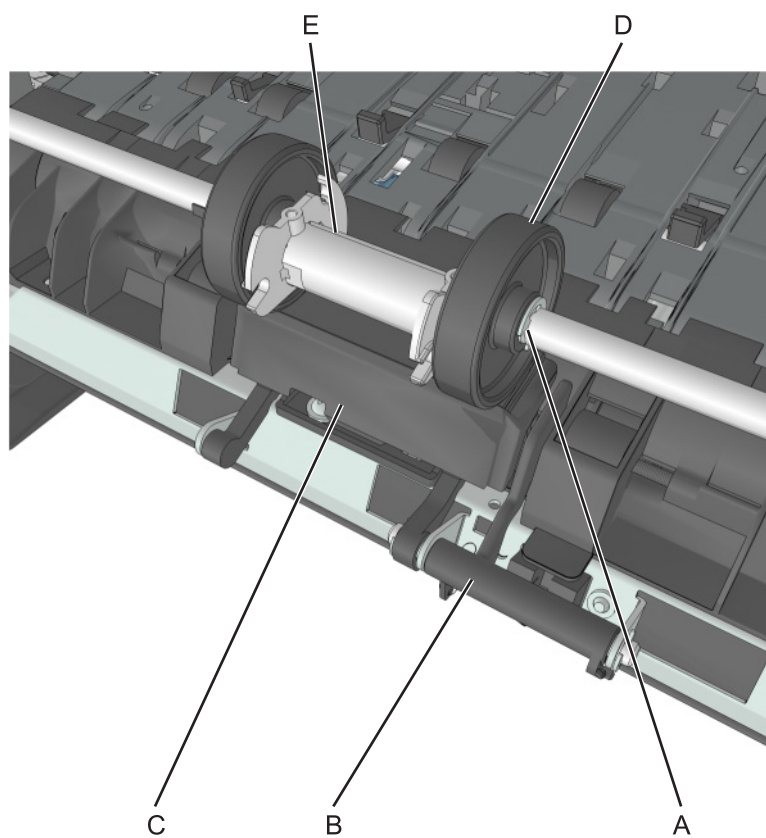

- 8** Remove the pin (F).

- 9** While pressing down the MPF sensor flag and separator pad, move the restraint roller (G) to the right.

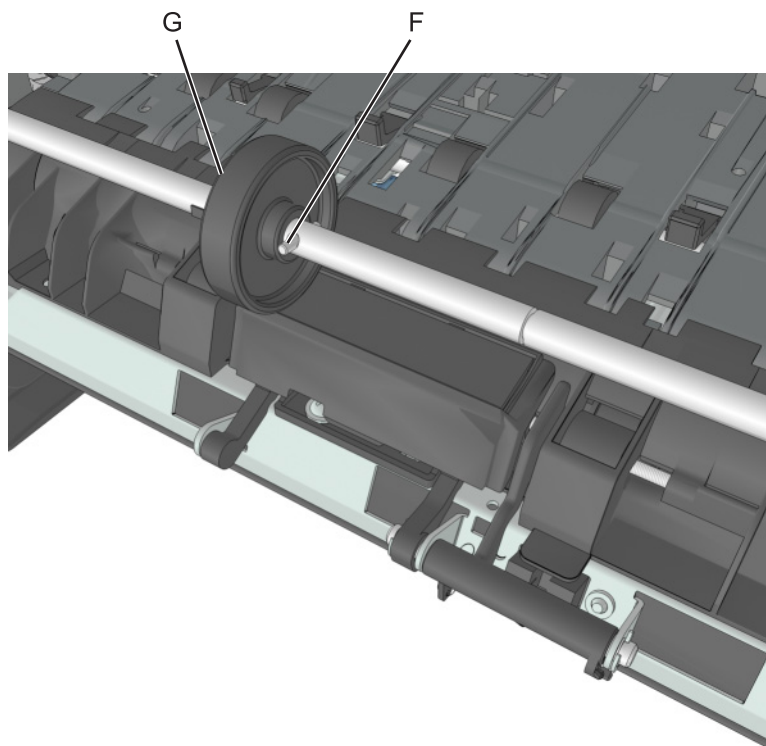

- 10** Remove the E-clip (H), and then move the shaft (I) to the right.

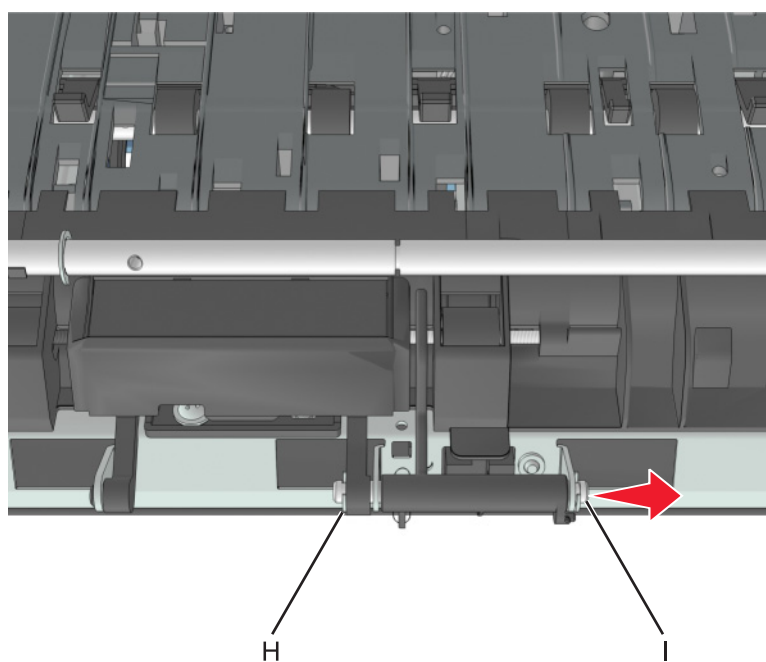

- 11** Remove the separator pad and the spring underneath.

Bottom side removals

Power supply removal

- 1 Remove the left cover. See [“Left cover removal” on page 302](#).
- 2 Remove the rear door and cover. See [“Rear exit door removal” on page 381](#) and [“Rear cover removal” on page 382](#).
- 3 Disconnect the fuser cable from the power supply, and disconnect the transfer roll cable from the left side of the printer.
- 4 Position the printer so that it sits on its right side.
- 5 Remove the five metal screws (A) and the plastic screw (B) securing the power supply.

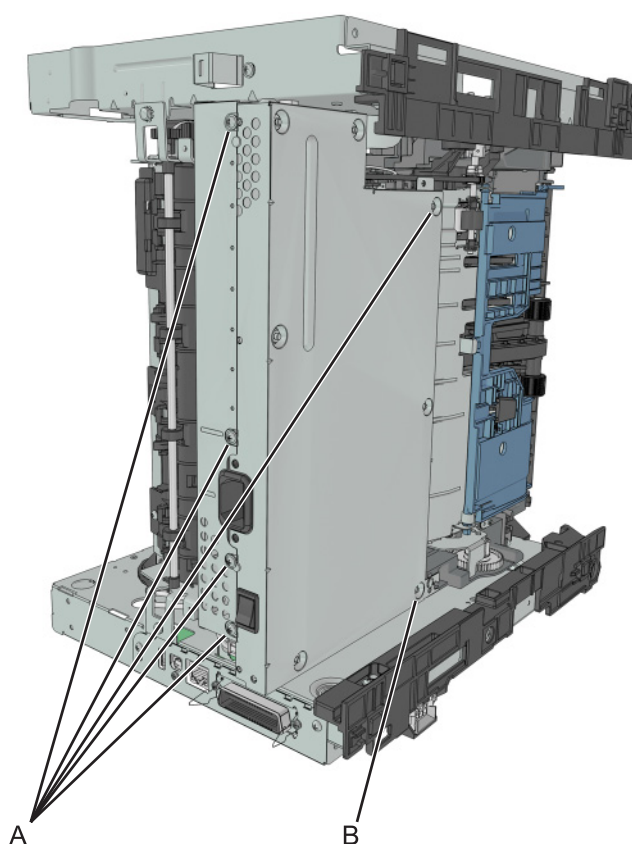

- 6 Remove the power supply, and then disconnect the cable from the power supply.

Power supply shield removal

- 1 Remove the left cover. See [“Left cover removal” on page 302](#).
- 2 Remove the rear door and cover. See [“Rear exit door removal” on page 381](#) and [“Rear cover removal” on page 382](#).
- 3 Remove the power supply. See [“Power supply removal” on page 361](#).
- 4 Position the printer so that it sits on its right side.

- 5 Remove the three screws (A), and then remove the power supply shield.

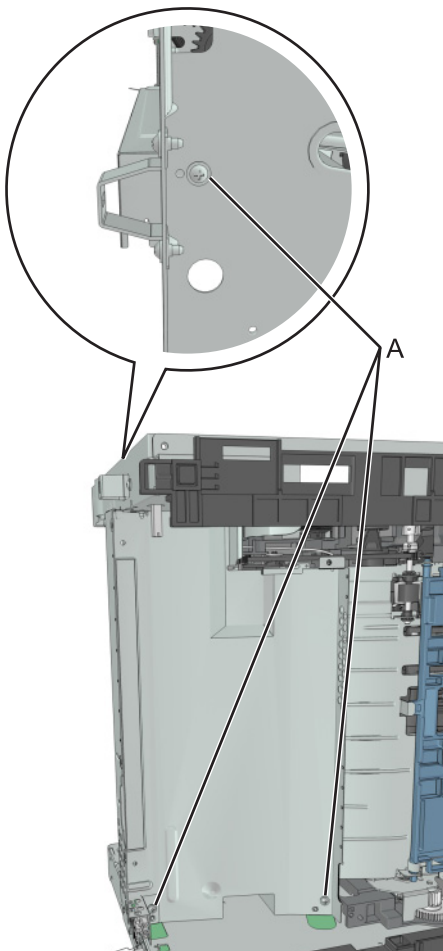

Duplex removal

- 1 Remove the left cover. See [“Left cover removal” on page 302.](#)
- 2 Remove the rear door and cover. See [“Rear exit door removal” on page 381](#) and [“Rear cover removal” on page 382.](#)
- 3 Remove the power supply. See [“Power supply removal” on page 361.](#)
- 4 Remove the power supply shield. See [“Power supply shield removal” on page 361.](#)
- 5 Position the printer so that it sits on its right side.

- 6 Remove the four screws (A) securing the duplex.

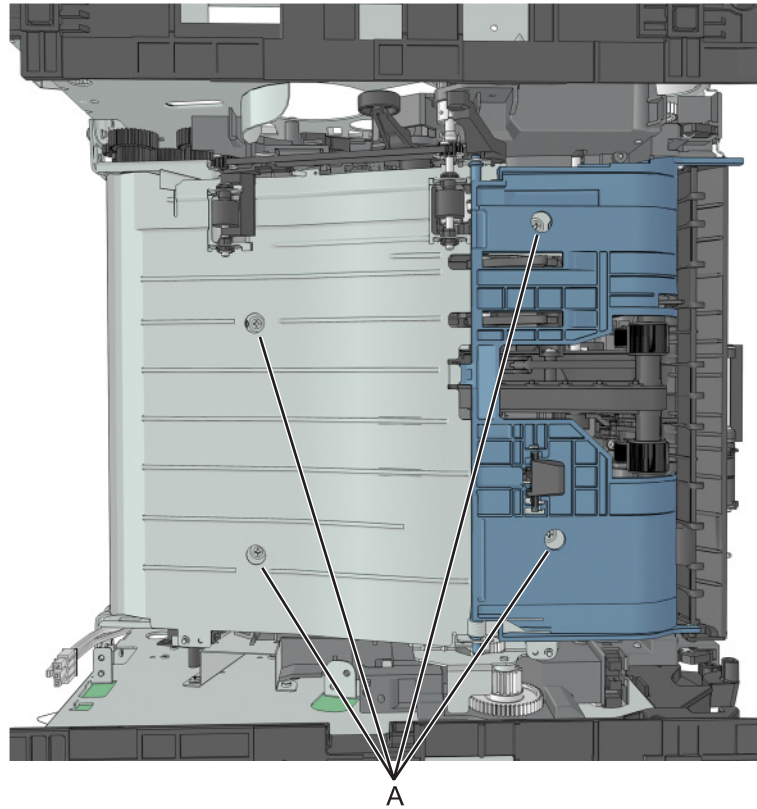

Note: The duplex link (B) is part of the FRU.

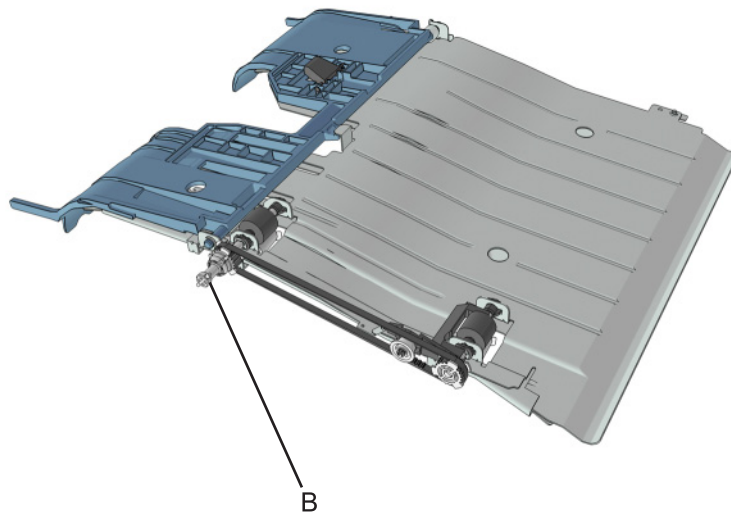

Duplex sensor and input sensor removal

- 1 Remove the left cover. See [“Left cover removal” on page 302](#).
- 2 Remove the right cover. See [“Right cover removal” on page 315](#).

- 3 Remove the rear door and cover. See [“Rear exit door removal” on page 381](#) and [“Rear cover removal” on page 382](#).
- 4 Remove the power supply. See [“Power supply removal” on page 361](#).
- 5 Remove the power supply shield. See [“Power supply shield removal” on page 361](#).
- 6 Remove the duplex. See [“Duplex removal” on page 362](#).
- 7 Disconnect the cable JDUPPI1 from the controller board.
- 8 Remove the two screws (A), and cut the cable near the frame to detach the sensors.

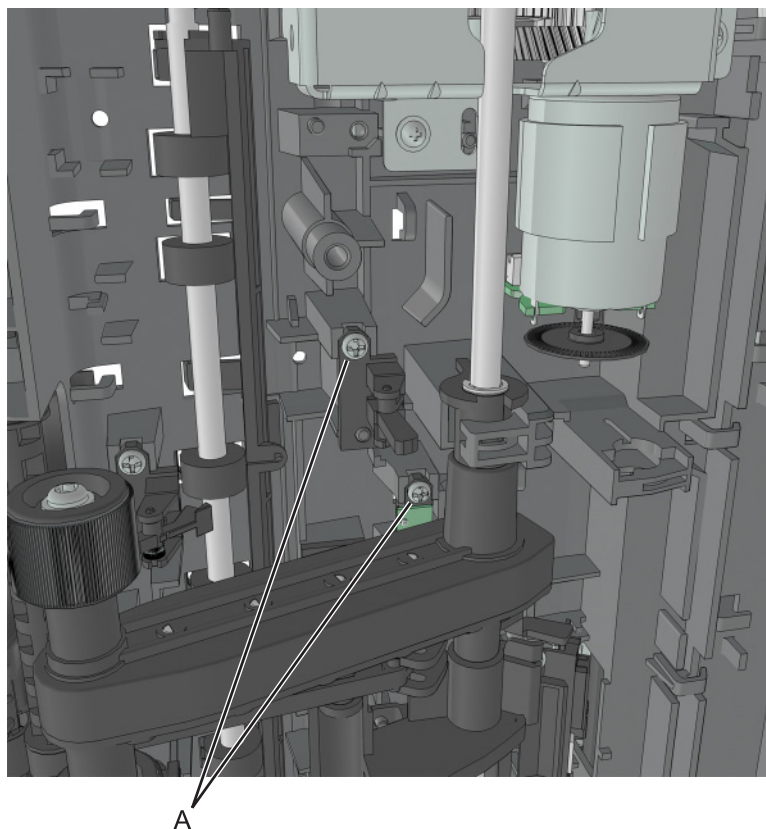

- 9 Remove the other half of the cable from the printer.

Installation notes:

- a Install the duplex sensor, followed by the input sensor.
- b Route the cable using the new path.

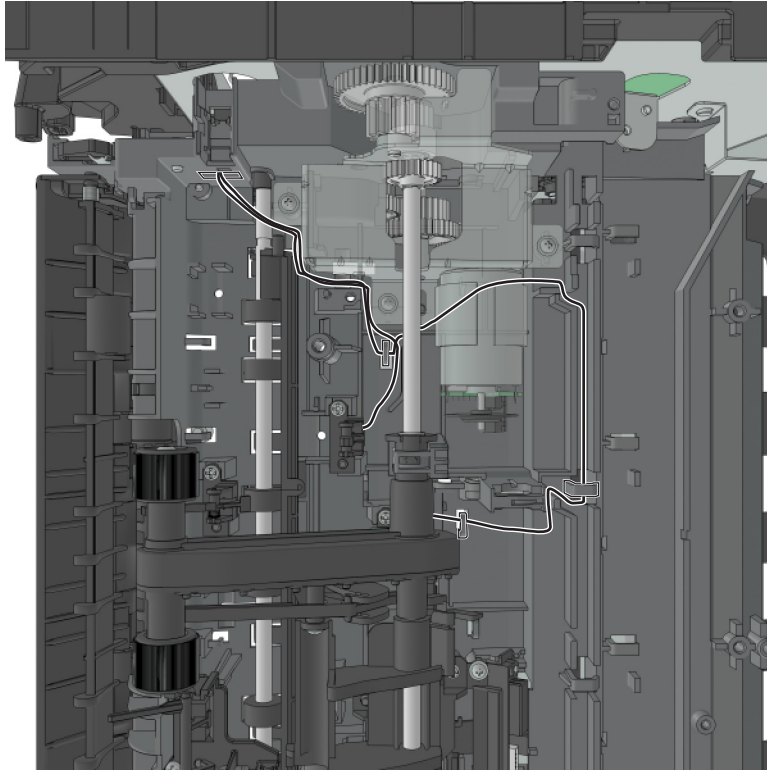

- c Secure the cable near the lift plate gearbox using cable ties. Cut off any excess cable tie.

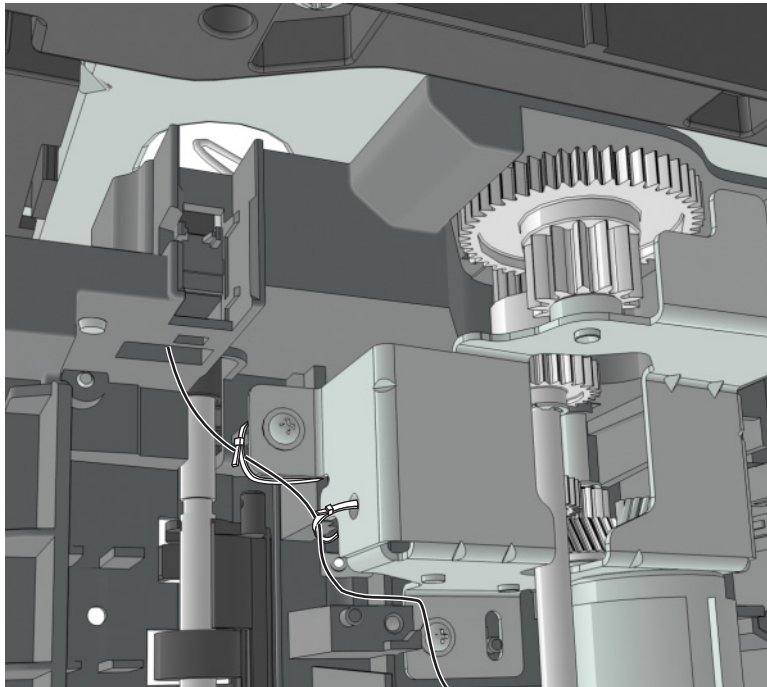

Parts removal

Index sensor removal

- 1 Remove the left cover. See [“Left cover removal” on page 302](#).
- 2 Remove the right cover. See [“Right cover removal” on page 315](#).
- 3 Remove the rear door and cover. See [“Rear exit door removal” on page 381](#) and [“Rear cover removal” on page 382](#).
- 4 Remove the power supply. See [“Power supply removal” on page 361](#).
- 5 Remove the power supply shield. See [“Power supply shield removal” on page 361](#).
- 6 Remove the duplex. See [“Duplex removal” on page 362](#).
- 7 Disconnect the cable JINDEX1 from the controller board.
- 8 Remove the screw (A).
- 9 Route off the cable, and then remove the index sensor.

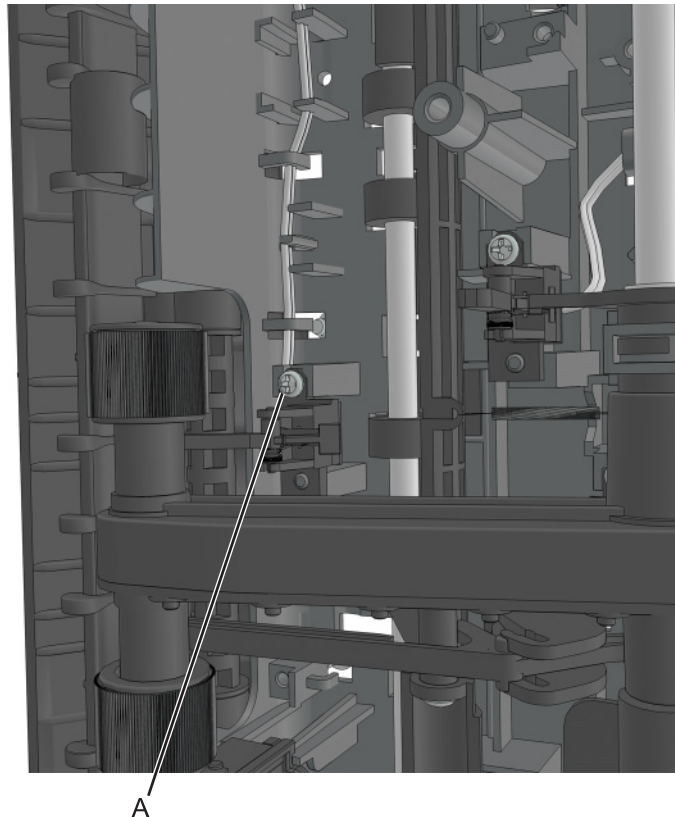

Media present sensor removal

- 1 Remove the left cover. See [“Left cover removal” on page 302](#).
- 2 Remove the rear door and cover. See [“Rear exit door removal” on page 381](#) and [“Rear cover removal” on page 382](#).
- 3 Remove the power supply. See [“Power supply removal” on page 361](#).
- 4 Remove the power supply shield. See [“Power supply shield removal” on page 361](#).

- 5 Remove the duplex. See [“Duplex removal” on page 362](#).
- 6 Position the printer so that it sits on its left side.
- 7 Disconnect the cable from the media present sensor (A).

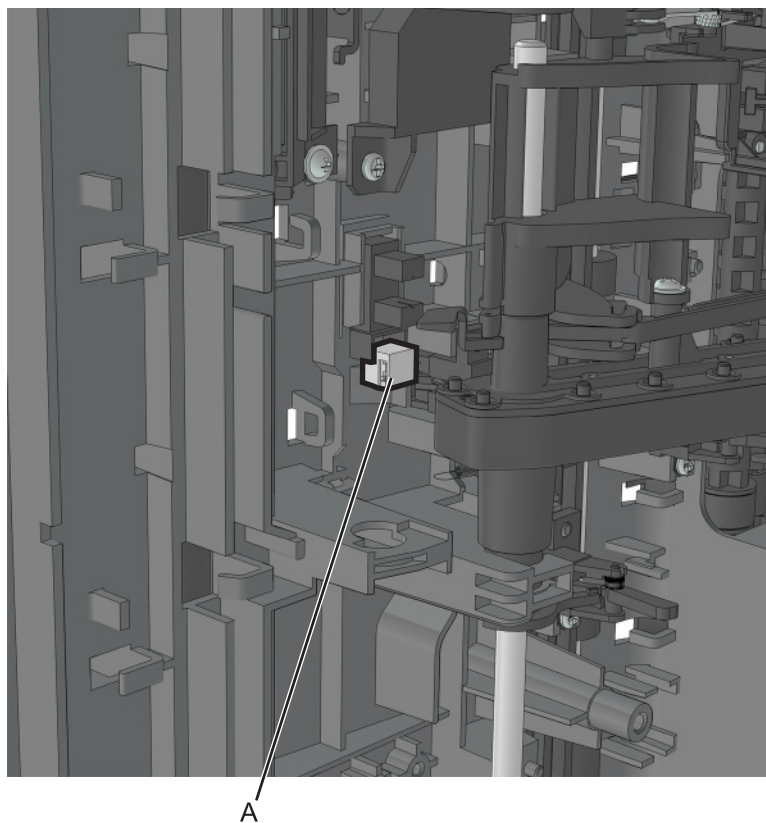

- 8 From inside the printer, release the three latches (B).

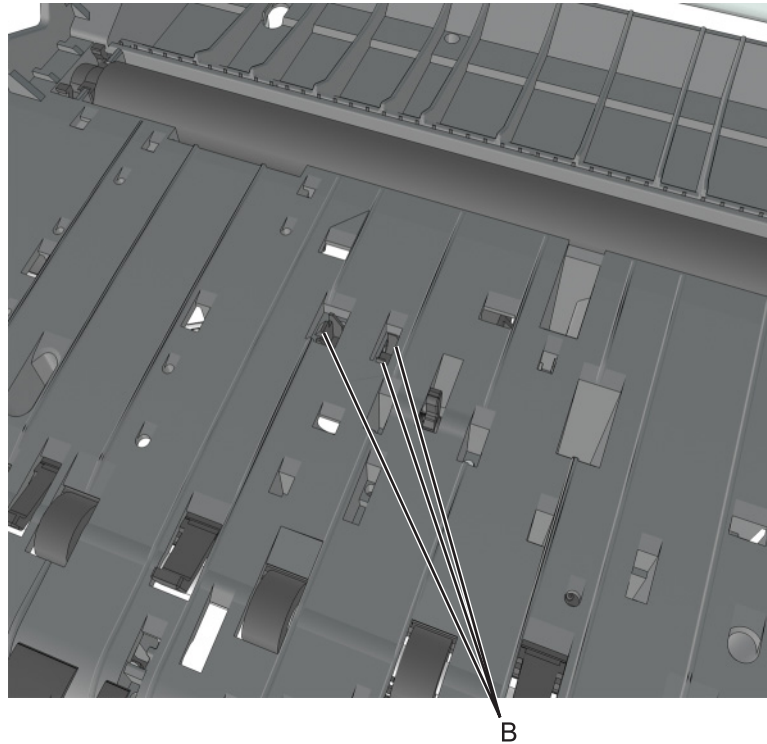

Trailing edge sensor removal

- 1 Remove the left cover. See [“Left cover removal” on page 302.](#)
- 2 Remove the right cover. See [“Right cover removal” on page 315.](#)
- 3 Remove the rear door and cover. See [“Rear exit door removal” on page 381](#) and [“Rear cover removal” on page 382.](#)
- 4 Remove the power supply. See [“Power supply removal” on page 361.](#)
- 5 Remove the power supply shield. See [“Power supply shield removal” on page 361.](#)
- 6 Remove the duplex. See [“Duplex removal” on page 362.](#)
- 7 Position the printer so that it sits on its left side.
- 8 Disconnect the cable JACM1 from the controller board.
- 9 Release the retainer spring (A) from the bracket (B).

- 10 Remove the screw (C).

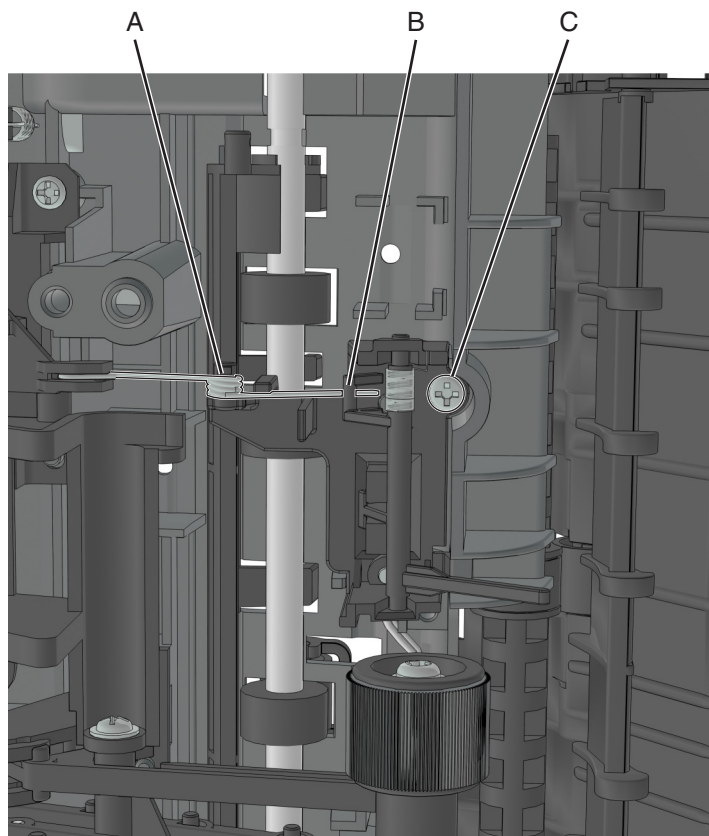

ACM assembly removal

- 1 Remove the left cover. See [“Left cover removal” on page 302.](#)
- 2 Remove the rear door and cover. See [“Rear exit door removal” on page 381](#) and [“Rear cover removal” on page 382.](#)
- 3 Remove the power supply. See [“Power supply removal” on page 361.](#)
- 4 Remove the power supply shield. See [“Power supply shield removal” on page 361.](#)
- 5 Remove the duplex. See [“Duplex removal” on page 362.](#)
- 6 Remove the media present sensor flag. See [“Sensor \(toner density\) and media present sensor flag removal” on page 374.](#)

- 7** Remove the E-clip (A), and slide the washer (B) from the shaft.

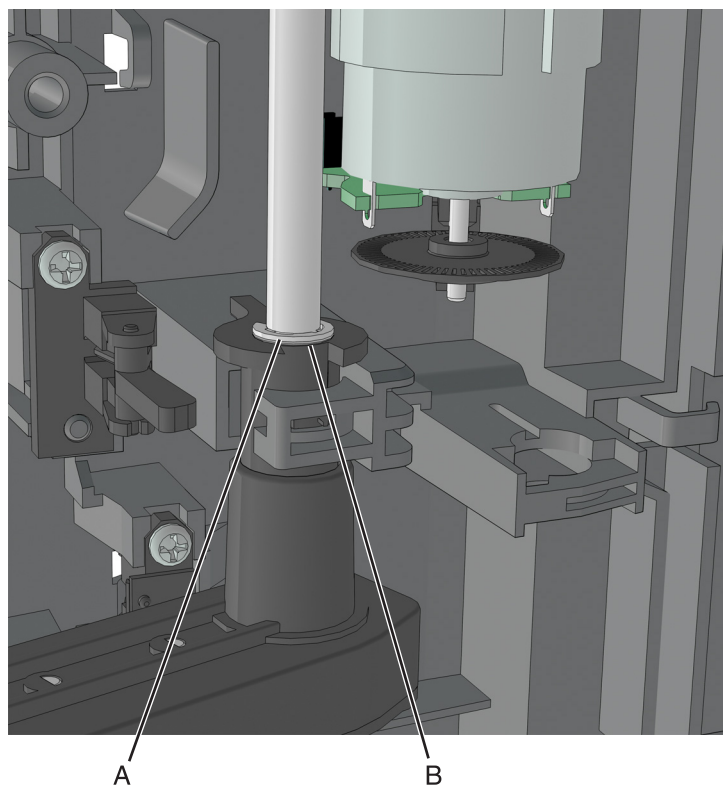

- 8** Release the lock by sliding the bushing and then rotating it clockwise.

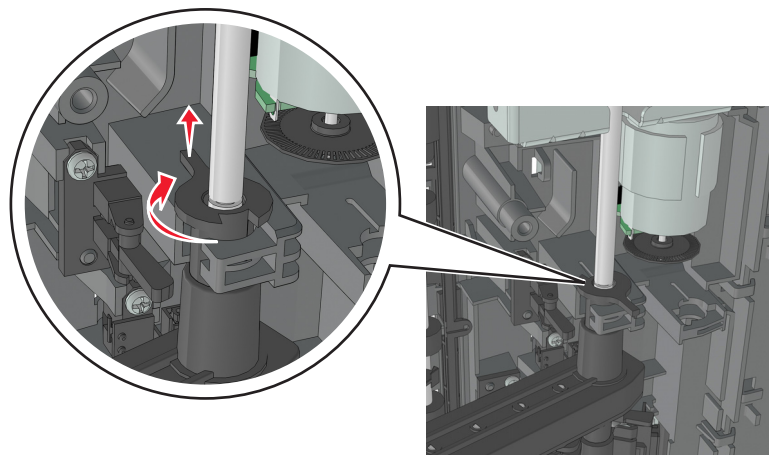

- 9** Remove the ACM assembly along with its shaft.

Below is the ACM assembly.

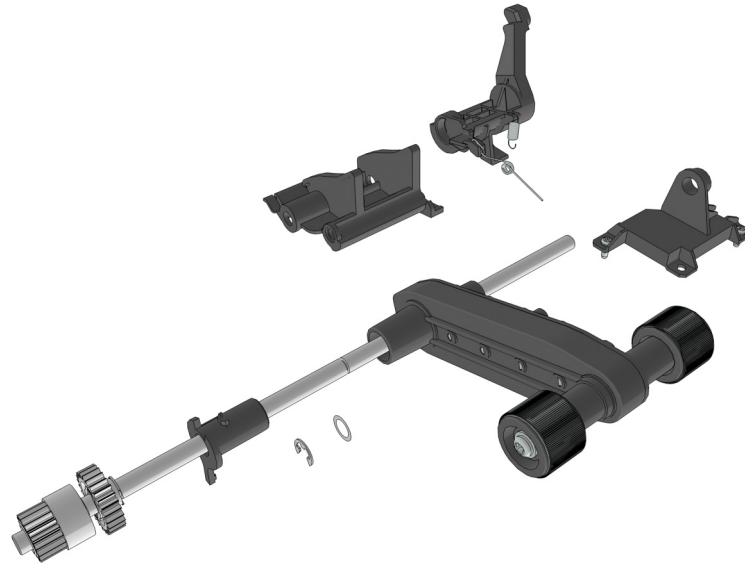

Pick/lift motor gearbox removal

- 1 Remove the left cover. See [“Left cover removal” on page 302.](#)
- 2 Remove the rear door and cover. See [“Rear exit door removal” on page 381](#) and [“Rear cover removal” on page 382.](#)
- 3 Remove the power supply. See [“Power supply removal” on page 361.](#)
- 4 Remove the power supply shield. See [“Power supply shield removal” on page 361.](#)
- 5 Remove the duplex. See [“Duplex removal” on page 362.](#)
- 6 Remove the ACM assembly. See [“ACM assembly removal” on page 369.](#)
- 7 Position the printer so that it sits on its left side.

- 8 Remove the three screws (A).

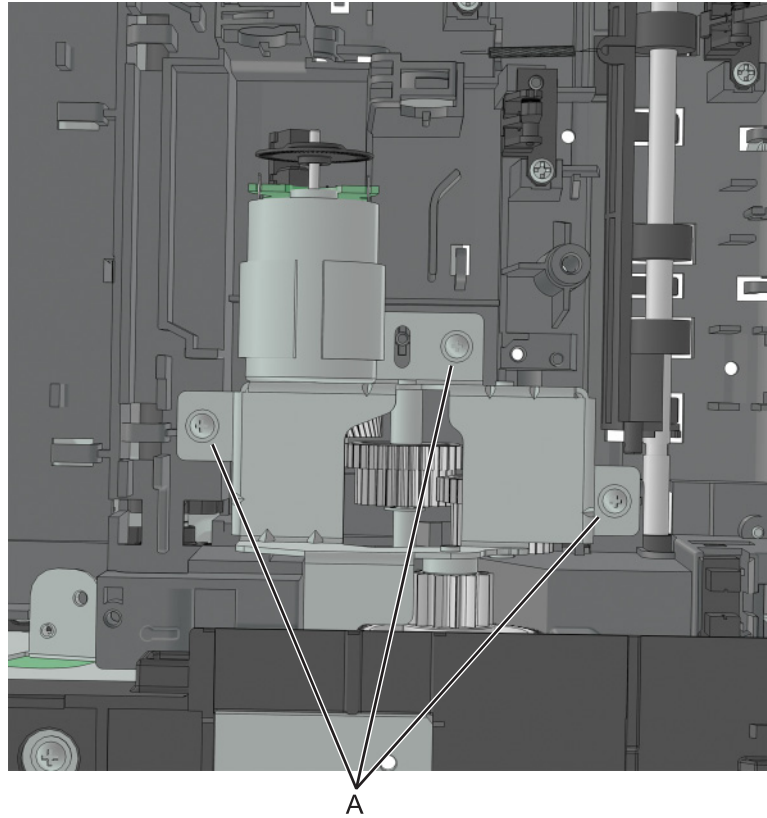

- 9 Disconnect the cable from the pick/lift motor gearbox.

Tray guide removal

Left guide

Installation note: Before removing the guide, note the position of the ground spring. It will need to be re-installed when the guide is re-installed.



- 1 Remove the rear cover. See [“Rear cover removal” on page 382.](#)
- 2 Remove the left cover. See [“Left cover removal” on page 302.](#)

- 3 Turn the printer on its side (left side down), then remove the three screws (A) from the left guide.

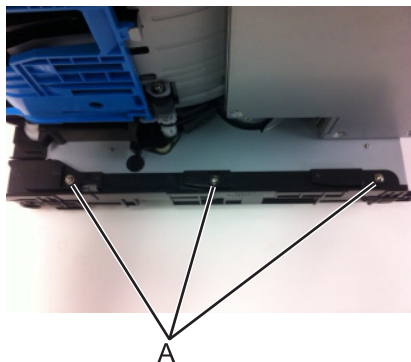

- 4 Remove the left guide.

Installation note: When re-installing the guide, insert the spring as shown.



Right guide

- 1 Remove the rear cover. See [“Rear cover removal” on page 382](#).
- 2 Remove the right cover. See [“Right cover removal” on page 315](#).
- 3 Remove the controller board shield. See [“Controller board shield removal” on page 322](#).
- 4 Disconnect the option cable (JOPT1) from the controller board.
- 5 Turn the printer on its side (right side down), then remove the three screws (B) from the right guide.

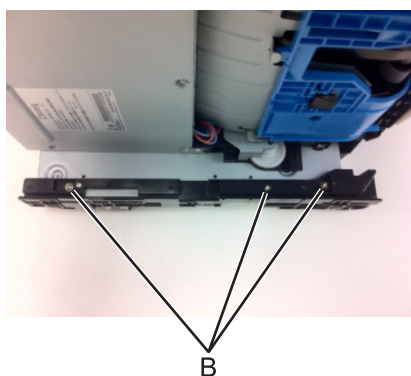

- 6 Remove the guide from the frame.

- 7 Squeeze the latches to release the connector, then push the connector off the guide.

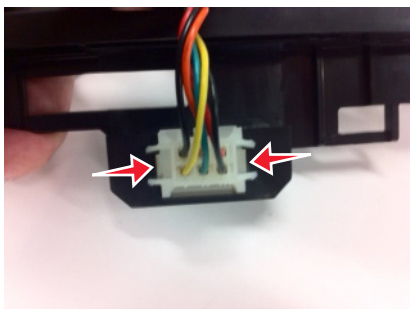

Sensor (toner density) and media present sensor flag removal

Note: For a video demonstration, see [Sensor \(toner density\) and media present sensor flag removal](#).

- 1 Remove the toner cartridge, and then remove the imaging unit.
- 2 Remove the tray insert.
- 3 Remove the rear door and cover. See [“Rear cover removal” on page 382](#).
- 4 Remove the power supply. See [“Power supply removal” on page 361](#).
- 5 Remove the duplex. See [“Duplex removal” on page 362](#).
- 6 Remove the screws (A).

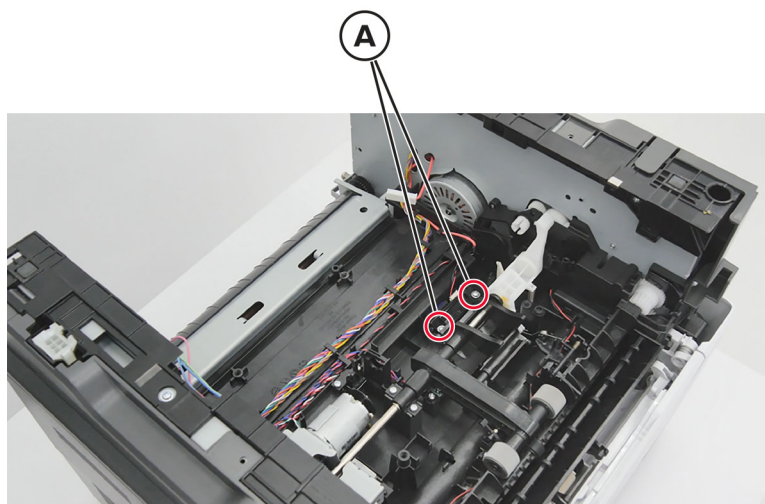

- 7 Remove the sensor (B), and then remove the wiper (C).

8 Disconnect the connector (D).

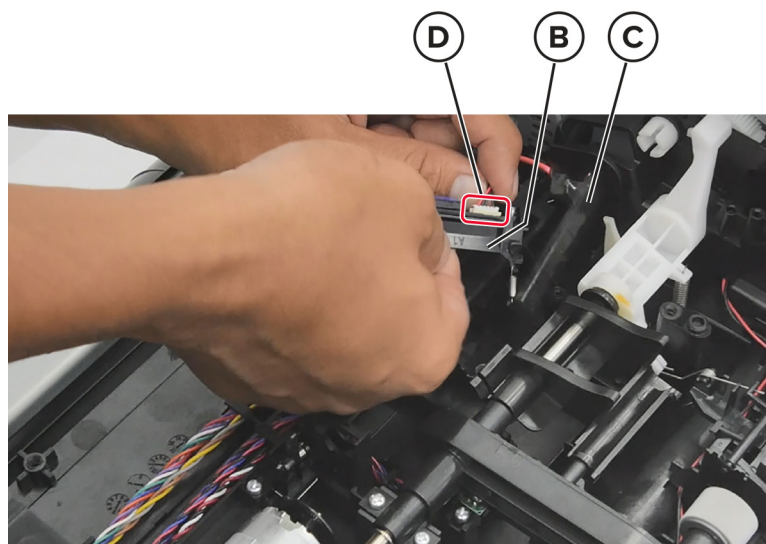

9 Remove the screw (E).

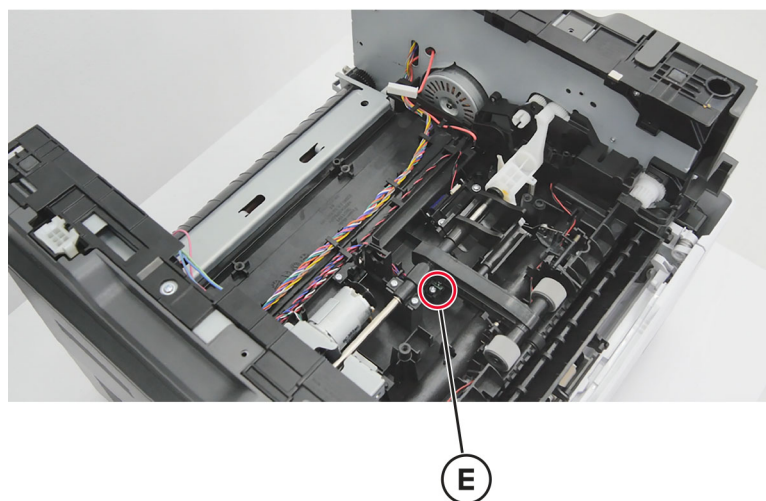

- 10 Lift the pick roller assembly and then remove the sensor flag and bracket (F).

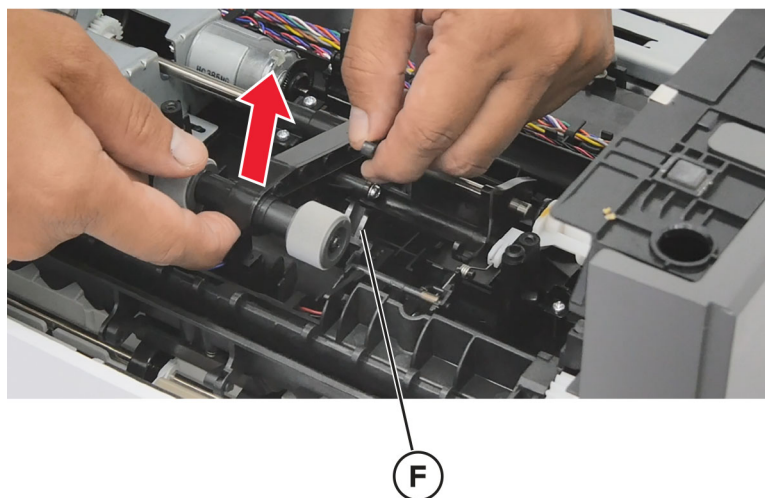

Installation note: Refer to the following procedures when installing the toner density sensor and media present sensor flag:

- 1 Pull down the actuator, and then place the wiper (G) in position.

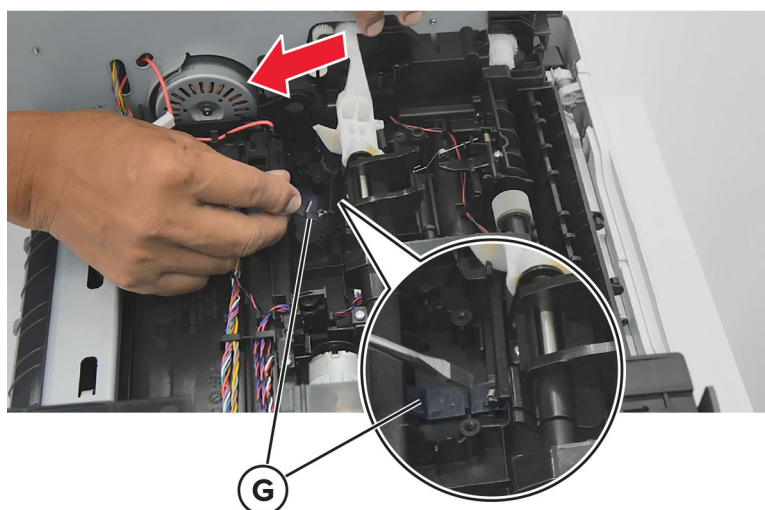

2 Attach the sensor bracket (H) and the spring (I).

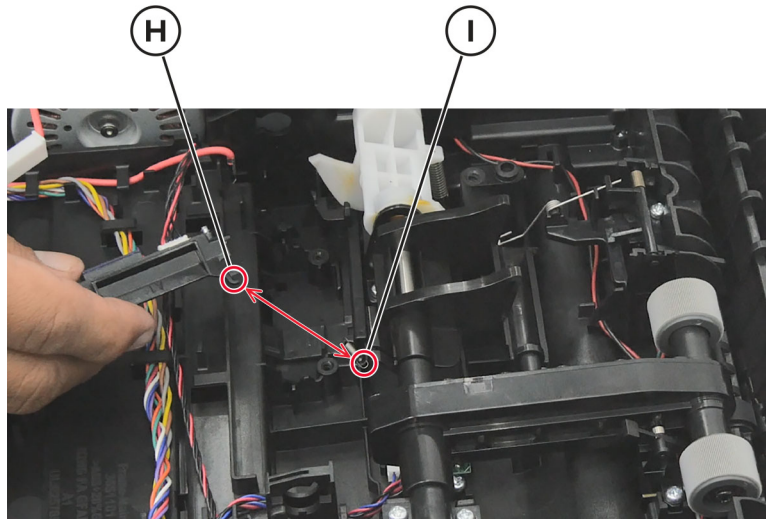

3 Connect the connector (J) to the sensor, and then route the cable on the harness (K).

Note: Before securing the sensor bracket using screws, do the following:

a Lift the actuator.

b If the wiper goes along with the actuator, then the sensor bracket is properly engaged with the wiper.

4 Secure the sensor bracket using screws (L).

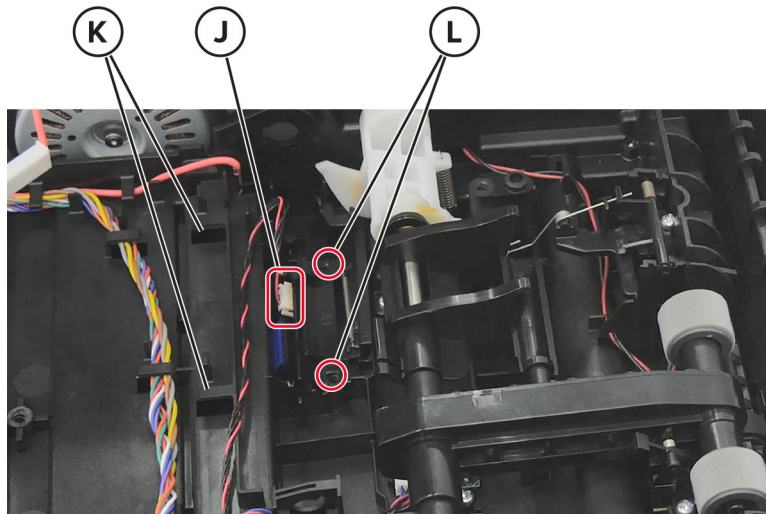

Note: After securing the sensor bracket using screws, do the following:

- a** Apply RheoGel 793 to the top and bottom of the shutter blade extension.

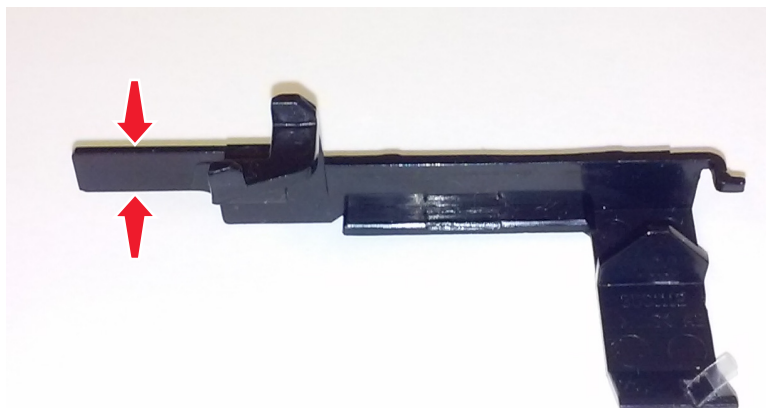

- b** Apply RheoGel 793 to the point of contact between the bracket (A) and cam.
c Apply RheoGel 793 to the point of contact to the lower edge (B) where the wiper bracket glides.

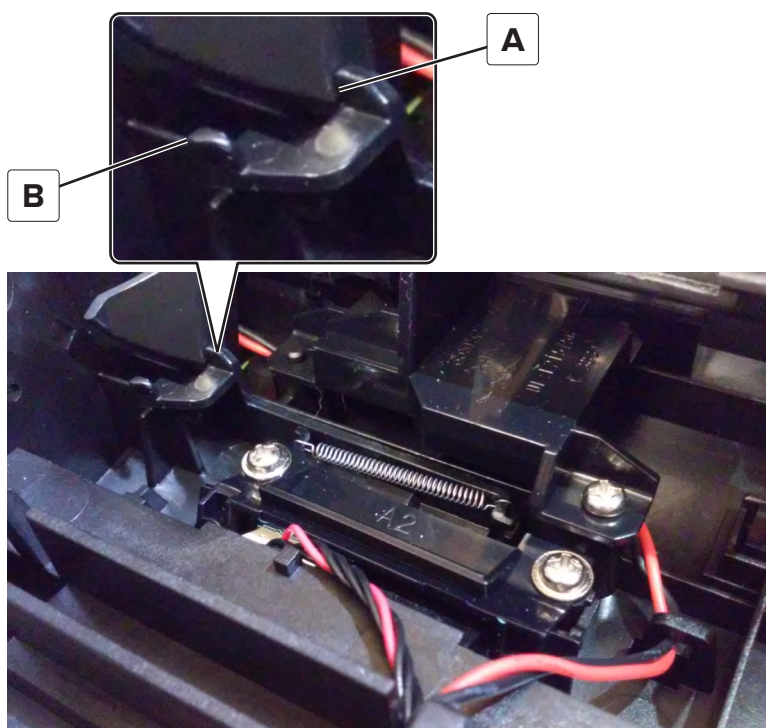

- 5 Lift the pick roller assembly, and then place the bracket (M) in position.

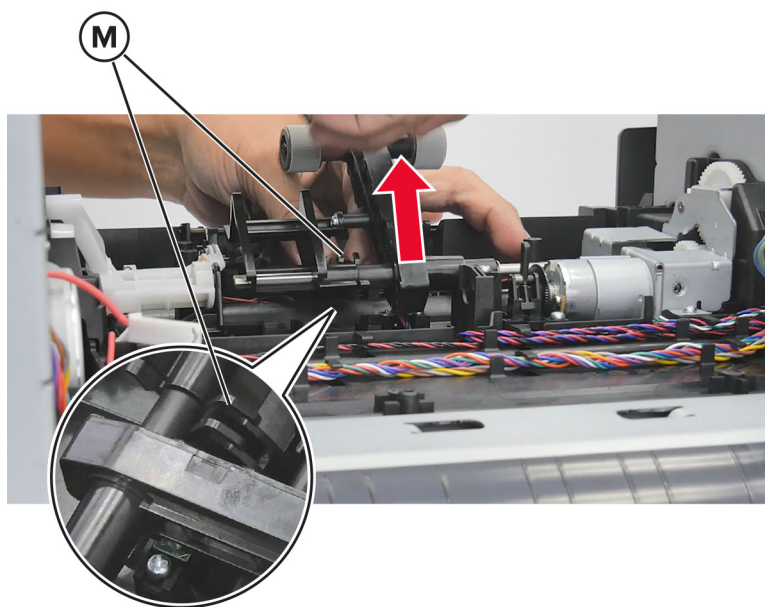

- 6 Secure the bracket in place using screws (N).

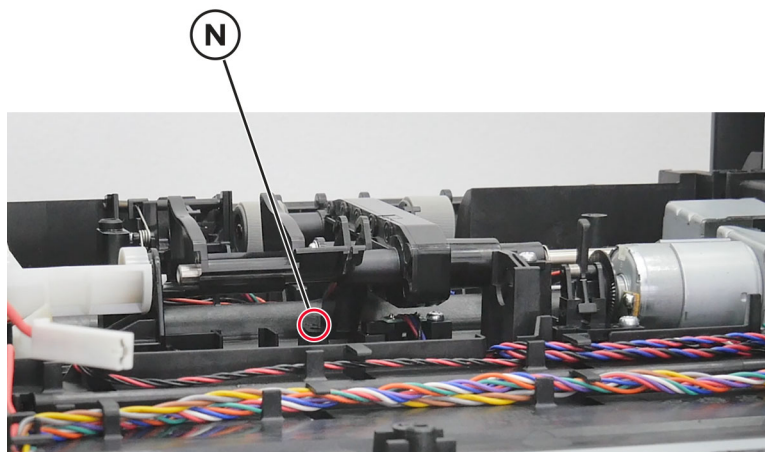

7 Install the sensor flag (O) into the bracket.

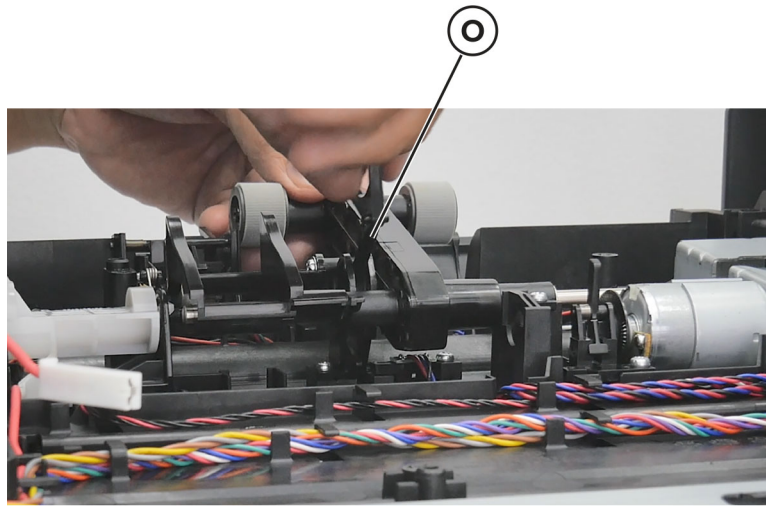

Note: To check if the sensor flag is properly installed, do the following:

- a Lift the pick roller assembly.
- b If the sensor flag goes along with the pick roller assembly when lifted, then the sensor flag is properly installed.

Rear side removals

Dust cover removal

- 1 Press the latches on each side of the dust cover.
- 2 Remove the dust cover.

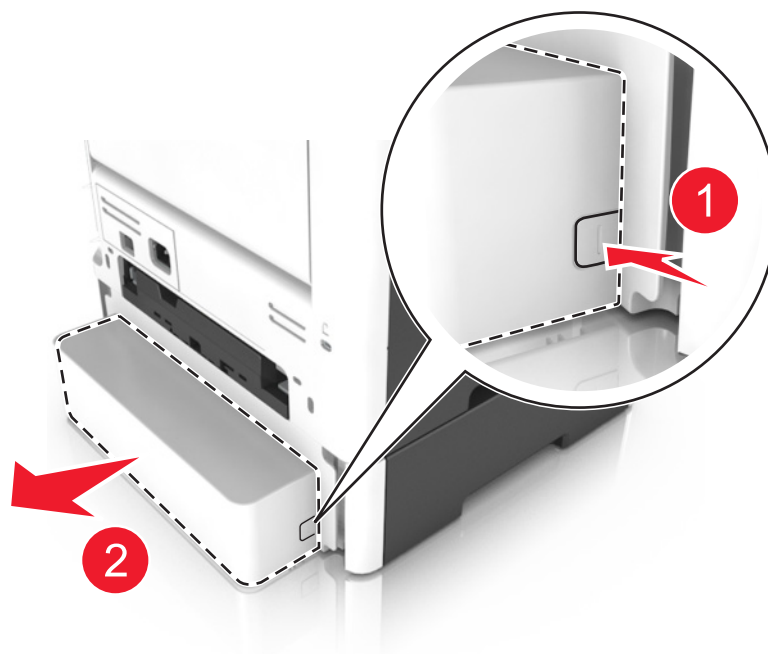

Rear exit door removal

- 1 Open the rear door as shown below.



- 2 Pull the exit door upward to release the hinges, and remove.



Rear cover removal

- 1 Open the rear exit door.
- 2 Remove the two screws (A) securing the rear cover.

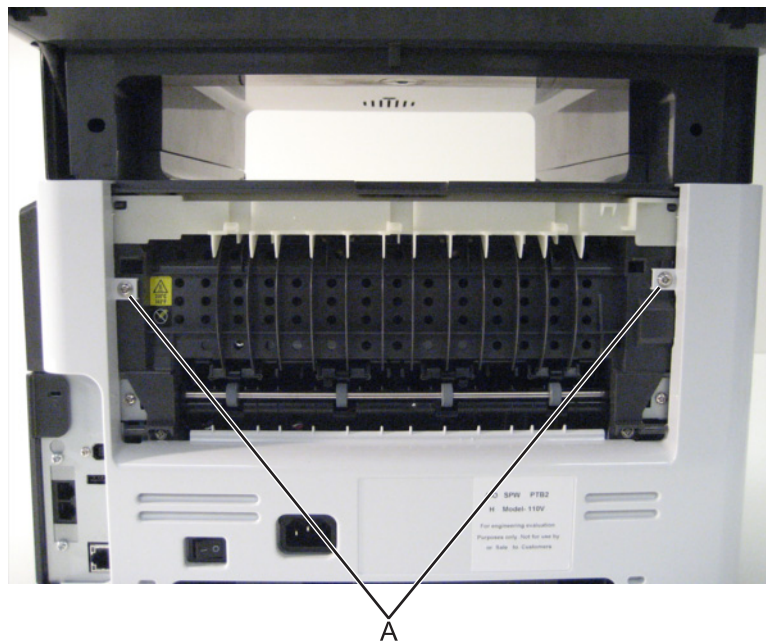

Parts removal

- 3 Lift the upper portion of the machine to release the cover, and then remove the cover.



Redrive assembly removal

- 1 Remove the right cover. See [“Right cover removal” on page 315.](#)
- 2 Remove the left cover. See [“Left cover removal” on page 302.](#)
- 3 Remove the rear door and cover. See [“Rear exit door removal” on page 381](#) and [“Rear cover removal” on page 382.](#)
- 4 Disconnect cable JNRW1 from the controller board.
- 5 Remove the two screws (A), and then disconnect the reverse solenoid.

Note: Do not disconnect the reverse solenoid cable from the controller board.

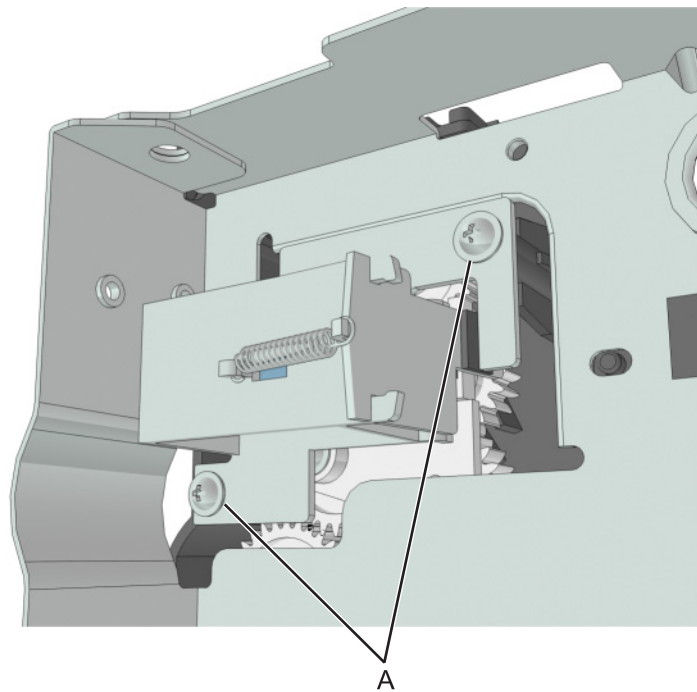

- 6 Remove the stapler cable. See [“Stapler cable removal” on page 387.](#)
- 7 Remove the six screws (B) securing the redrive assembly.

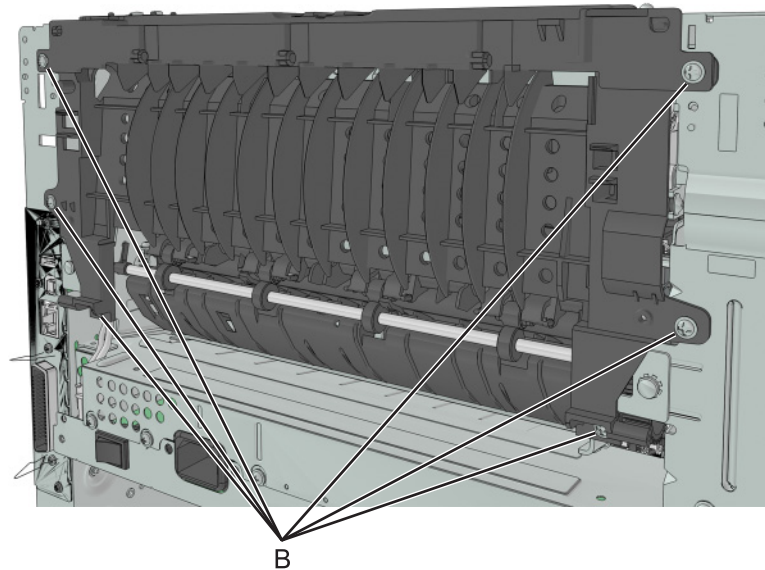

Redrive shaft removal

- 1 Remove the right cover. See [“Right cover removal” on page 315.](#)
- 2 Remove the left cover. See [“Left cover removal” on page 302.](#)
- 3 Remove the rear door and cover. See [“Rear exit door removal” on page 381](#) and [“Rear cover removal” on page 382.](#)

- 4 Remove the top cover. See [“Top cover removal” on page 391.](#)
- 5 Remove the redrive assembly. See [“Redrive assembly removal” on page 383.](#)
- 6 Remove the two screws (A), and then remove the top of the redrive assembly.

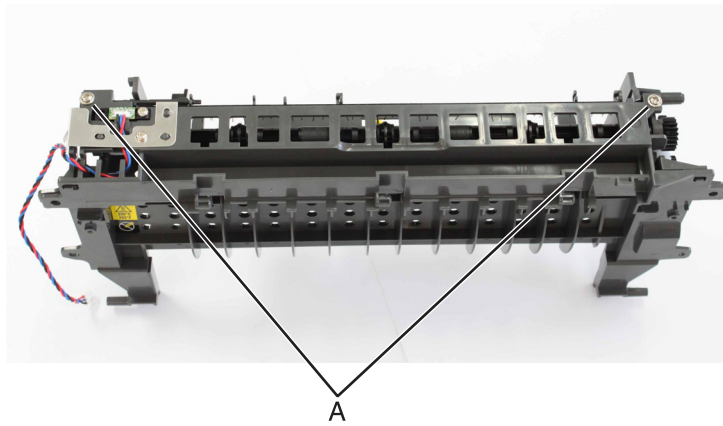

- 7 Remove the shaft.



- 8 If necessary, remove the bushing (B) from the redrive assembly.



Installation note: Install the bushing (A) on the redrive assembly before installing the shaft.

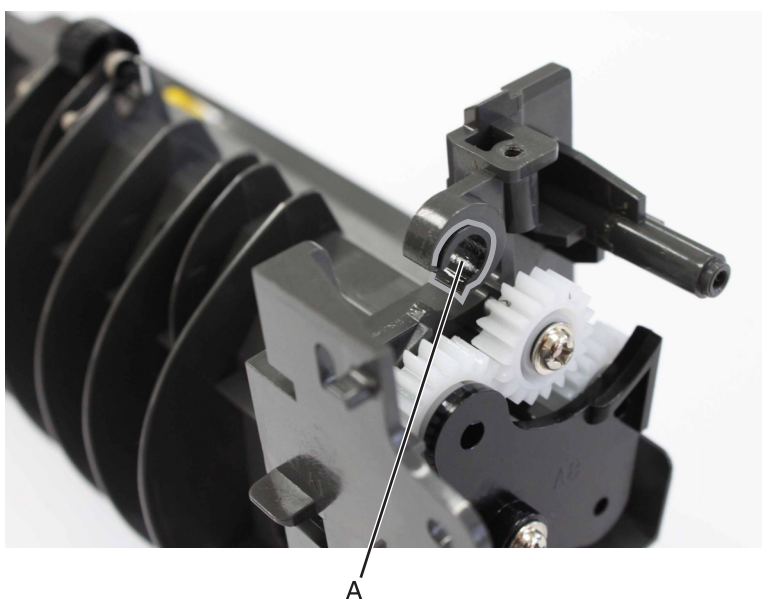

Fuser removal

- 1 Remove the left cover. See [“Left cover removal” on page 302](#).
- 2 Remove the rear door and cover. See [“Rear exit door removal” on page 381](#) and [“Rear cover removal” on page 382](#).
- 3 Remove the redrive assembly. See [“Redrive assembly removal” on page 383](#).
- 4 Disconnect the cable JEXIT1 from the controller board.
- 5 Disconnect the two cables (A).

- 6 Remove the two screws (B) securing the fuser.

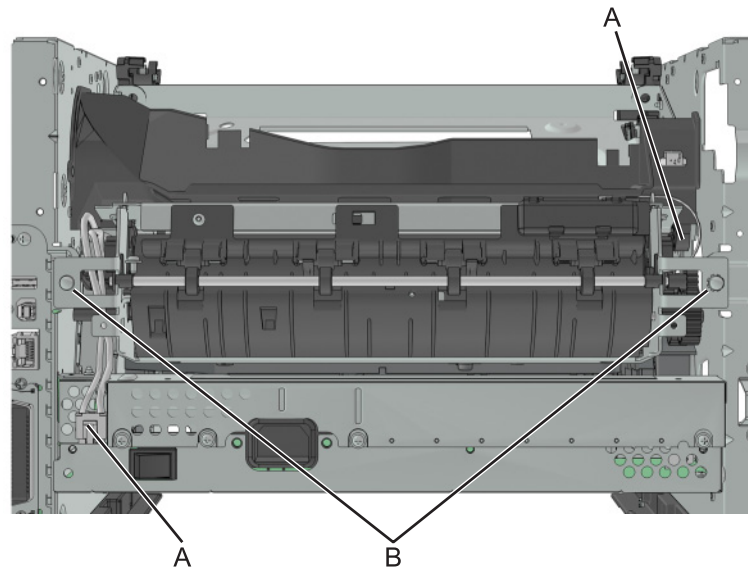

Note: For a video demonstration, see the *Fuser Remove and Install Video* at http://infoserve.lexmark.com/videos/MSX_fuser.html

Stapler cable removal

- 1 Remove the right cover. See [“Right cover removal” on page 315.](#)
- 2 Remove the rear cover. See [“Rear cover removal” on page 382.](#)
- 3 Remove the controller board shield. See [“Controller board shield removal” on page 322.](#)
- 4 Disconnect the stapler cable (J56) from the controller board.

- 5 Remove the three screws (A) from the mounting bracket.

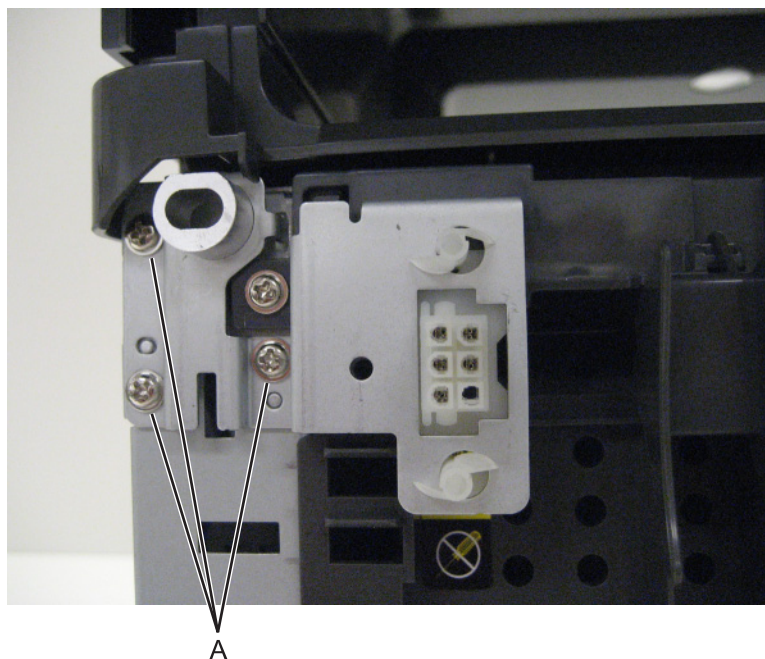

- 6 Remove the stapler cable and mounting bracket from the printer frame while feeding the cable through the redrive unit and printer frame.

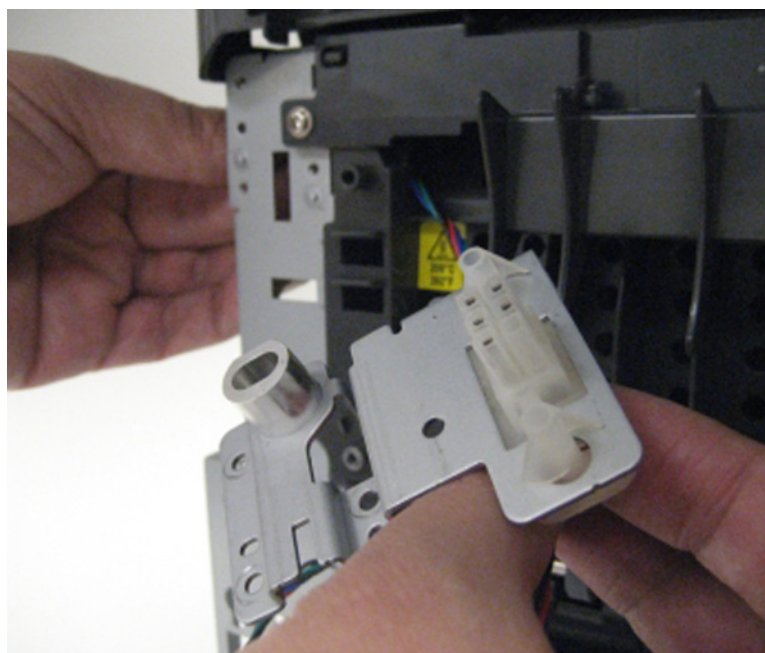

- 7 Using a pair of pliers, squeeze the nylon mounts to dislodge the stapler connector, and remove the stapler cable.

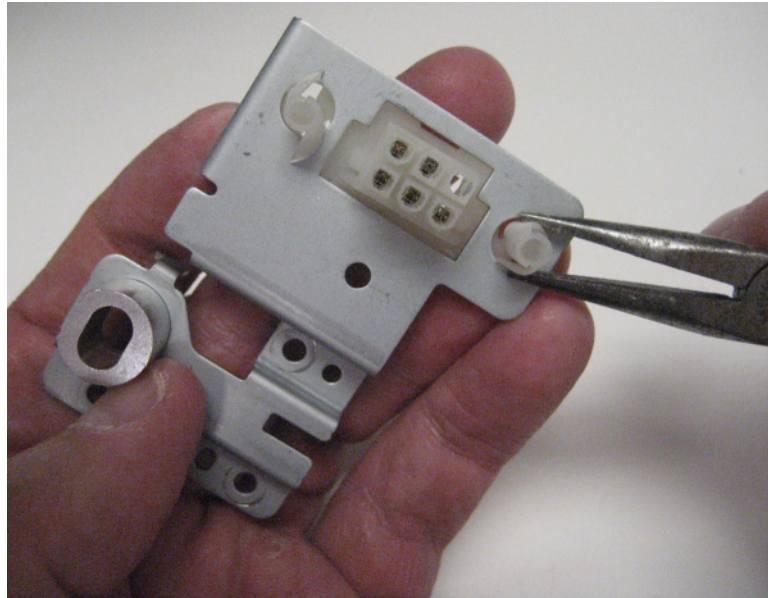

Diverter spring removal

- 1 Remove the rear cover. See [“Rear cover removal” on page 382.](#)
- 2 Using a spring hook, detach the diverter spring from the diverter and from the redrive.

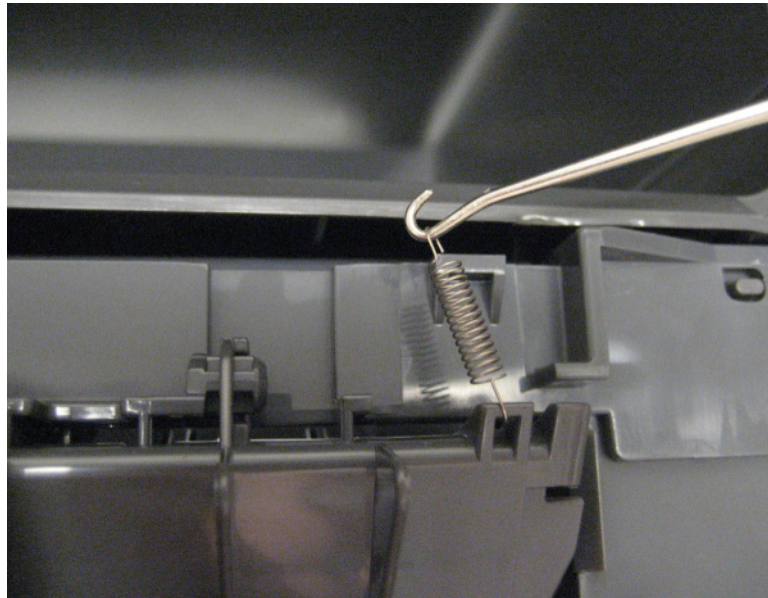

Diverter cover removal

- 1 Firmly grasp both sides of the diverter cover.
- 2 Pull the cover away from the scanner, and remove.



Top side removals

Top cover removal

- 1 Remove the scanner assembly. See [“Scanner assembly removal” on page 405.](#)
- 2 Remove the two screws from the top cover (A).

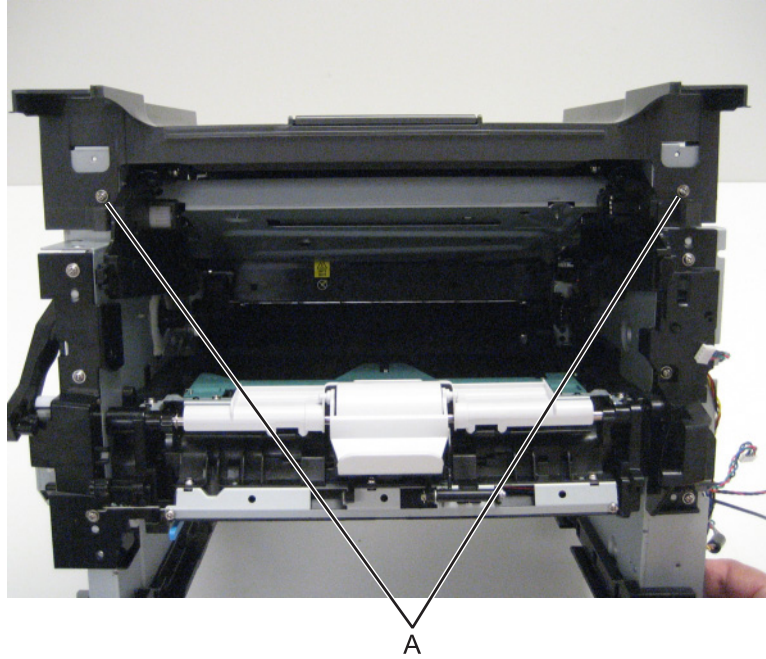

- 3 Remove the fan and fan duct.
- 4 Disconnect the bin full sensor cable (JBINS1) from the controller board.

- 5 Remove the top cover from the printer frame while feeding the bin full sensor cables through the side of the printer frame.

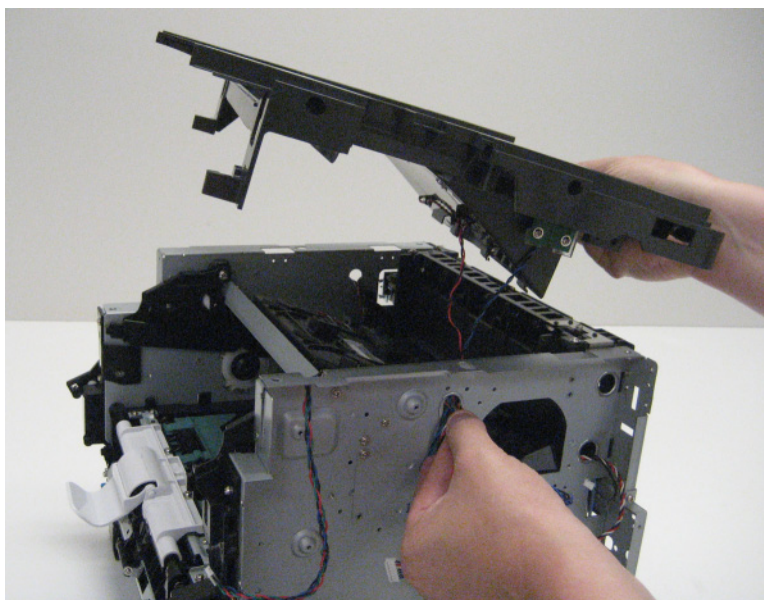

Bin full sensor/lens removal

Note: The lens is a separate FRU.

- 1 Remove the top cover. See [“Top cover removal” on page 391](#).
- 2 Remove the two screws (A) securing the right sensor and right lens to the top cover.

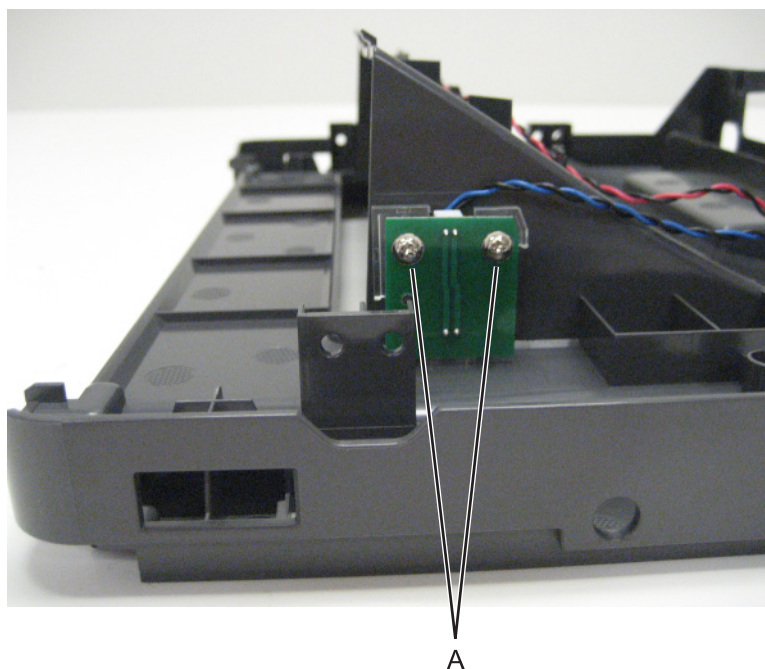

- 3** Disconnect the cable (J1) from the sensor.

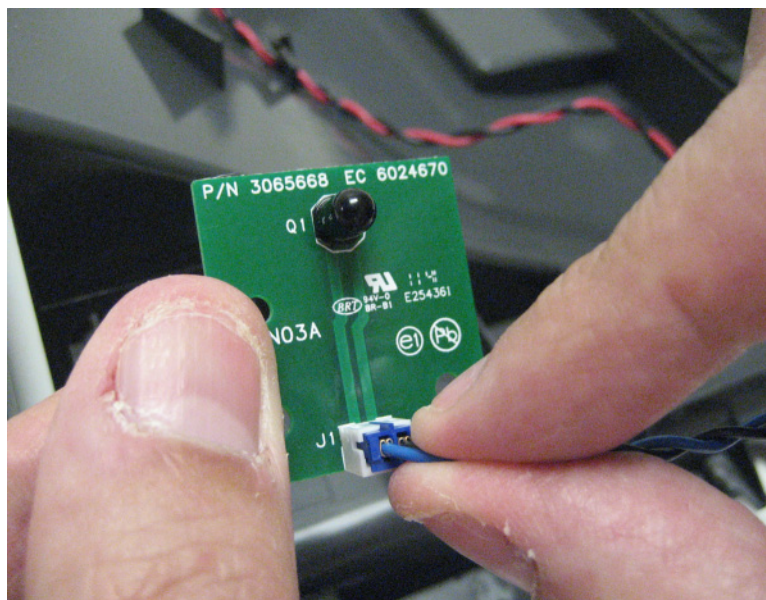

- 4** Remove the two screws (B) securing the left sensor and left lens to the top cover.

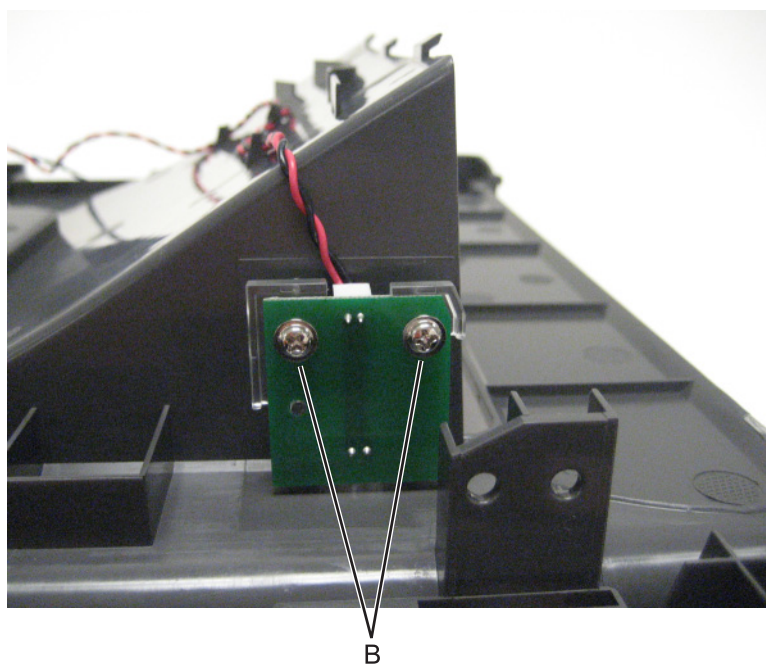

- 5 Disconnect the cable (J1RED1) from the sensor.

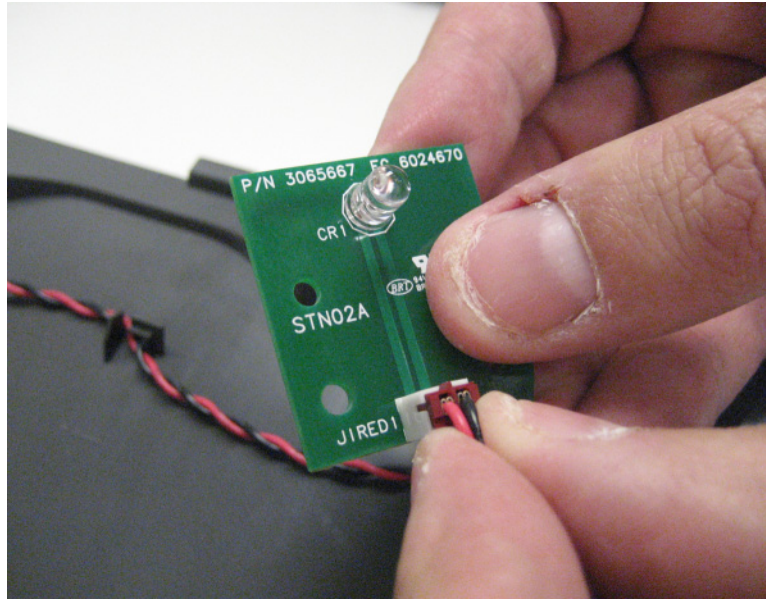

Installation note: When installing this FRU, update the firmware to RIP (LW20.SB7.P231) and Engine (FDN.PIR.E310) or higher.

Installation warning: This is a mandatory firmware update. Failure to update the firmware will cause the sensor to prematurely fail, requiring another sensor replacement. This update extends the life of the sensor.

Bin full sensor cable removal

- 1 Remove the top cover. See [“Top cover removal” on page 391](#).
- 2 Remove the bin full sensor. See [“Bin full sensor/lens removal” on page 392](#).

- 3 Release the cable from the cable holders (A), and remove.

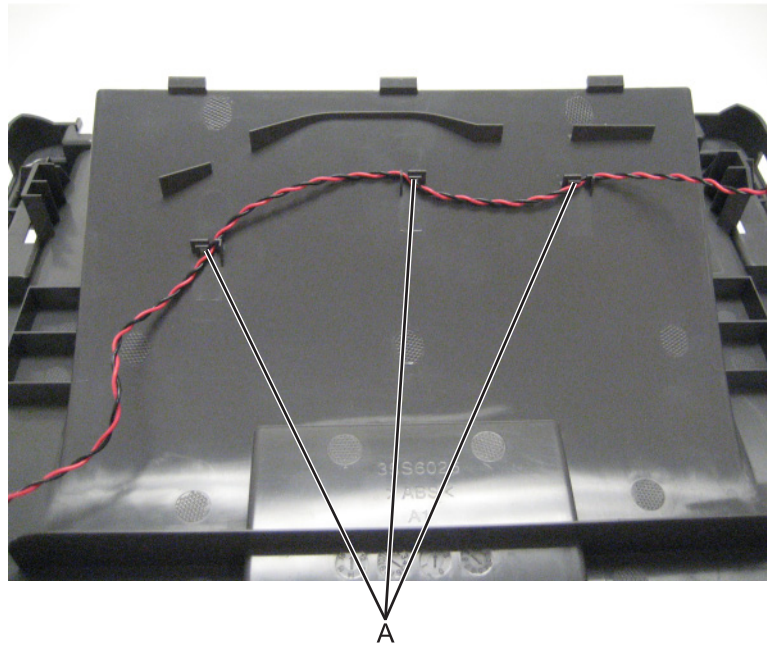

Laser scanning unit (LSU) removal

Before performing this task, determine first whether your printer supports a galvo or polygon LSU.

- Check the serial number of the printer. The LSU is galvo if the sixth digit character assigned is in the 0–9 or B–N range (example: **4514 20HH 007CR**). It is polygon if the sixth digit character assigned is in the P–Z range (example: **4514 2ZHH 007CR**).

MFP printhead adjustment

After re-installing the current LSU or installing a new LSU, a mechanical and electronic LSU adjustment must be performed. Before starting the LSU removal, disable the scanner in the configuration menu. After removing the scanner assembly from the MFP, remove the control panel assembly from the scanner. Attach the control panel assembly cable directly to JUICC on the controller board.



After installing the LSU, perform the mechanical and electronic LSU adjustments with the printer in this configuration. When the LSU is properly adjusted, re-install the control panel assembly to the scanner, and then re-install the scanner assembly to the MFP.

Removal procedure

- 1 Remove the top cover. See [“Top cover removal” on page 391](#).
- 2 Disconnect the cable J6 from the controller board.
- 3 Disconnect the cable (A) from the LSU.

- 4 Before loosening the screws securing the LSU, use a sharp pencil or a small, flat-blade screwdriver to mark the location of the LSU on the printer frame. This will be helpful in positioning the new LSU.



- 5 Remove the LSU.

The color and location of the cables as well as the screws vary depending on the type of LSU that the printer supports.

- For the Galvo LSU, disconnect the two cables (A), and then remove the three screws (B).

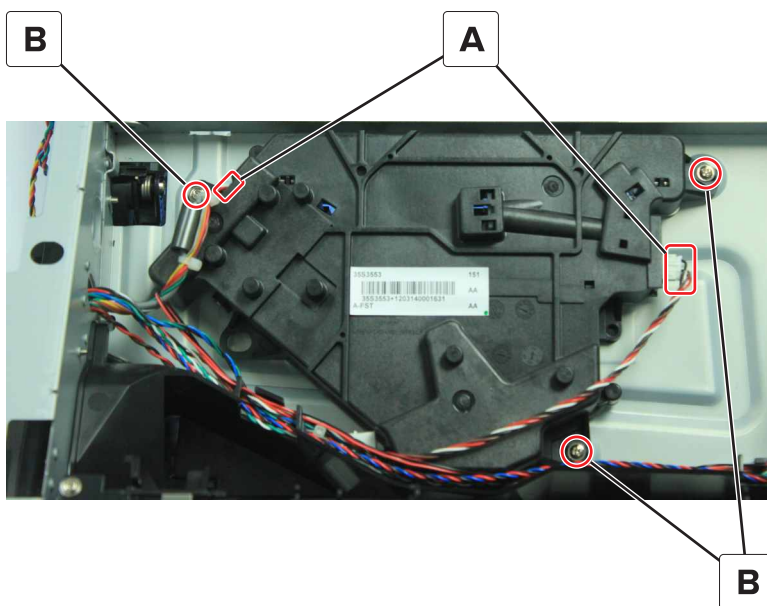

- For the Polygon LSU, disconnect the cable (A), remove the three screws (B), and then disconnect the cable JLSU1 from the controller board.

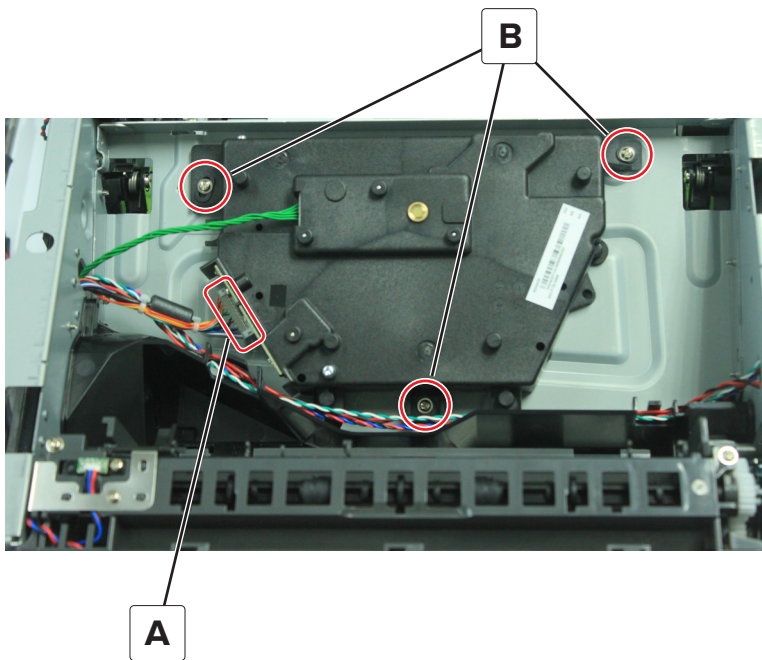

Installation notes:

- Mechanical and electronic LSU adjustments are required to complete the installation of the LSU. See [“Printhead assembly adjustments” on page 299](#).
- When reinstalling the polygon LSU, make sure to follow the sequence, as indicated by the number, in the tightening of the screws; otherwise, 111.xx error would occur.

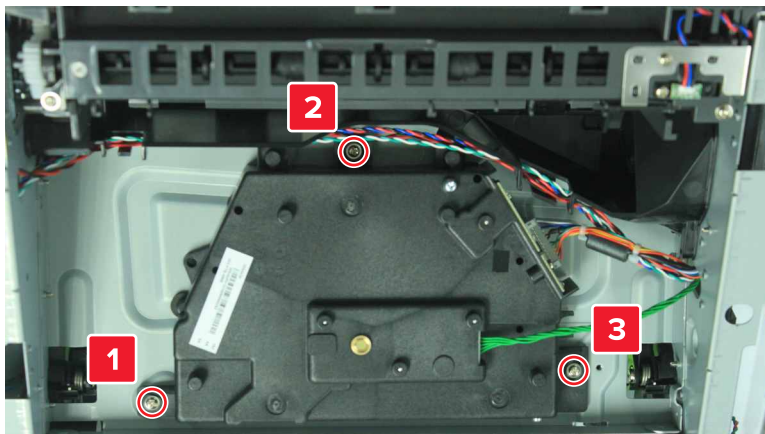

ADF/scanner removals

ADF separator roll removal

- 1 Open the ADF top cover.



- 2 Squeeze the latches to release the separator roll.

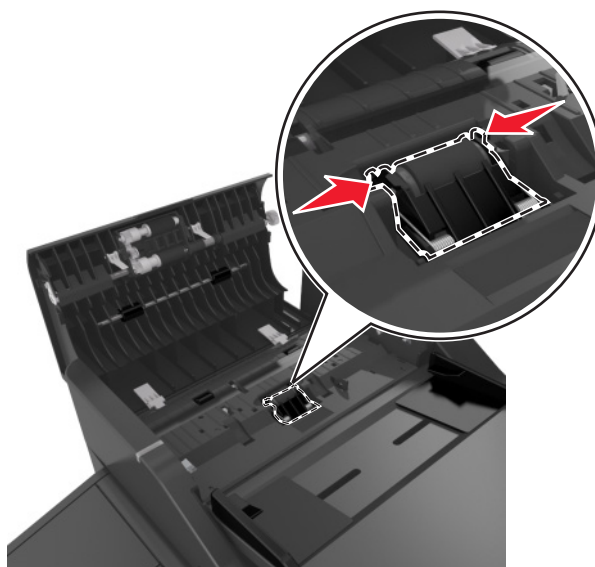

3 Pull away the separator roll and remove.

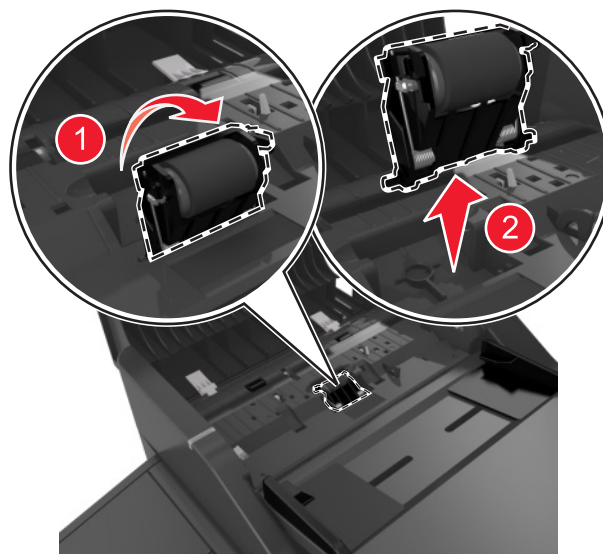

Flatbed cushion removal

1 Open the scanner.



- 2 Hold the cushion by its handles, then peel it off the scanner.

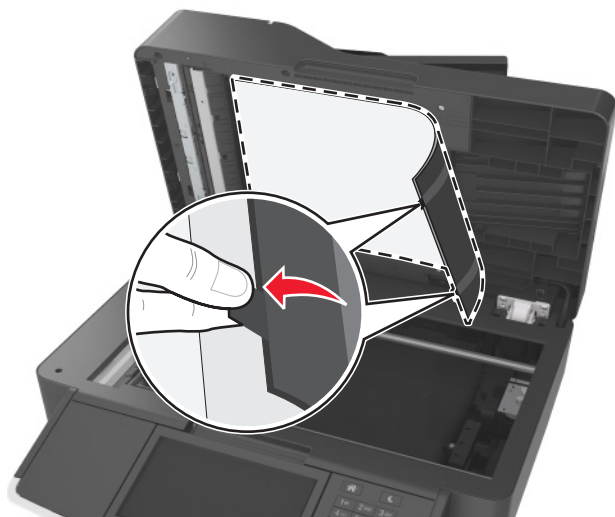

Scanner front cover removal

- 1 Open the front cover.
- 2 Pull down the cover and remove.



ADF input tray removal

- 1 Firmly grasp the tray with one hand.
- 2 Release the tray by pushing its front edge inwards, and then remove the tray.

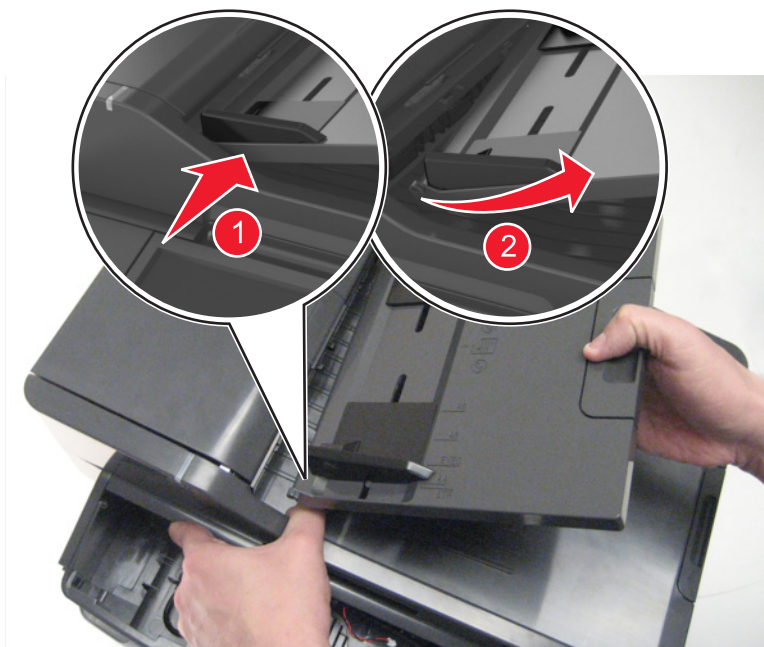

ADF unit removal

- 1 Open the ADF unit with one hand.
- 2 Insert a flat-blade screwdriver into the slot, and release the tab fastening the ADF harness cover to the ADF unit.



- 3** Disconnect the blade fastener (A) holding the ground cable to the ADF relay board.



- 4** Disconnect the ADF cable (B) from the ADF unit.



- 5** Route the cable off the ADF unit.

- 6 Slightly lift the ADF, and use a flat-blade screwdriver to press the tab on the right hinge, releasing it from the flatbed unit.

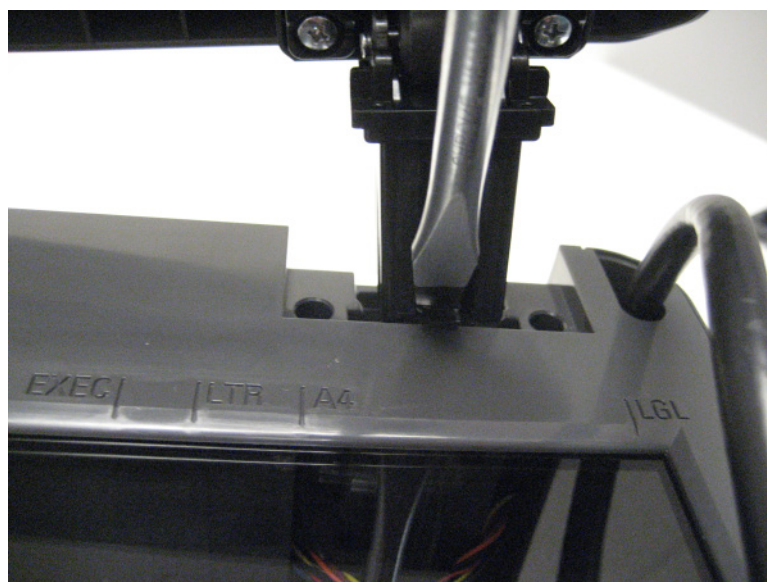

7 Remove the ADF unit.

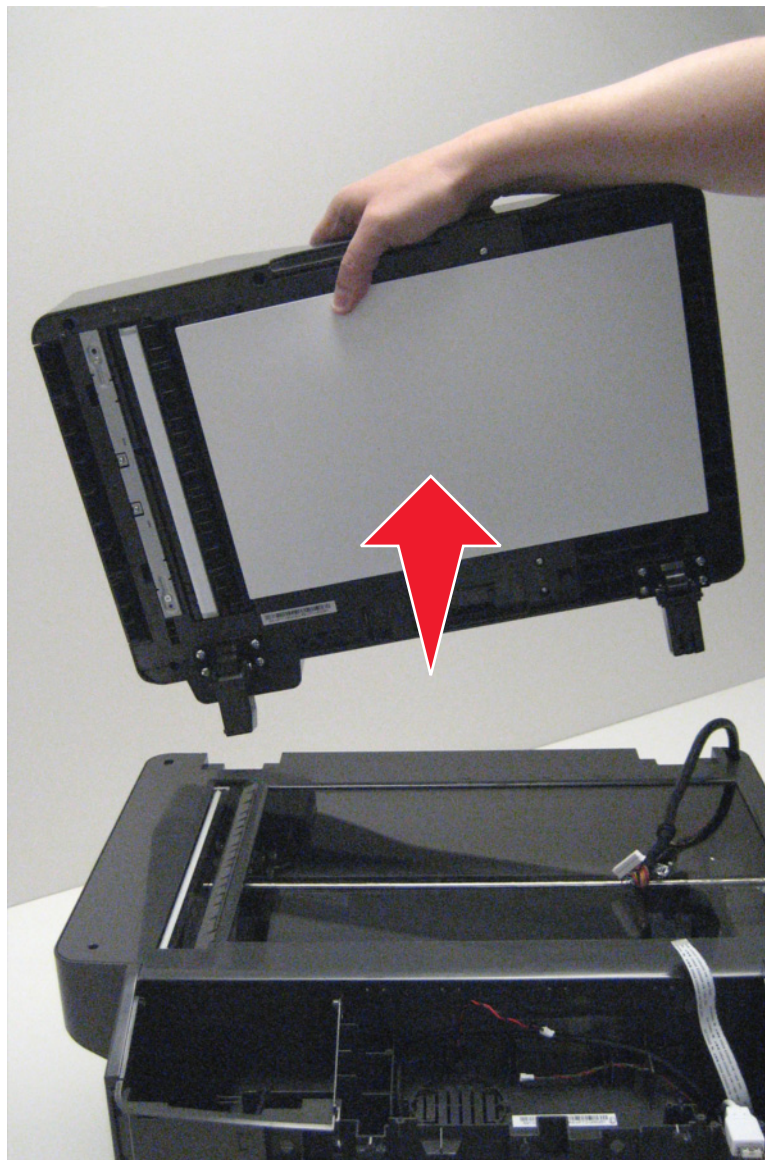

Installation note: After the new ADF is installed, perform scanner manual registration, see [“Scanner manual registration” on page 265](#) and scanner calibration, see [“Scanner calibration” on page 241](#).

Scanner assembly removal

- 1 Remove the diverter cover. See [“Diverter cover removal” on page 390](#).
- 2 Remove the rear cover assembly. See [“Rear cover removal” on page 382](#).
- 3 Open the front access cover. See [“Front access cover removal” on page 354](#).
- 4 Remove the left cover. See [“Left cover removal” on page 302](#).
- 5 Remove the right cover. See [“Right cover removal” on page 315](#).
- 6 Remove the controller board shield. See [“Controller board shield removal” on page 322](#).

- 7 Disconnect the following cables from the RIP board: ADF ground, ADF cable (JADF1), CCD cable (J30), control panel cable (JUICC1), paper length sensor cable (JPLEN1), home sensor cable (JHOME1), speaker cable (JAUD1), and flatbed motor cable (JFBM1).
- 8 Disconnect the control panel USB cable and the MFP wireless cable from the controller board.
- 9 On the rear side of the printer, remove the two screws (A) securing the right side of the scanner assembly to the printer frame.

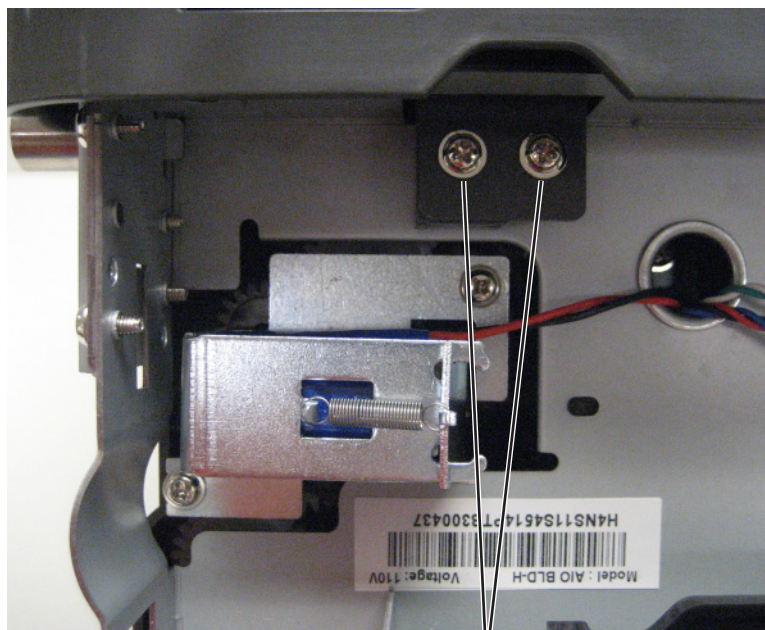

A

- 10 Remove the two screws (B) securing the left side of the scanner assembly to the printer frame.

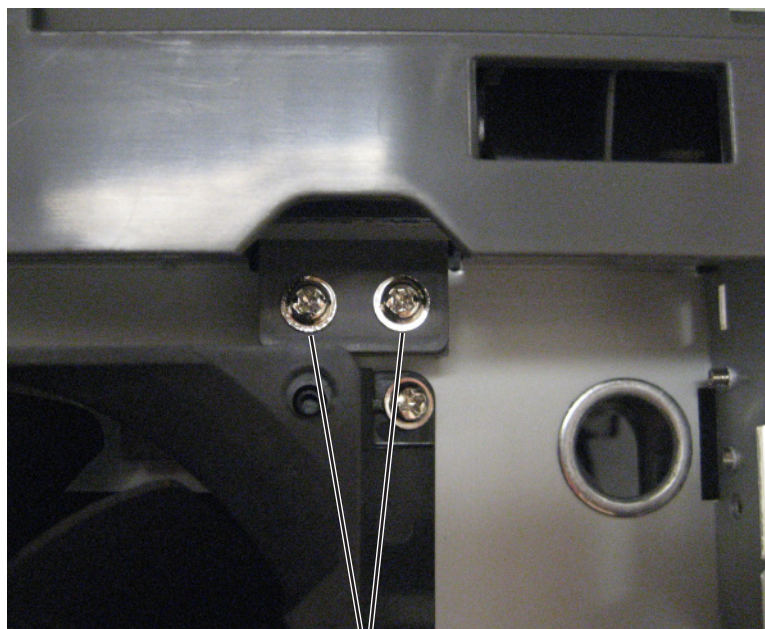

B

Parts removal

- 11 Remove the two screws (C) on the front of the device securing the scanner assembly to the printer frame.

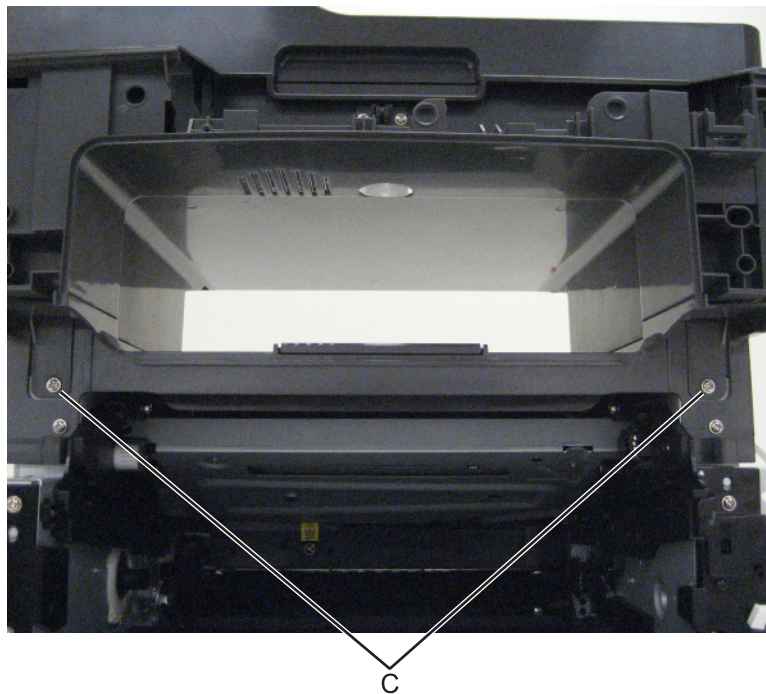

- 12 Lift the complete scanner assembly away from the printer, and remove.

Installation note: After the new scanner assembly is installed, perform scanner manual registration, see [“Scanner manual registration” on page 265](#) and scanner calibration, see [“Scanner calibration” on page 241](#).

ADF top cover assembly removal

- 1 Open the ADF top cover.

Note: Pay attention to the original position of the top cover.

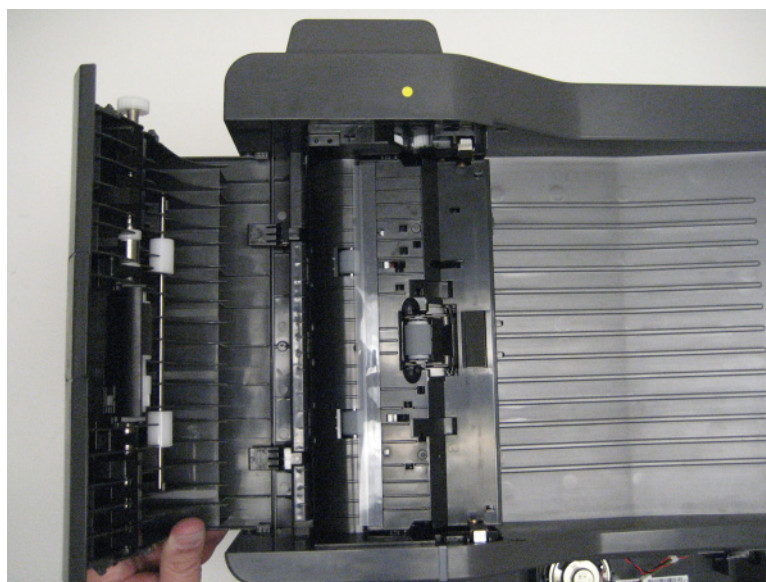

- 2 Release the cover by gently bending the ADF away from the top cover (1), and then lift the top cover (2) and remove.

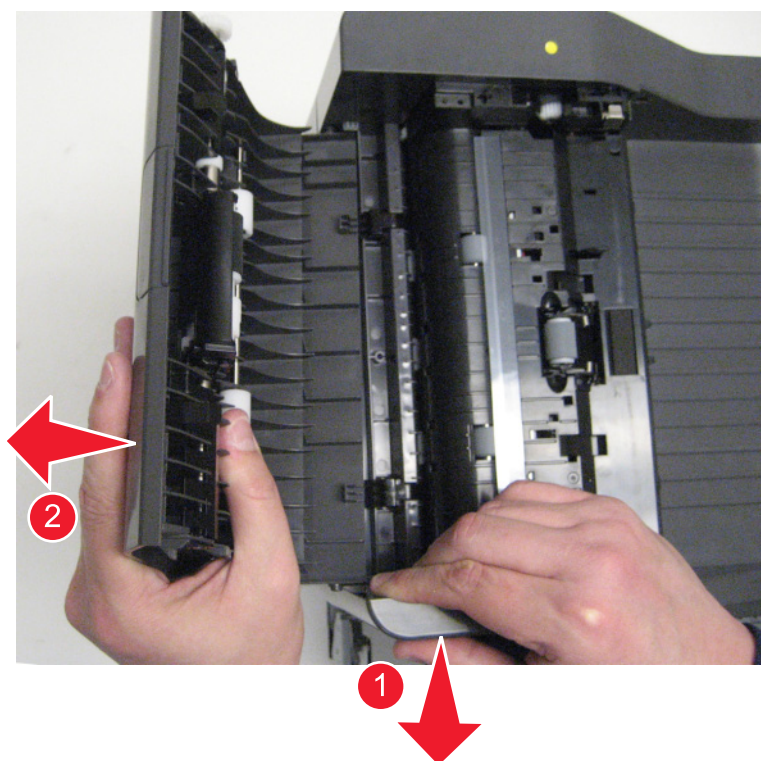

ADF cable removal

- 1 Remove the ADF unit. See [“ADF unit removal” on page 402](#).
- 2 Using a flat-blade screwdriver, remove the cable cover from the rear of the scanner assembly.



- 3 Remove the scanner assembly from the MFP.

- 4 Route the cable through the flatbed assembly, and remove it from the flatbed assembly.

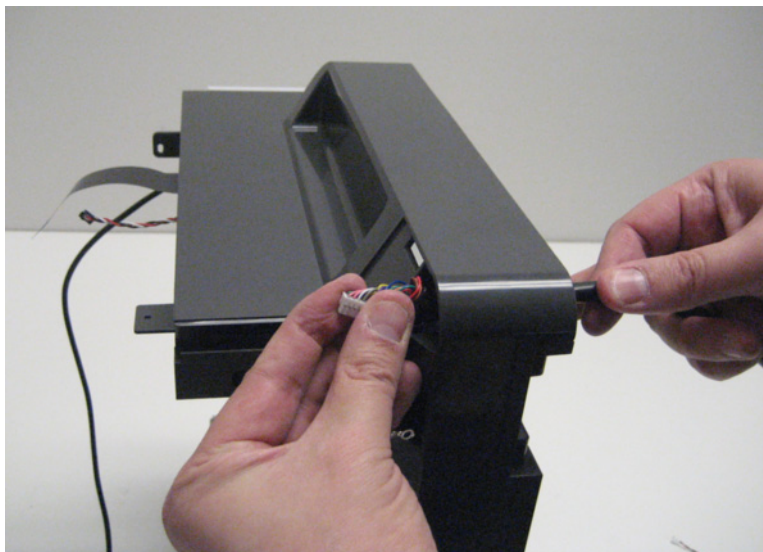

USB cable removal

- 1 Remove the right cover. See [“Right cover removal” on page 315.](#)
- 2 Remove the controller board shield. See [“Controller board shield removal” on page 322.](#)
- 3 Remove the fan.
- 4 Disconnect the MFP wireless cable from the RIP board.
- 5 Remove the scanner front cover. See [“Scanner front cover removal” on page 401.](#)
- 6 Remove the control panel assembly. See [“Control panel assembly removal” on page 336.](#)
- 7 Remove the UICC drip pan.
- 8 Remove the USB cable bracket. See [“USB cable bracket removal” on page 342.](#)

- 9 Feed the USB cable through the channel on the left side of the printer.

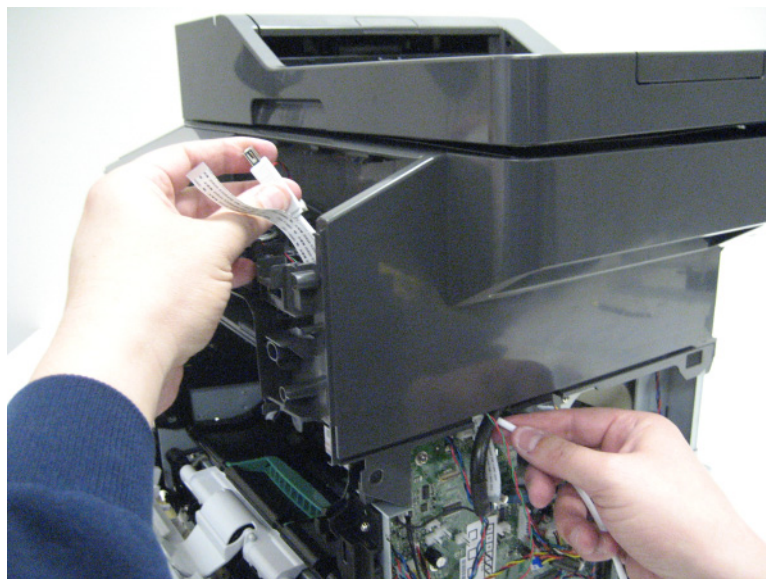

USB wireless cable removal

- 1 Remove the right cover. See [“Right cover removal” on page 315.](#)
- 2 Remove the controller board shield. See [“Controller board shield removal” on page 322.](#)
- 3 Remove the fan.
- 4 Disconnect the MFP wireless cable from the RIP board.
- 5 Remove the scanner front cover. See [“Scanner front cover removal” on page 401.](#)
- 6 Remove the control panel assembly. See [“Control panel assembly removal” on page 336.](#)
- 7 Remove the UICC drip pan.
- 8 Lift the wireless control panel cover.

Note: For MX410 machines, two screws must be removed to release the toroid from the cable.

- 9 Feed the wireless cable through the channel on the left side of the printer.

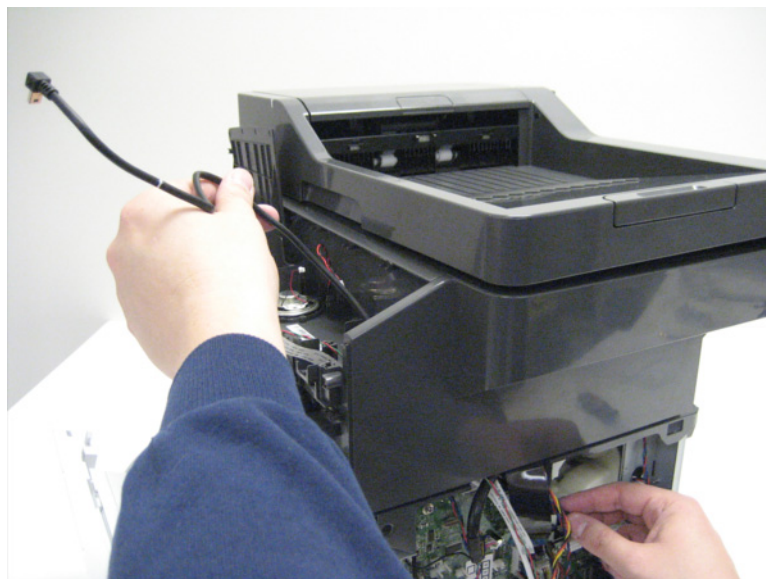

ADF hinge removal

Note: The removal shown is for the left ADF hinge. The right ADF hinge is removed in a similar manner.

- 1 Remove the ADF assembly. See [“ADF unit removal” on page 402](#).
- 2 Remove the four screws (A) securing the ADF hinge to the ADF assembly.

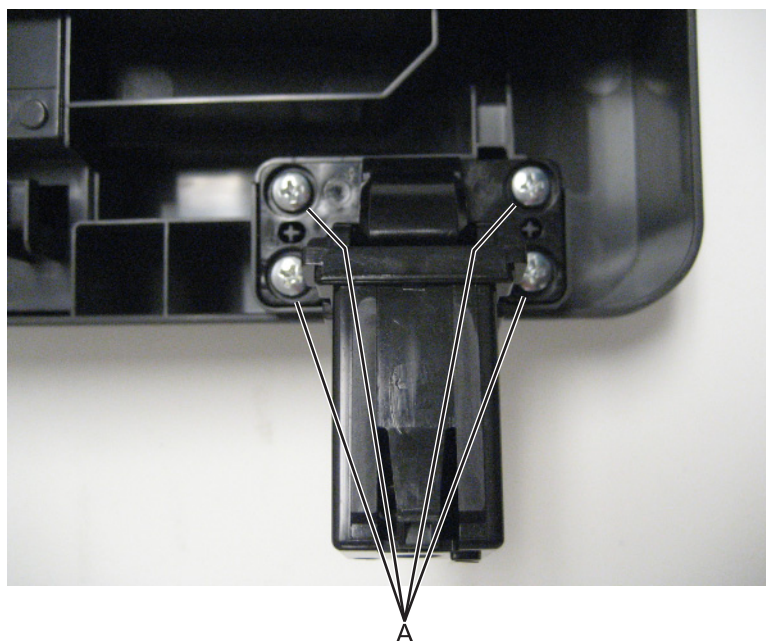

Flatbed assembly removal

- 1 Remove the ADF assembly. See [“ADF unit removal” on page 402.](#)
- 2 Remove the scanner assembly from the MFP. See [“Scanner assembly removal” on page 405.](#)
- 3 Remove the control panel assembly. See [“Control panel assembly removal” on page 336.](#)
- 4 Remove the ADF cable. See [“ADF cable removal” on page 408.](#)
- 5 Remove the USB wireless cable. See [“USB wireless cable removal” on page 410.](#)
- 6 Remove the control panel USB cable. See [“USB cable removal” on page 409.](#)
- 7 Remove the speaker cable. See [“Speaker cable removal” on page 412.](#)
- 8 Remove the wireless control panel cover.

Installation note: After the new flatbed is installed, perform scanner manual registration, see [“Scanner manual registration” on page 265](#) and scanner calibration, see [“Scanner calibration” on page 241.](#)

Control panel ribbon cable removal

- 1 Remove the left cover. See [“Left cover removal” on page 302.](#)
- 2 Remove the scanner front cover. See [“Scanner front cover removal” on page 401.](#)
- 3 Remove the control panel assembly. See [“Control panel assembly removal” on page 336.](#)
- 4 Lift the control panel assembly, disconnect the ribbon cable (JUICC1) from the UICC card, and then feed the ribbon cable through the wire channel.

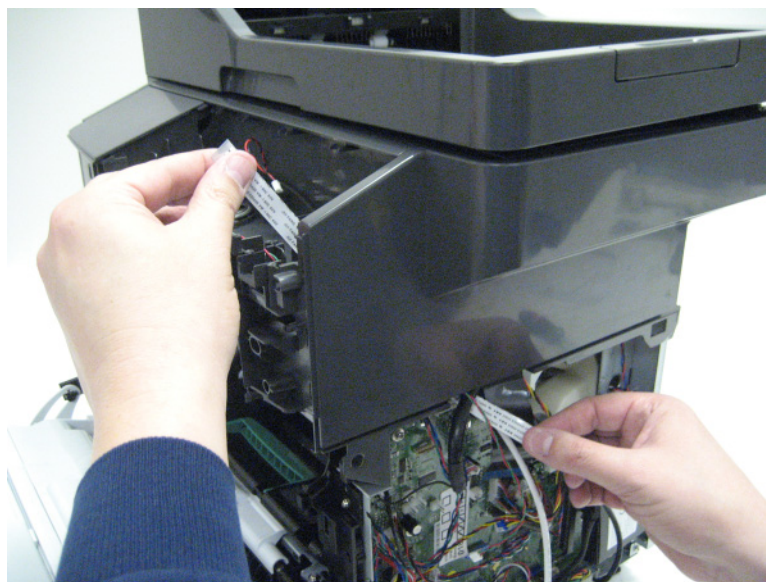

Speaker cable removal

- 1 Remove the left cover. See [“Left cover removal” on page 302.](#)
- 2 Remove the controller board shield. See [“Controller board shield removal” on page 322.](#)

- 3 Remove the fan.
- 4 Remove the scanner front cover. See [“Scanner front cover removal” on page 401.](#)
- 5 Remove the control panel assembly. See [“Control panel assembly removal” on page 336.](#)
- 6 Disconnect the speaker cable from the controller board.

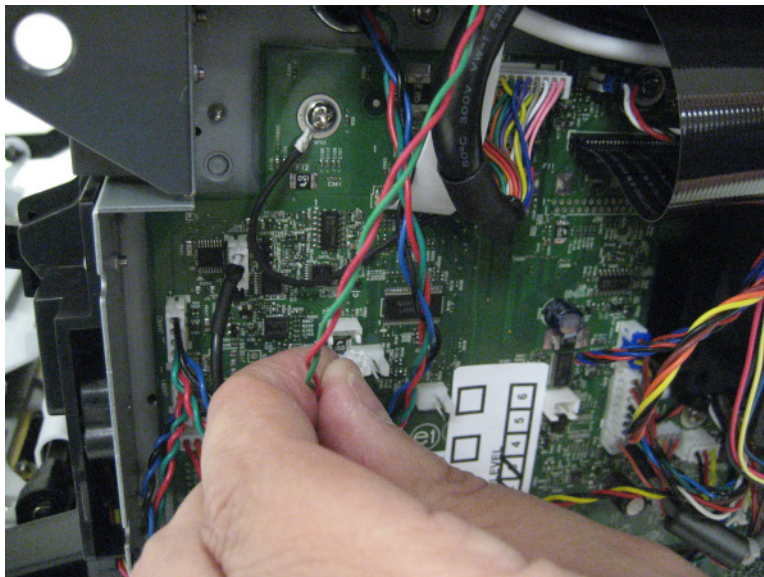

- 7 Disconnect the speaker cable from the speaker.

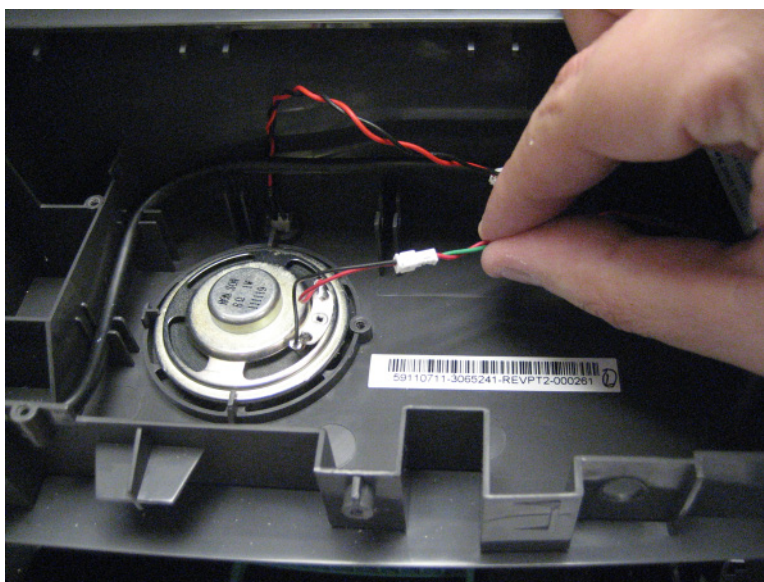

- 8 Feed the speaker cable through the channel on the right side of the printer.

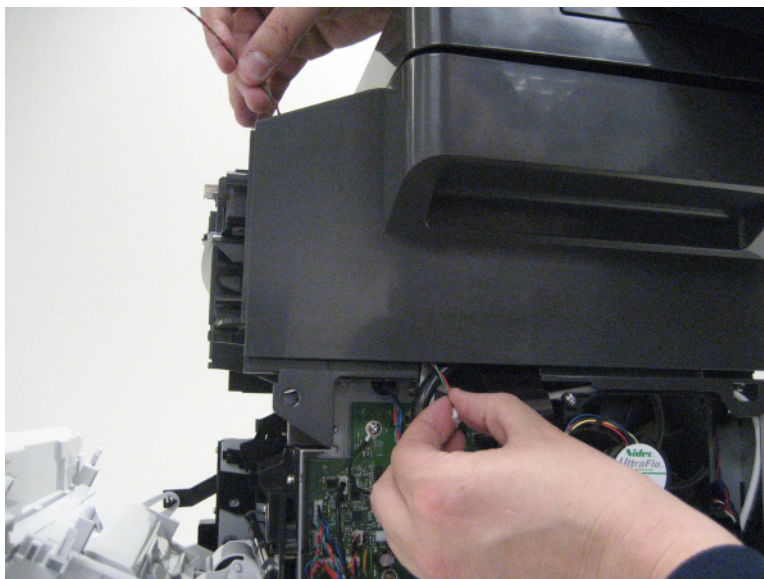

Restraint pad removal

- 1 Open the ADF top cover.
- 2 Peel the restraint pad off of the ADF top cover. Be sure that any excess adhesive or pieces of pad are removed from the ADF top cover to avoid misfeeds.

Warning—Potential Damage: Be sure that any excess adhesive or pieces of pad are removed from the ADF top cover to avoid misfeeds. Do not use solvents to remove the residue. This will damage the plastic.

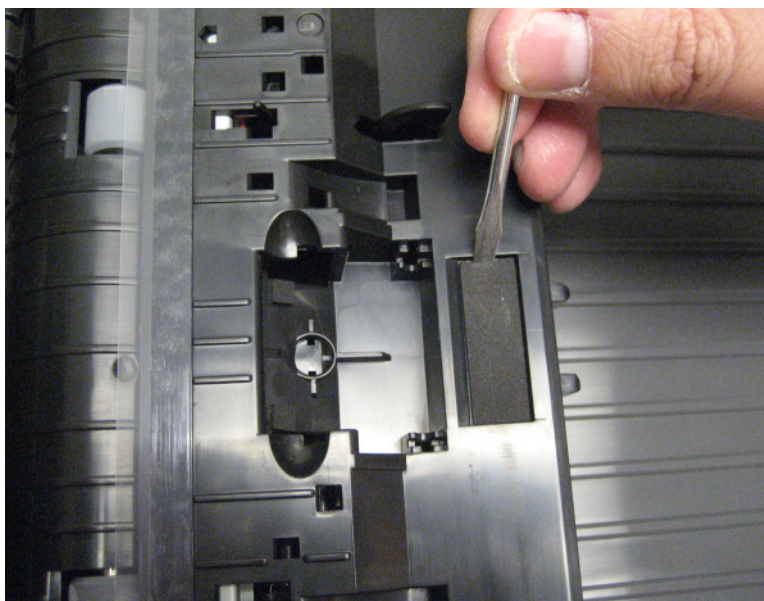

550-sheet option tray removals

Pick roller removal

- 1 Press the latches.
- 2 Remove the pick roller.

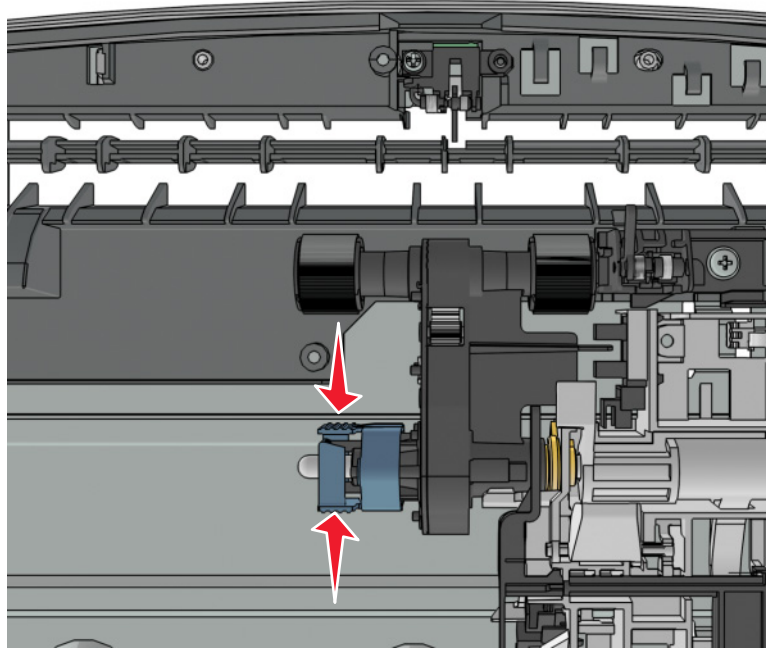

Separator roll assembly removal

- 1 Remove the screw (A) from under the tray insert.

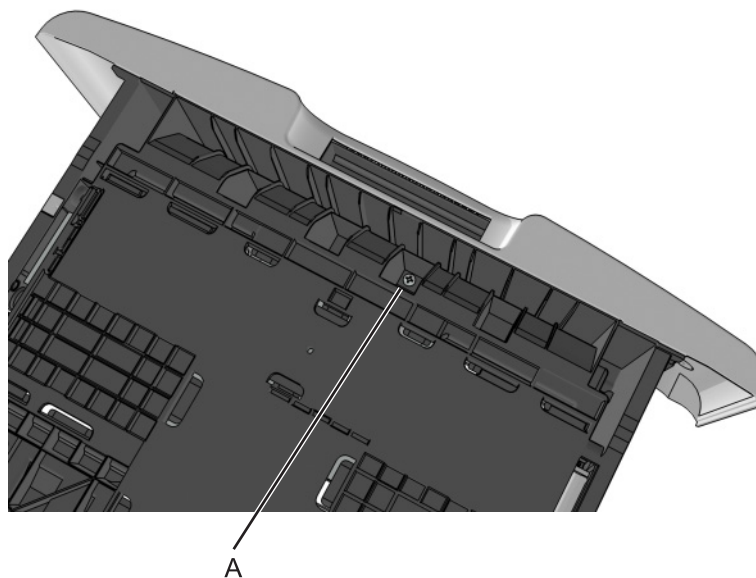

- 2 Remove the E-clip, and then remove the gear.

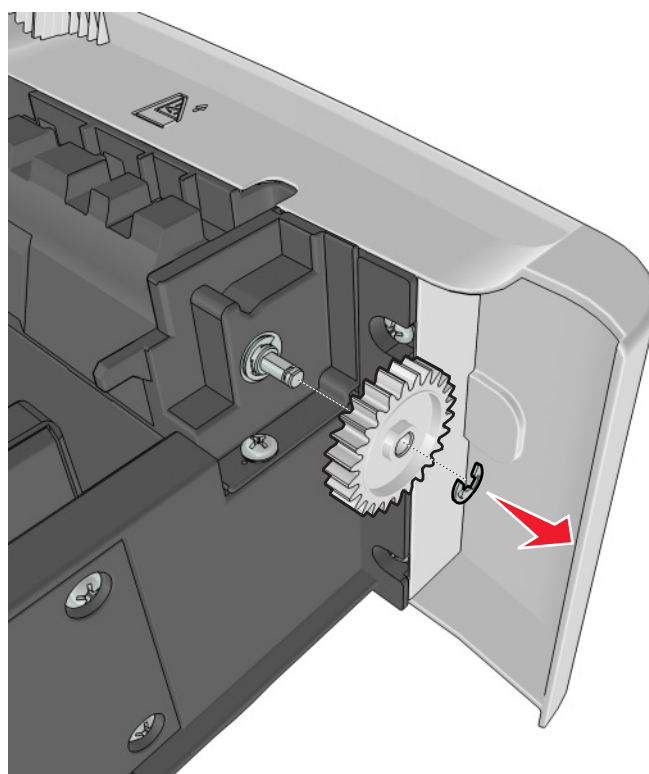

3 Remove the four screws (B).

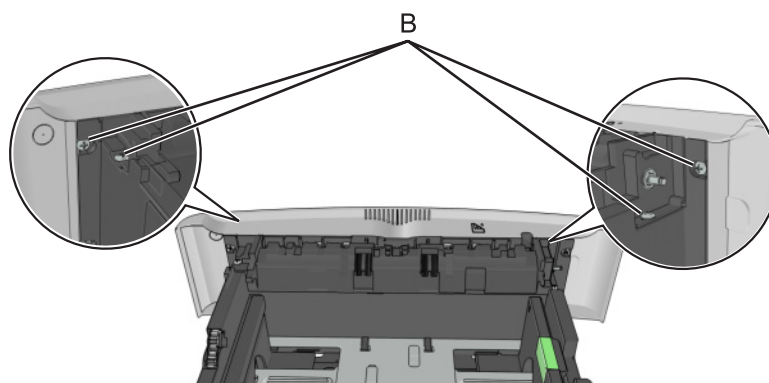

4 Push out the top part of the drawer cover, and then remove the separator roll assembly.

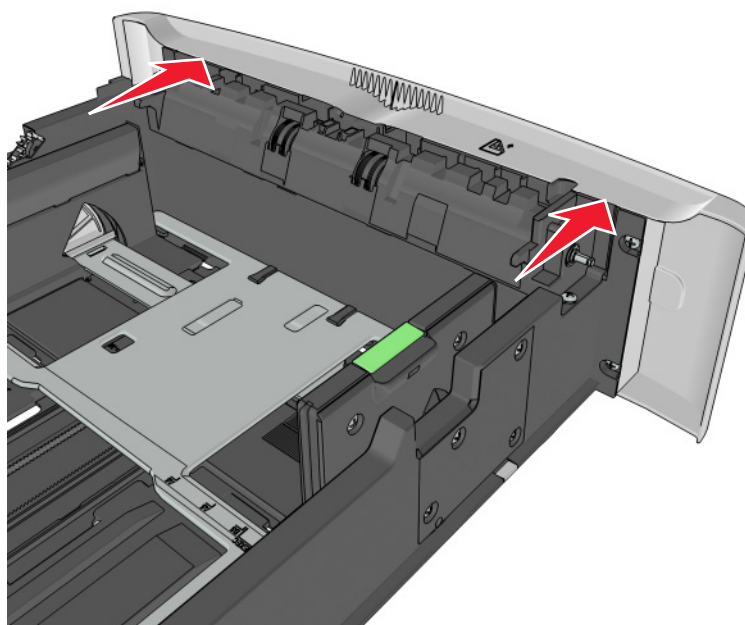

ACM assembly removal

- 1 Remove the seven screws (A), and release the two latches (B) from the top of the drawer.

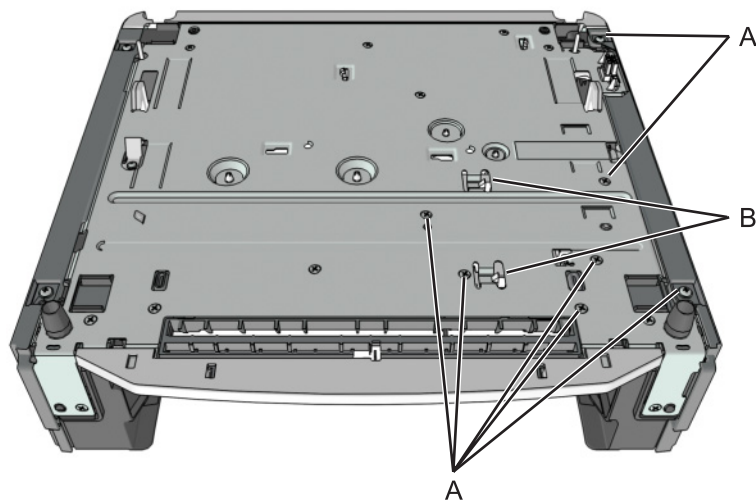

- 2 Remove the two screws (C), and then release the two latches under the screws.

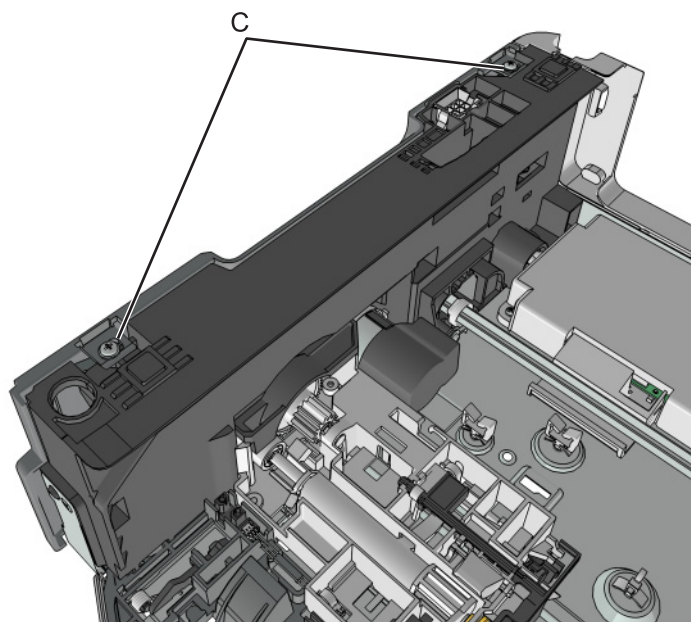

3 Swing the right cover backward to remove.

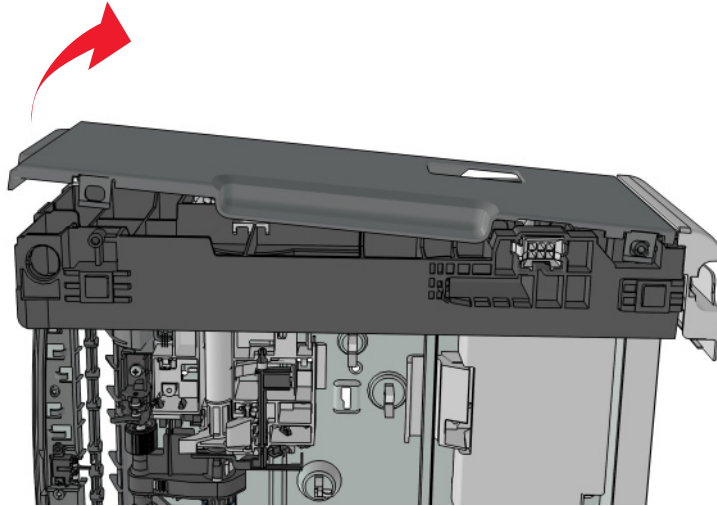

4 Remove the screw (D).

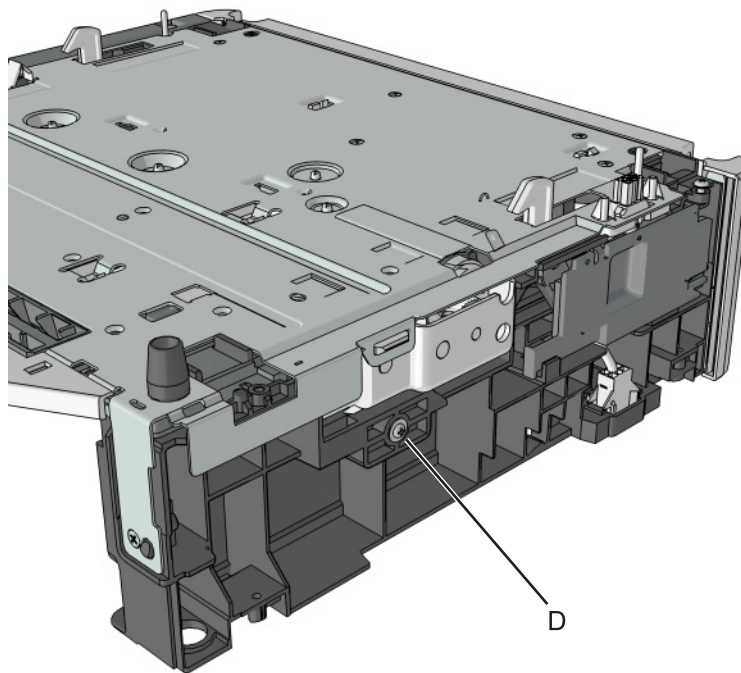

- 5** Disconnect the spring (E).

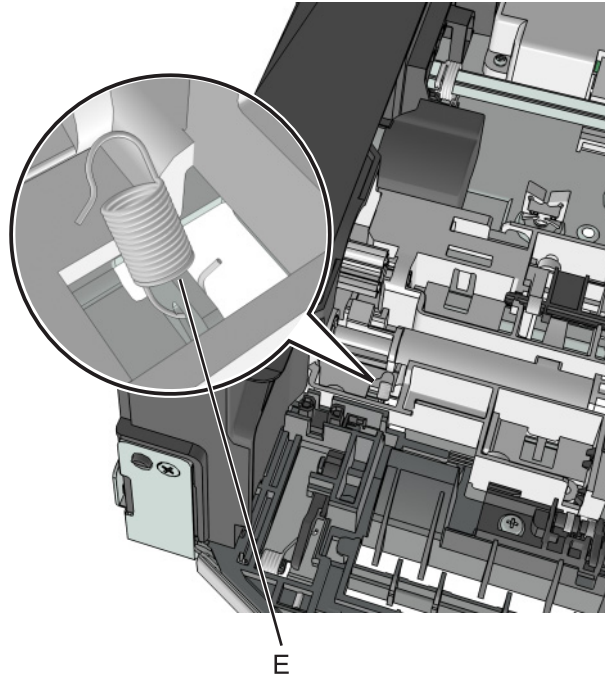

- 6** Remove the two screws (F), and then remove the controller card cover.

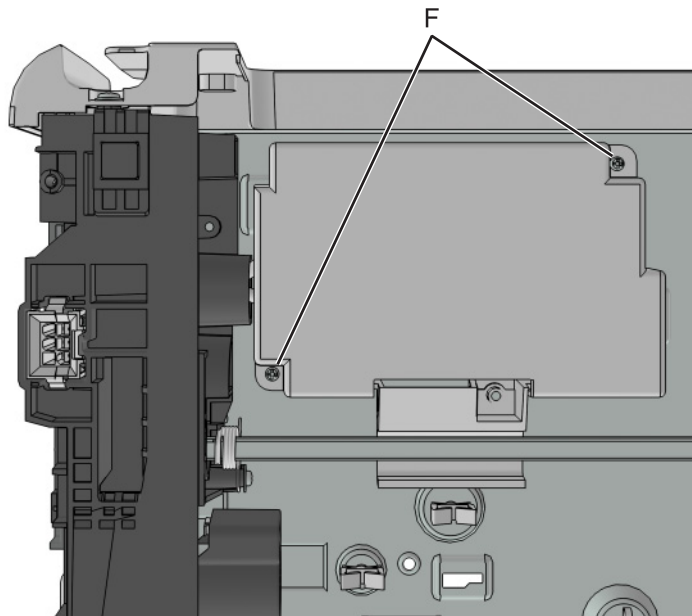

- 7** Disconnect the cable J11 from the controller card.
- 8** Route the cable off the option, and then remove the ACM assembly.

Staple finisher option removals

Staple finisher option removal

- 1 Turn off the machine, unplug it from its power source, and then disconnect the staple finisher power cable from the printer.

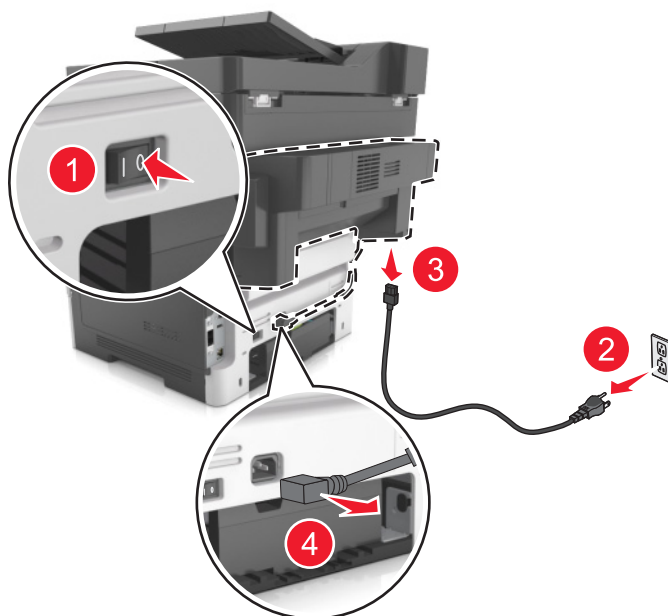

- 2 Press the latches to release, then pull the staple finisher off the printer.

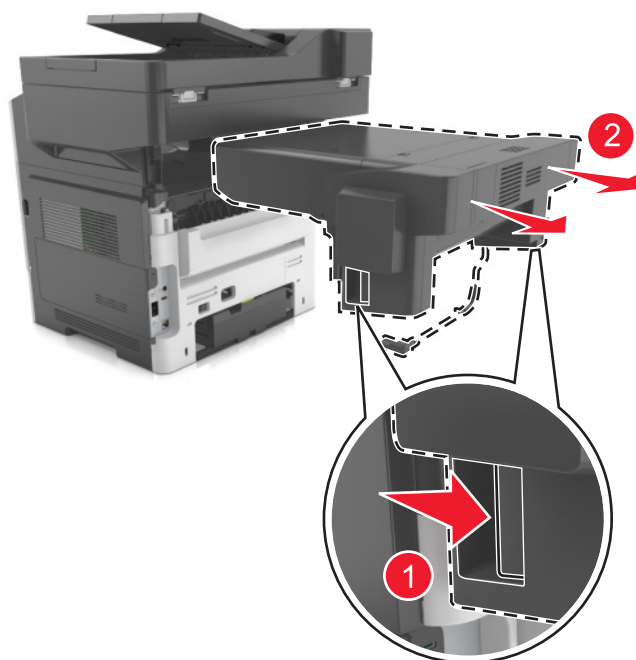

Stapler cartridge access door removal

1 Open the access door.

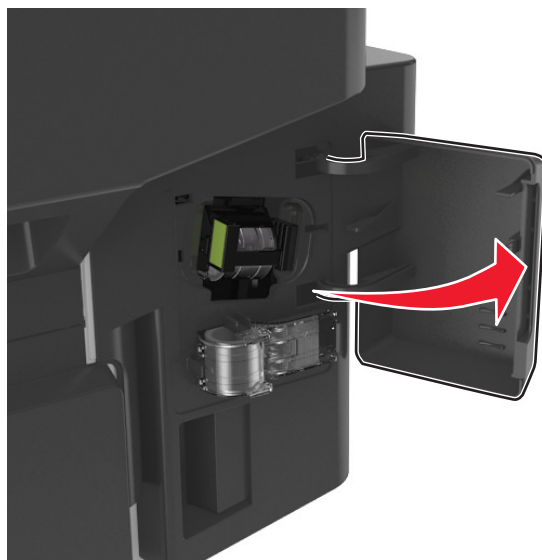

2 Press the hinge inwards to release.

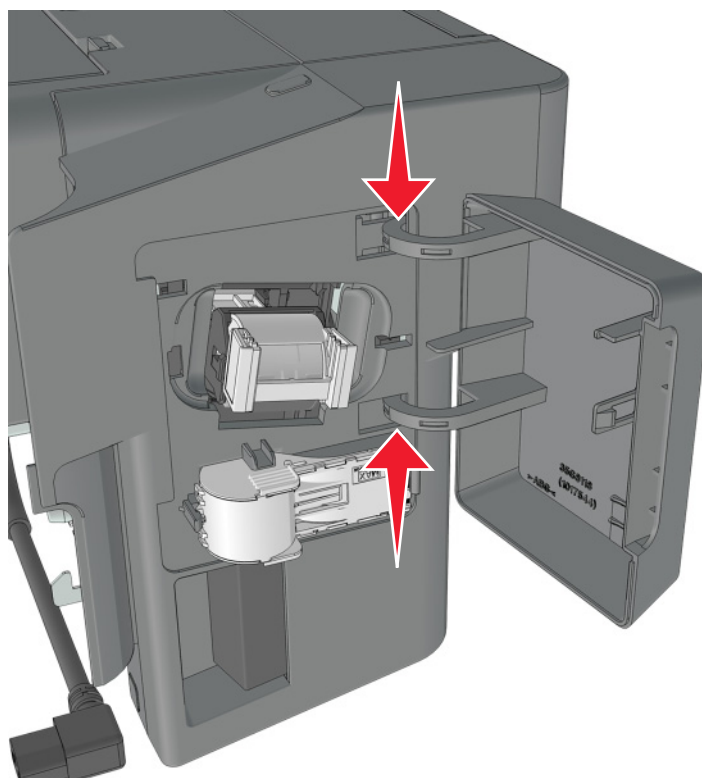

3 Pull the door, and remove.

Staple roll holder removal

- 1 Open the access door.

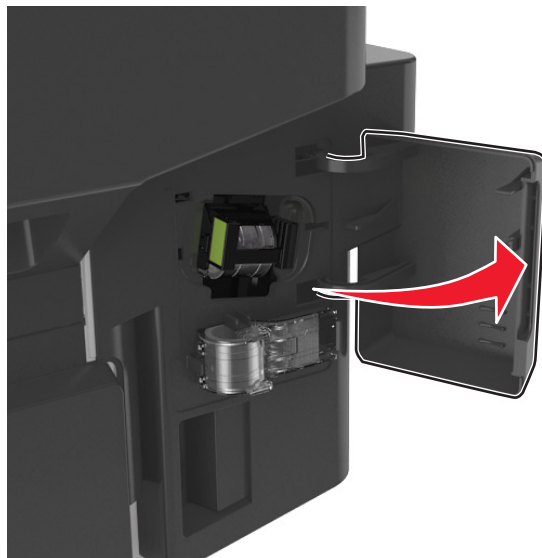

- 2 Squeeze the handles (1), and pull the stapler roll holder (2) off the cartridge.

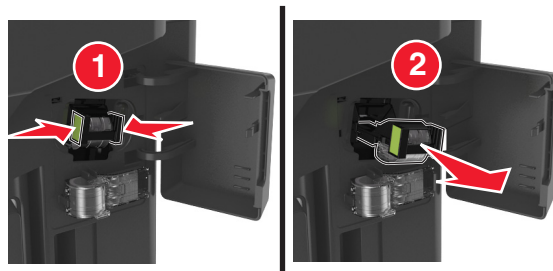

Stapler right cover removal

- 1 Remove the stapler cartridge access door. See [“Stapler cartridge access door removal” on page 422](#).
- 2 Remove the screw (A), then remove the cover.

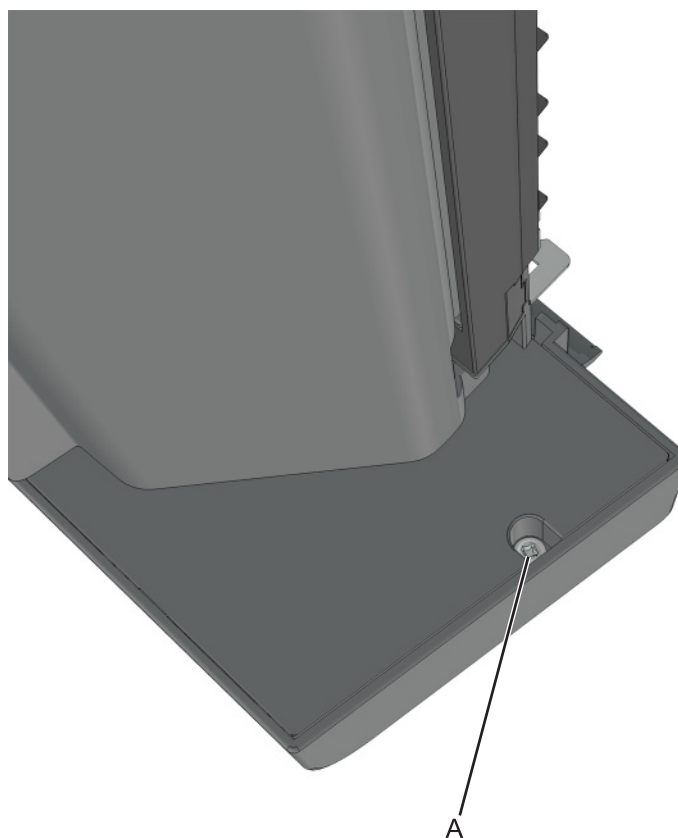

Stapler left cover removal

Note: This is not a FRU.

- 1 Remove the screw (A).

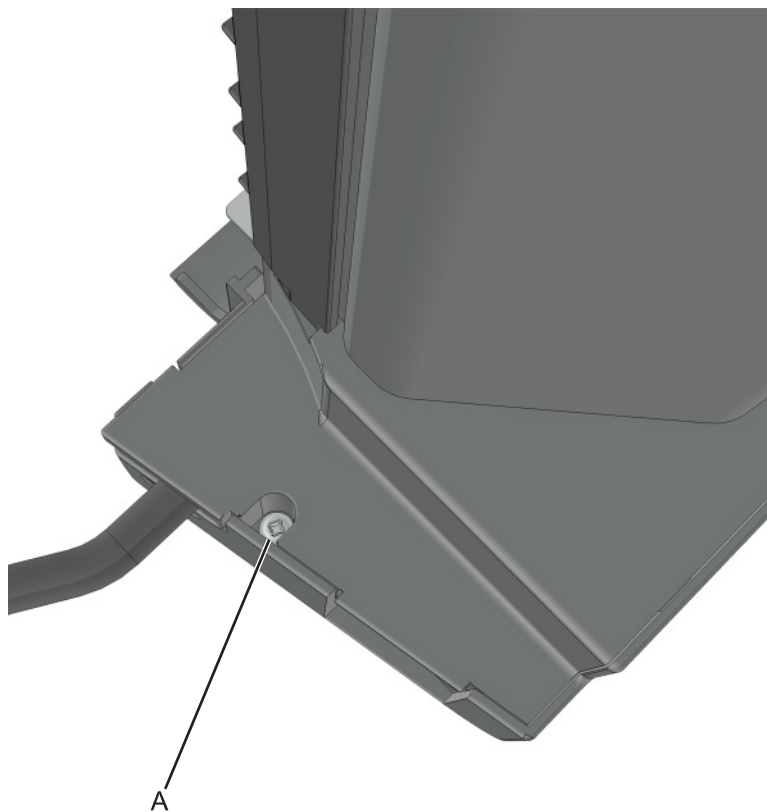

- 2 Remove the cover.

Stapler rear door removal

- 1 On the bottom of the stapler finisher, flex the stapler rear door to release the pin (A).

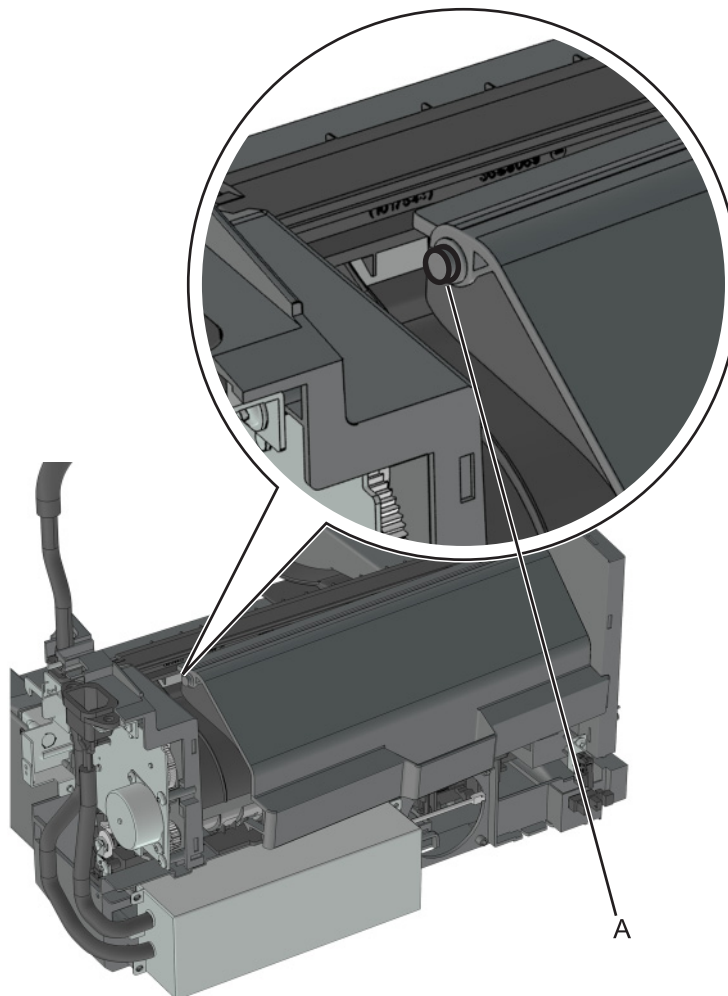

- 2 Remove the stapler rear door.

Sensor (stapler access door) removal

- 1 Remove the stapler right cover. See [“Stapler right cover removal” on page 424.](#)
- 2 Disconnect the sensor cable (A).

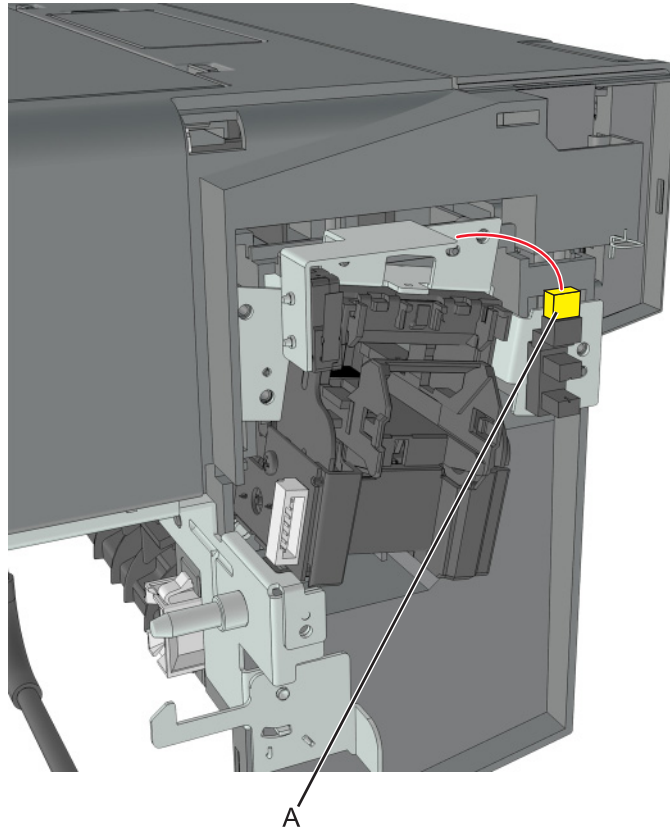

- 3 Release the latches, and pull the sensor off the frame.

Stapler carriage assembly removal

- 1 Remove the stapler right cover. See [“Stapler right cover removal” on page 424.](#)
- 2 Disconnect the cable (A) from the carriage.

- 3** Remove the four screws (B) securing the carriage frame to the stapler.

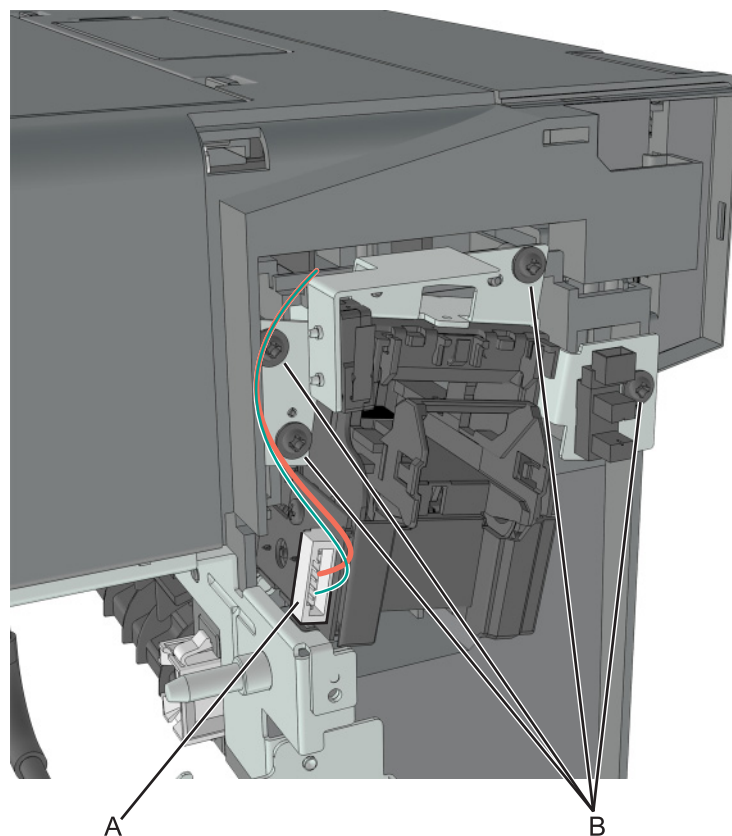

- 4 Remove the two screws (C), and remove the stapler carriage assembly.

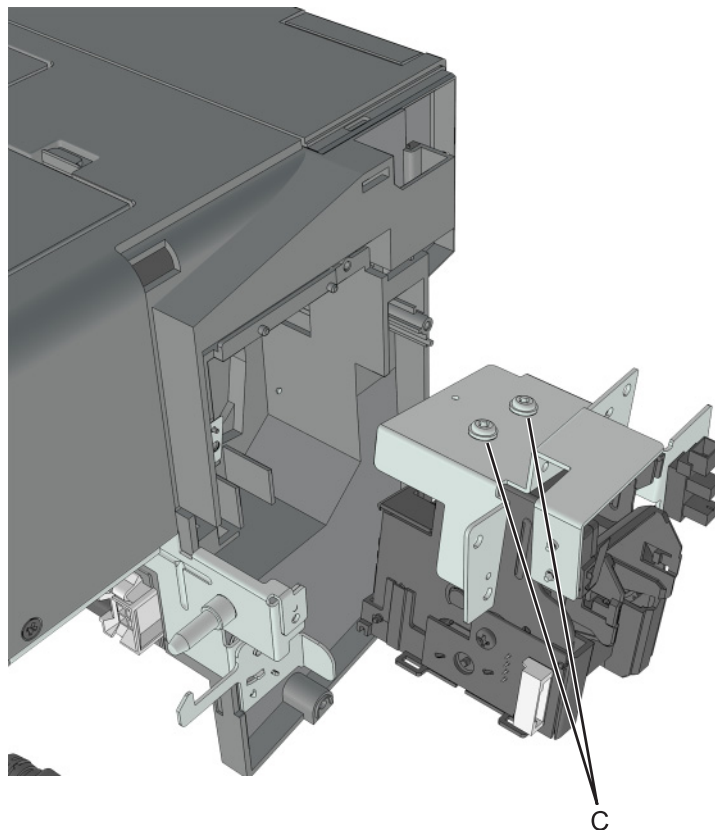

Stapler door close limit switch removal

- 1 Remove the stapler right cover. See [“Stapler right cover removal” on page 424.](#)
- 2 Push down to release, then disconnect the switch cable (A).

3 Remove the four screws (B) securing the carriage frame to the stapler.

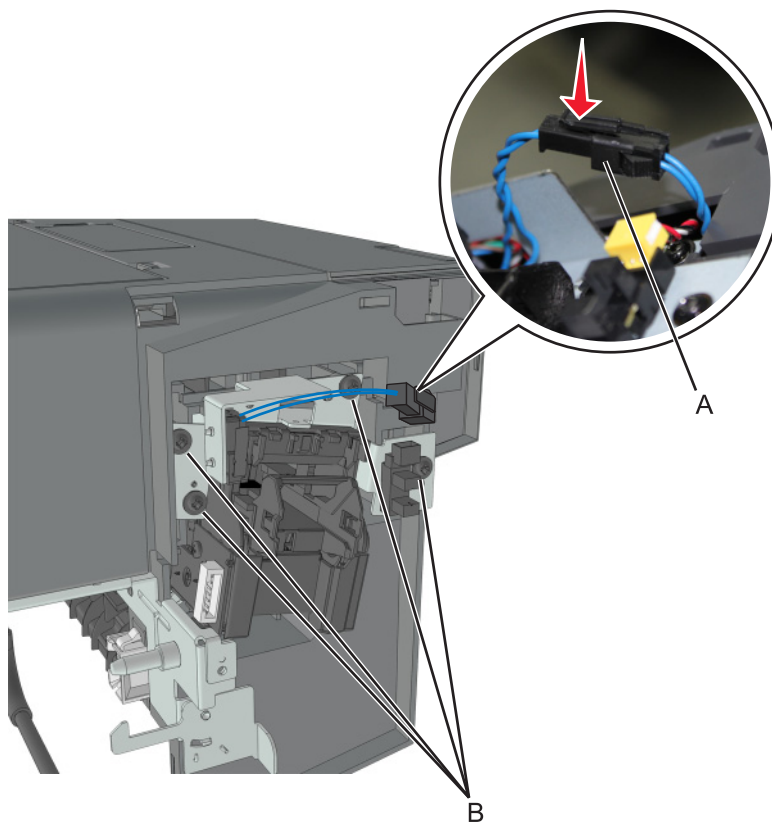

- 4 To access the switch, remove the two screws (C), and set aside the carriage.

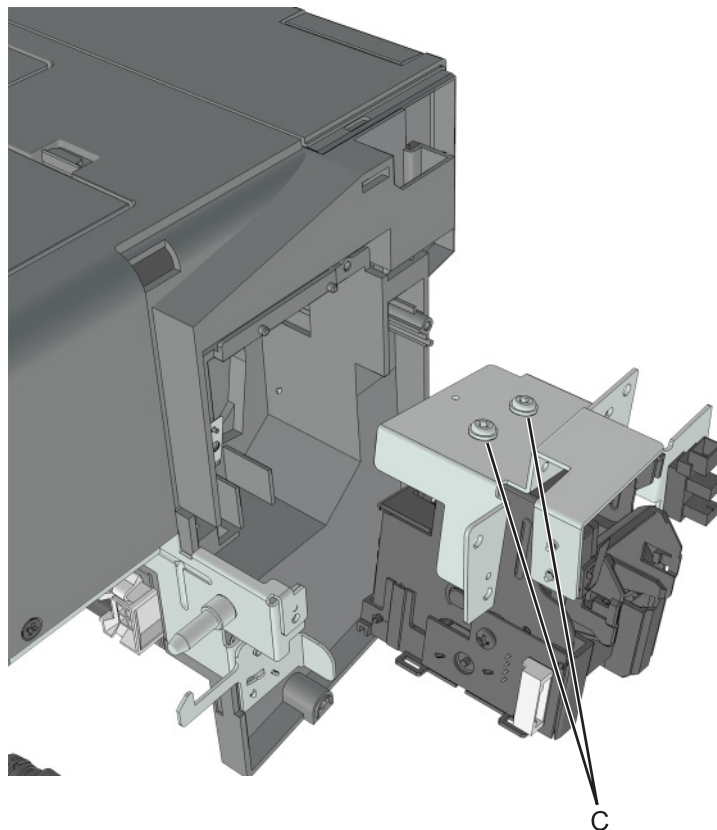

Parts removal

431

- 5 Remove the two screws (D) using a #1 Phillips screwdriver, then remove the limit switch.

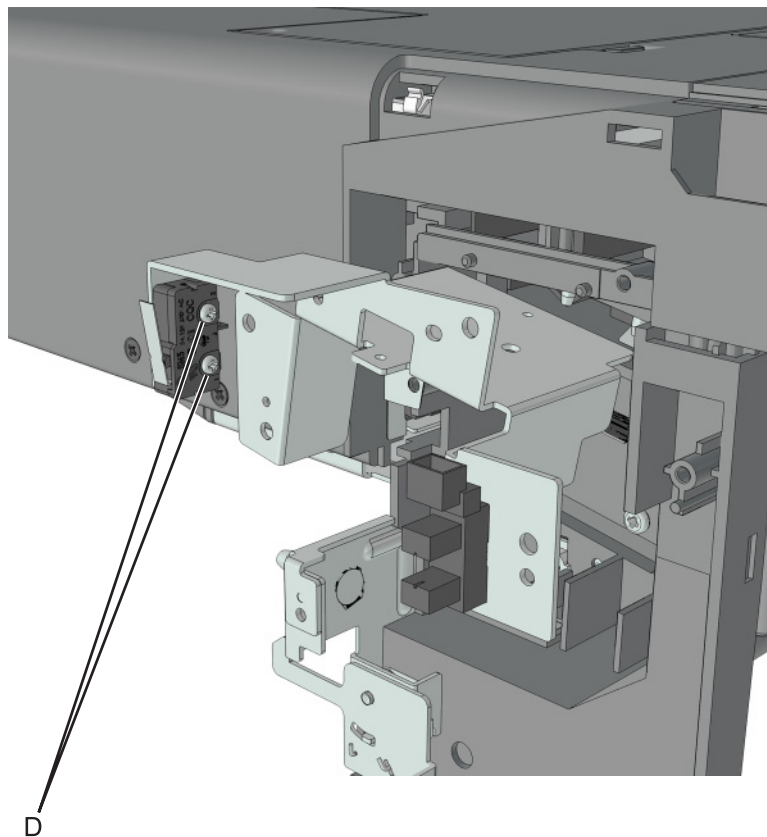

Stapler paddle motor removal

- 1 Remove the stapler left cover. See [“Stapler left cover removal” on page 425.](#)
- 2 Remove the two screws (A) from the paddle motor and disconnect the motor cable (B).

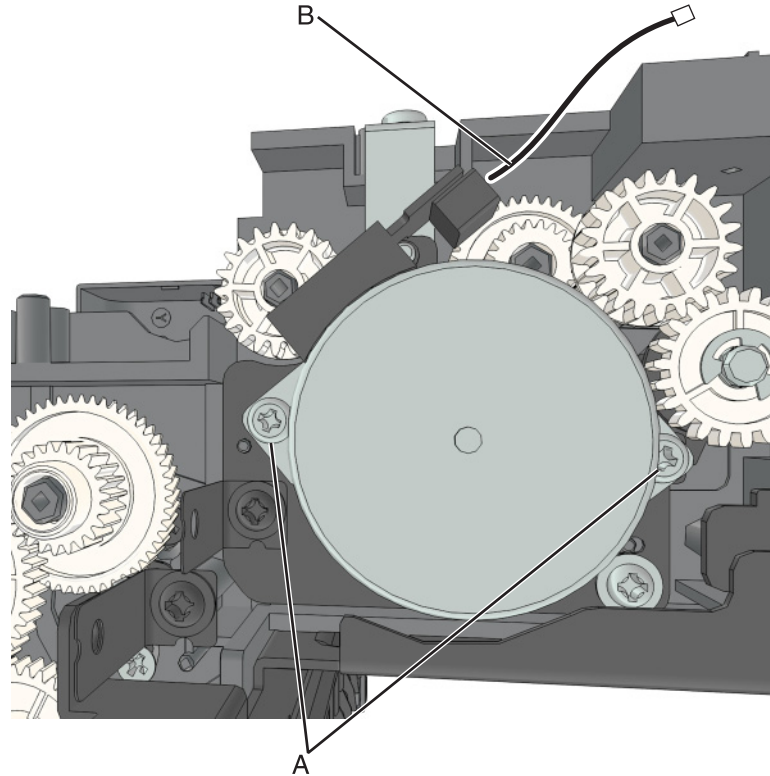

- 3 Remove the motor.

Stapler rear cover removal

- 1 Remove the left cover. See [“Stapler left cover removal” on page 425.](#)
- 2 Remove the right cover. See [“Stapler right cover removal” on page 424.](#)

- 3 Lift the media access door (1), then pull the rear cover (2), and remove.

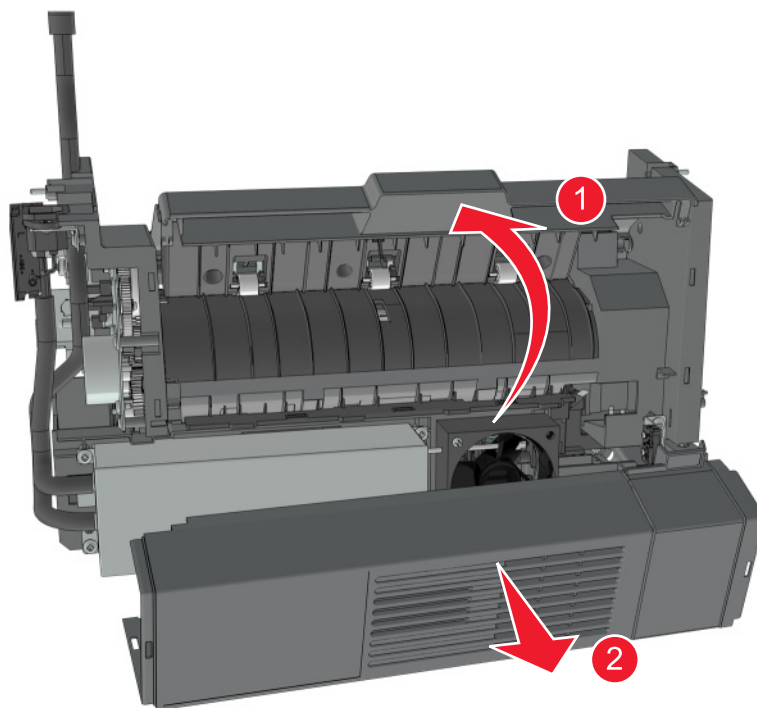

Sensor (stapler rear cover) removal

- 1 Remove the stapler right cover. See [“Stapler right cover removal” on page 424.](#)
- 2 Remove the stapler left cover. See [“Stapler left cover removal” on page 425.](#)
- 3 Remove the stapler rear cover. See [“Stapler rear cover removal” on page 433.](#)

- 4 Disconnect the sensor cable (A).

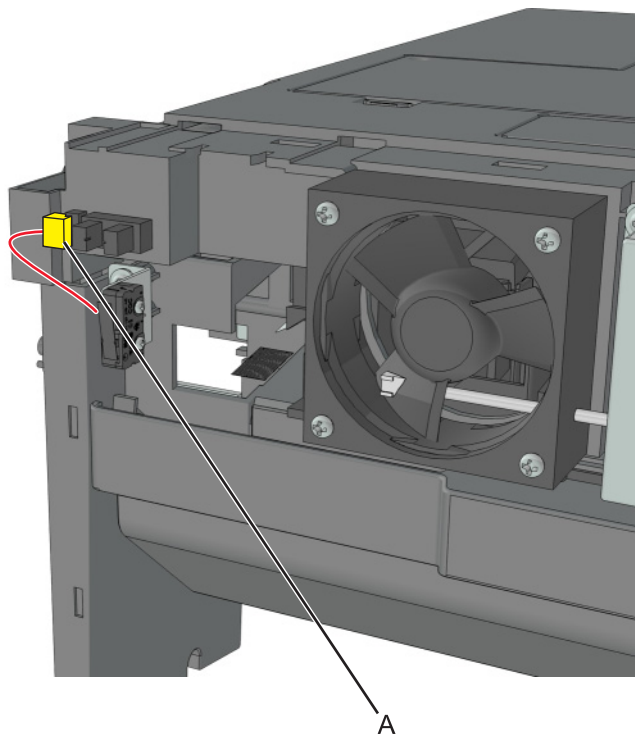

- 5 Release the latches, and pull the sensor off the stapler.

Trapped staple access door removal

- 1 Lift the media access door (1), then open the staple access door (2).

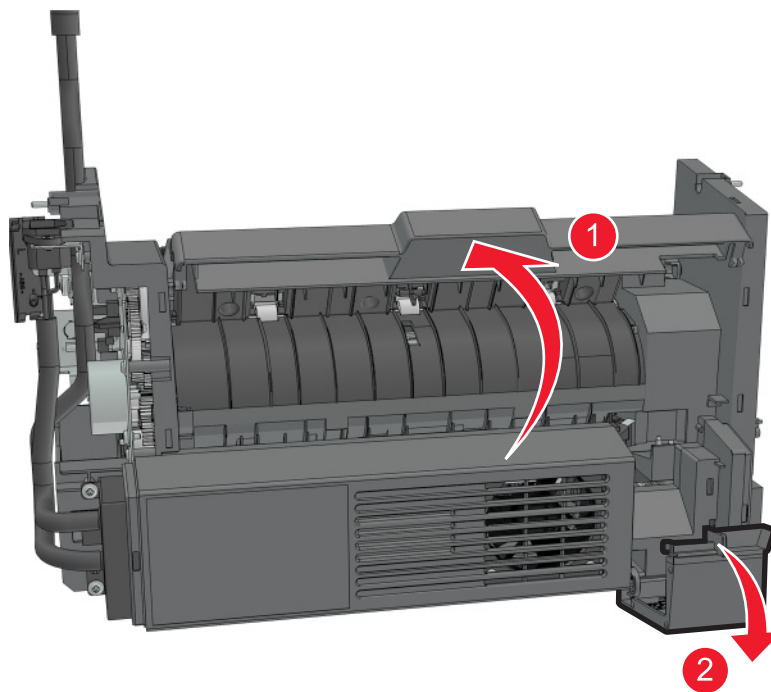

- 2 Push inwards to release the hinges, then remove the staple access door.

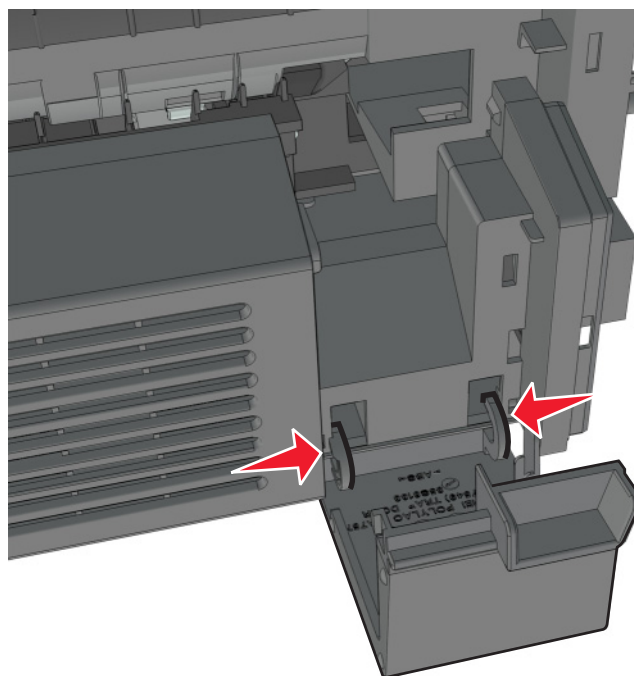

Stapler service cover removal

- 1 Remove the two screws (A) from the cover.
- 2 Press the latches (B) to release, and pull the service cover off the stapler.

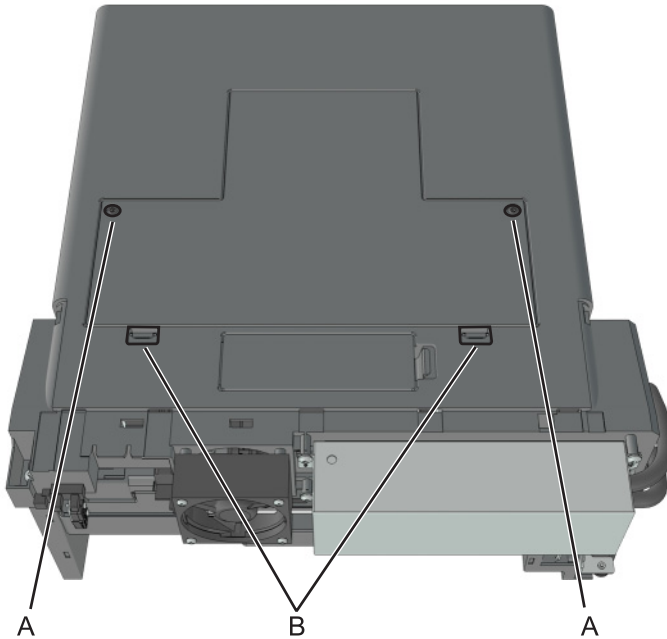

Stapler controller card removal

- 1 Remove the stapler service cover. See [“Stapler service cover removal” on page 437](#).
- 2 Disconnect all the cables from the controller card.
- 3 Remove the five screws (A), then pull the controller card off the stapler.

Stapler left tamper motor removal

- 1 Remove the stapler service cover. See [“Stapler service cover removal” on page 437](#).
- 2 Disconnect the motor cable (A).

- 3 Remove the two screws (B) securing the motor, and remove the tamper motor.

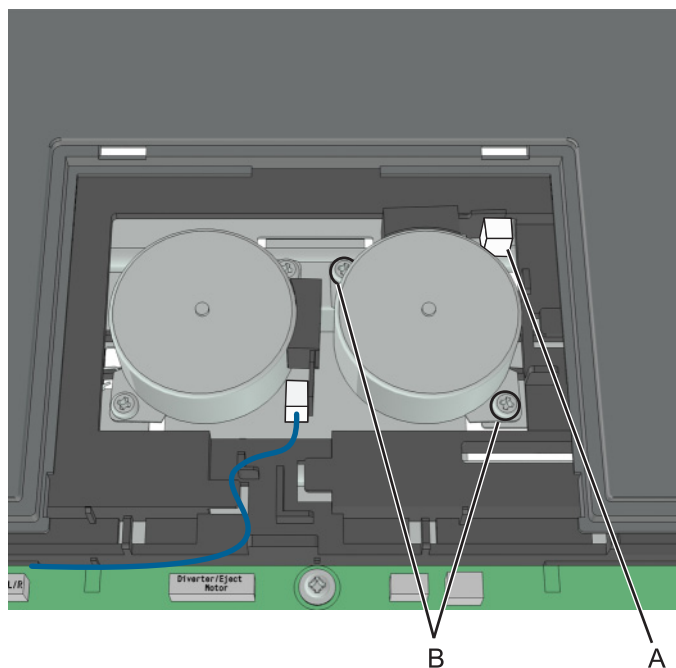

Warning—Potential Damage: Be careful not to lose the tamper belt when removing the tamper motor.

Installation note: Make sure to engage the motor gears with the tamper belt.

Stapler right tamper motor removal

- 1 Remove the stapler service cover. See [“Stapler service cover removal” on page 437](#).
- 2 Remove the two screws (A) securing the motor.

- 3 Disconnect the motor cable (B), and remove the tamper motor.

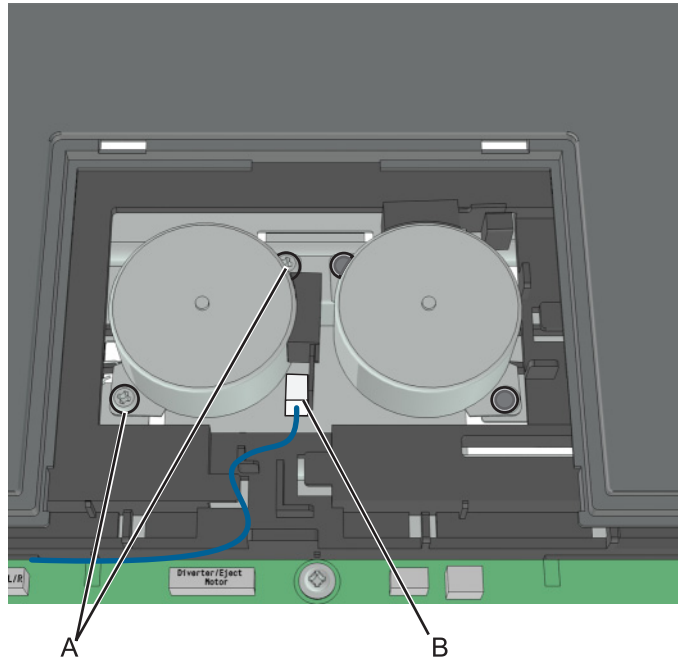

Warning—Potential Damage: Be careful not to lose the tamper belt when removing the tamper motor.

Installation note: Make sure to engage the motor gears with the tamper belt.

Stapler rear cover close limit switch removal

- 1 Remove the stapler service cover. See [“Stapler service cover removal” on page 437.](#)
- 2 Disconnect the limit switch cable from the controller card.
- 3 Remove the stapler right cover. See [“Stapler right cover removal” on page 424.](#)

- 4 Disconnect the sensor cable (A).

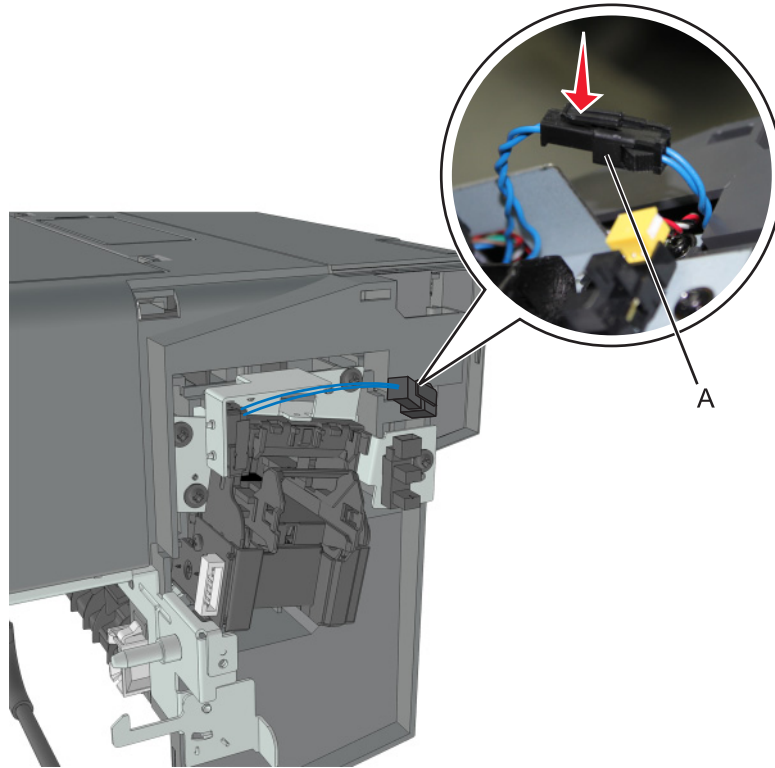

- 5 Remove the stapler left cover. See [“Stapler left cover removal” on page 425.](#)
- 6 Remove the stapler rear cover. See [“Stapler rear cover removal” on page 433.](#)
- 7 Remove the two screws (B) using a #1 Phillips screwdriver, then remove the limit switch.

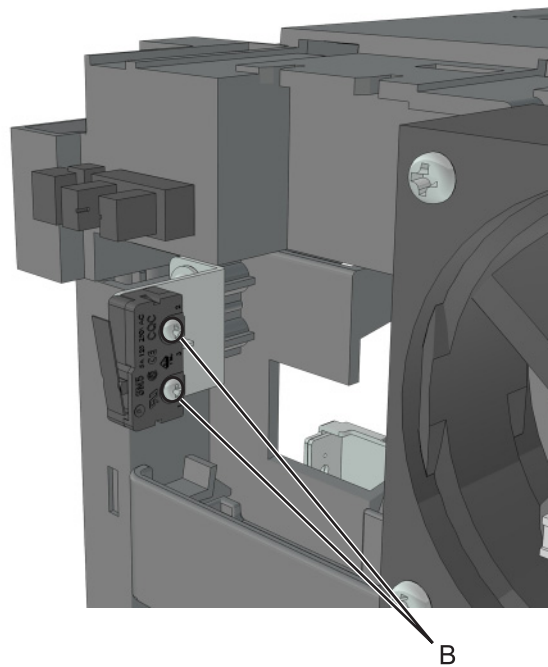

Stapler cooling fan removal

- 1 Remove the stapler right cover. See [“Stapler right cover removal” on page 424.](#)
- 2 Remove the stapler left cover. See [“Stapler left cover removal” on page 425.](#)
- 3 Remove the stapler rear cover. See [“Stapler rear cover removal” on page 433.](#)
- 4 Remove the stapler service cover. See [“Stapler service cover removal” on page 437.](#)
- 5 Disconnect the cooling fan cable CN8 from the controller card.
- 6 Remove the four screws (A) from the cooling fan.

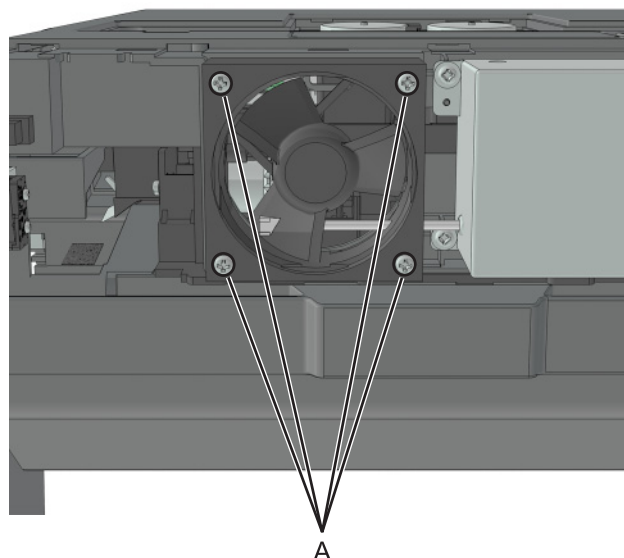

- 7 Route the cable off the stapler, and remove the cooling fan.

Note: Pay attention to the original routing of the cable.

Stapler power supply unit removal

- 1 Remove the stapler right cover. See [“Stapler right cover removal” on page 424.](#)
- 2 Remove the stapler left cover. See [“Stapler left cover removal” on page 425.](#)
- 3 Remove the stapler rear cover. See [“Stapler rear cover removal” on page 433.](#)
- 4 Remove the stapler cooling fan. See [“Stapler cooling fan removal” on page 441.](#)
- 5 Remove the stapler service cover.
- 6 Disconnect the power supply cable CN5 from the controller card.

7 Remove the four screws (A) from the power supply unit.

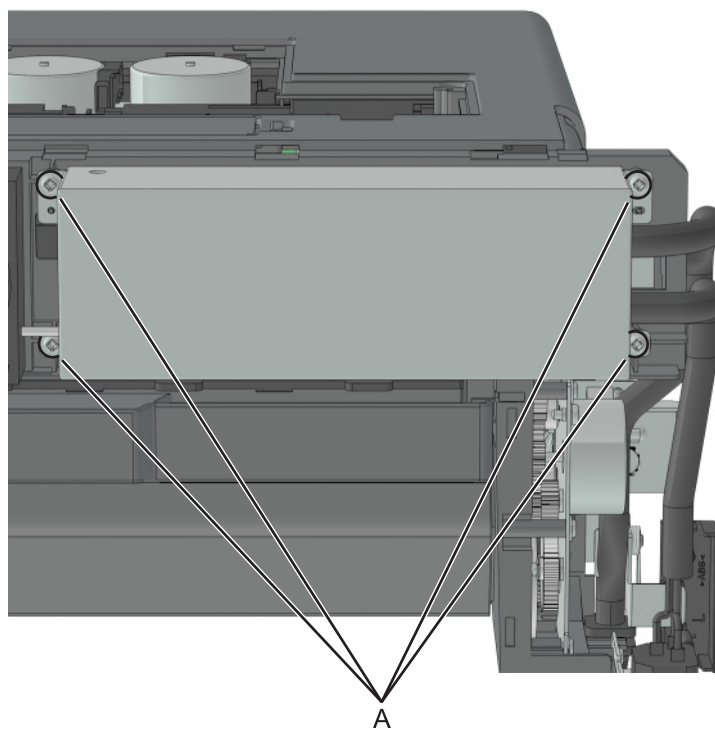

8 Remove the two screws (B) securing the power cable.

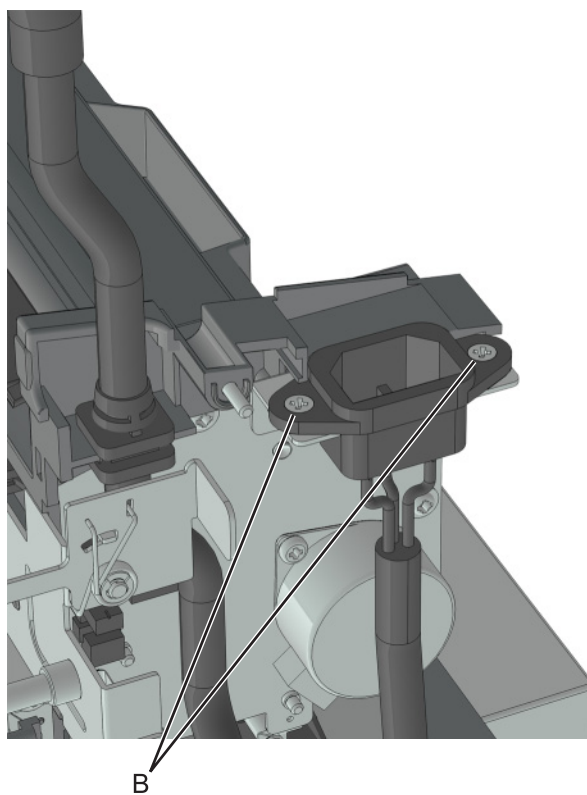

Parts removal

- 9 Cut the cable ties (C) securing the power cable to the stapler.

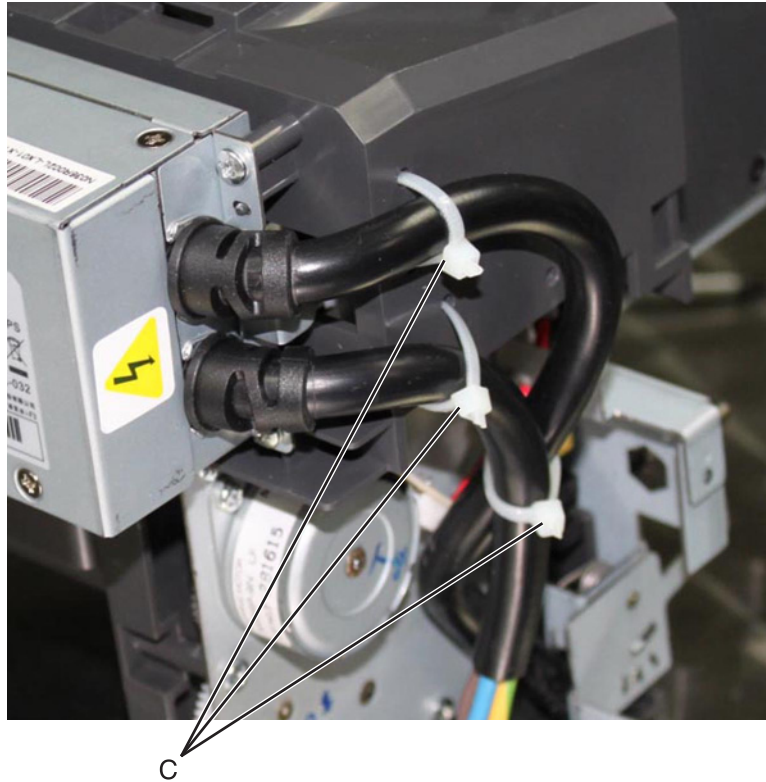

- 10 Route the cable off the stapler, and remove the power supply unit.

Note: Pay attention to the original position of the cable.

Stapler interface cable removal

- 1 Remove the stapler service cover. See [“Stapler service cover removal” on page 437](#).
- 2 Disconnect the interface cable CN15 from the controller card.

- 3 Flex the media access door to release the tab (A), then remove.

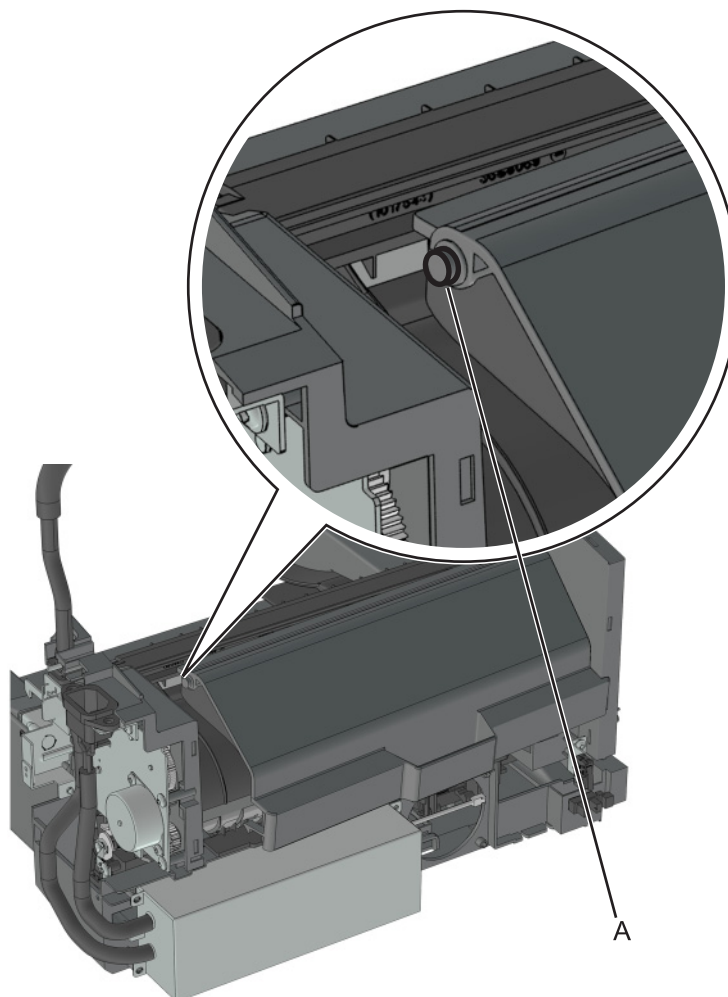

- 4 Using a flat-blade screwdriver, release the latches, then remove the input cover.

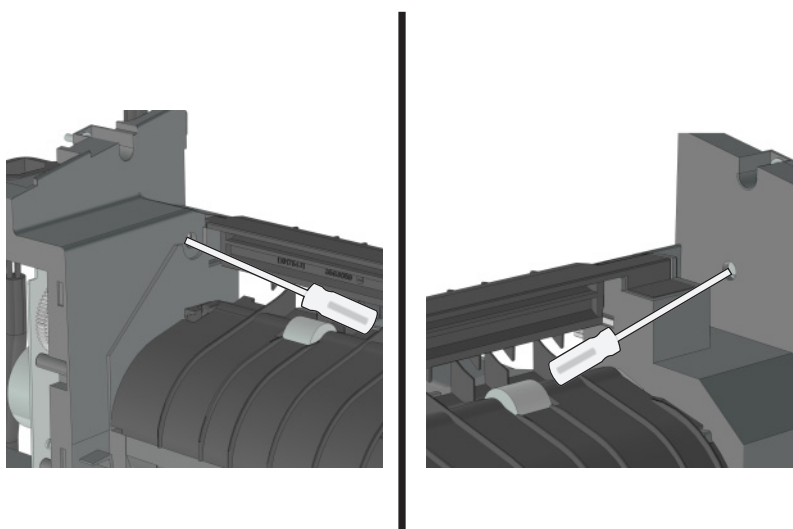

- 5 Squeeze the latches to release, and dislodge the interface cable from its slot.

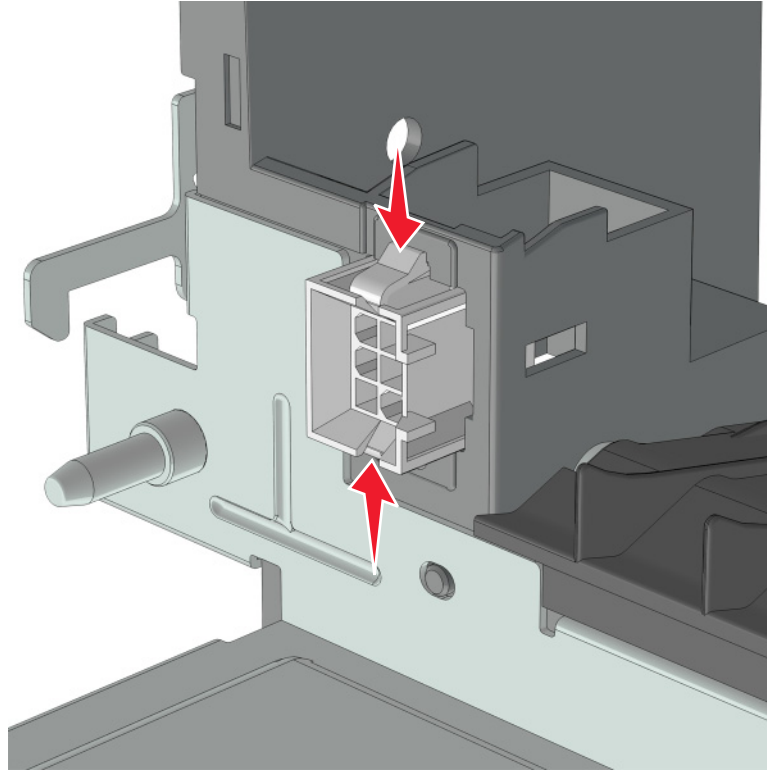

- 6 Route the cable off the stapler, and remove.

Note: Pay attention to the original routing of the cable.

Stapler top cover removal

- 1 Remove the right cover. See [“Stapler right cover removal” on page 424.](#)
- 2 Remove the left cover. See [“Stapler left cover removal” on page 425.](#)
- 3 Remove the rear cover. See [“Stapler rear cover removal” on page 433.](#)
- 4 Remove the stapler cooling fan. See [“Stapler cooling fan removal” on page 441.](#)
- 5 Remove the stapler power supply unit. See [“Stapler power supply unit removal” on page 441.](#)

- 6 Remove the two screws (A) from the top of the cover.

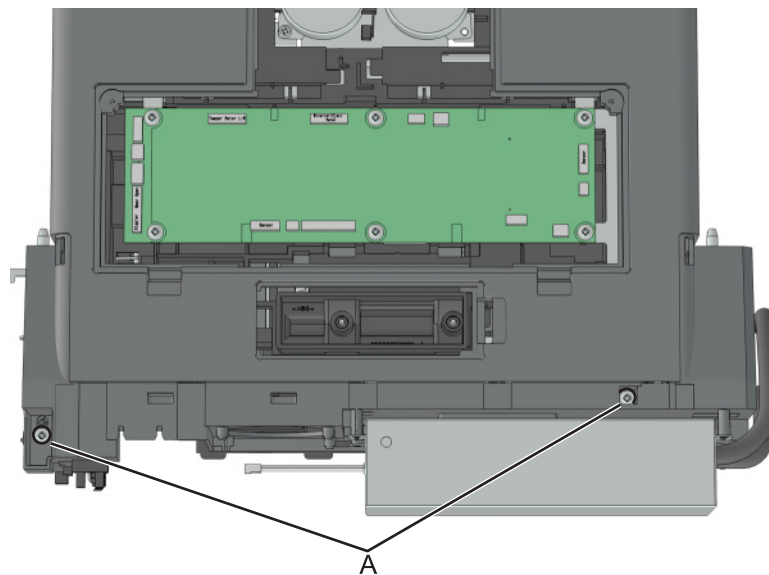

- 7 Remove the two screws (B) under the cover.

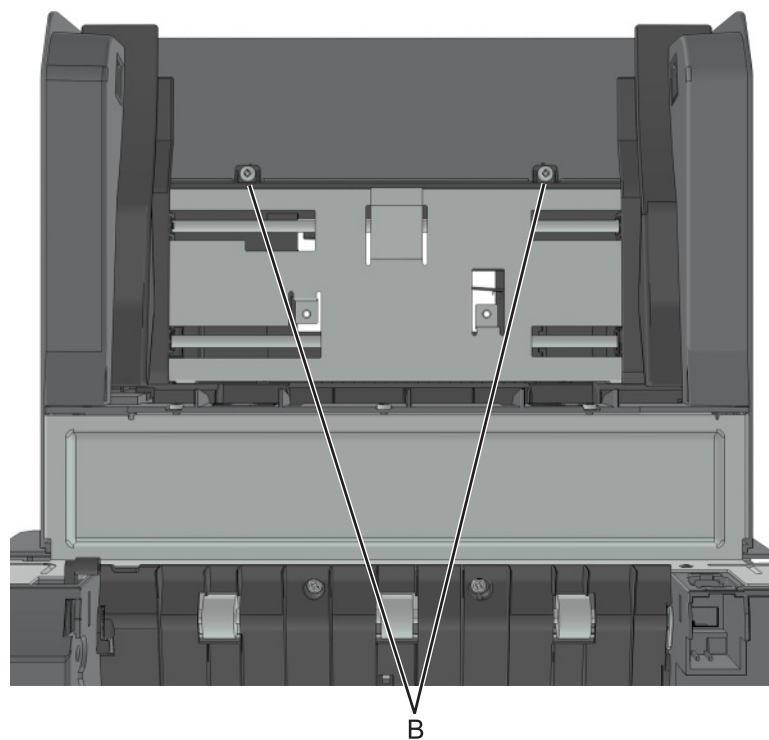

- 8 Remove the four screws (C) from the left side of the cover.

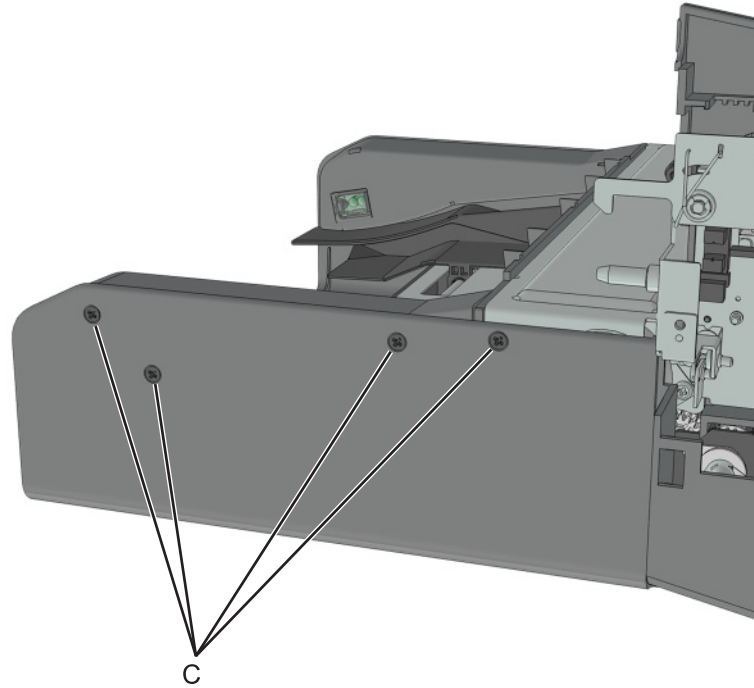

- 9 Remove the four screws (D) from the right side of the cover.

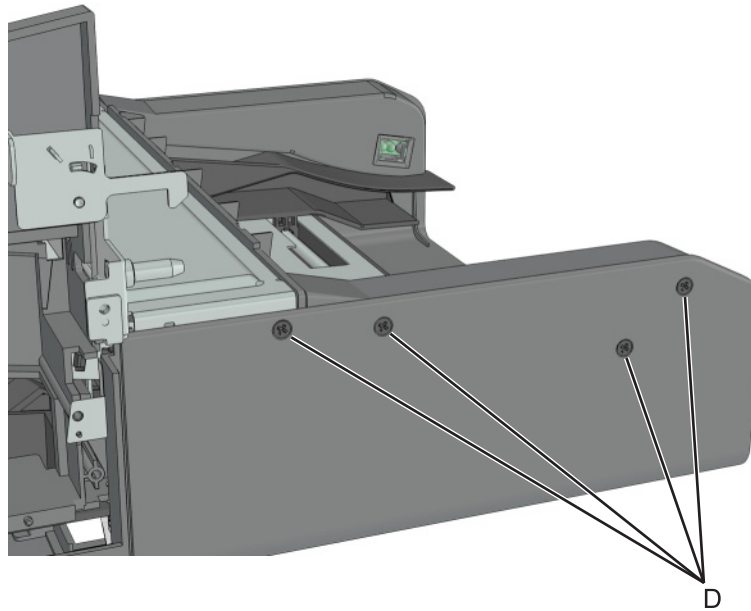

- 10 Lift the cover, then release the cables routed through the top cover.

Note: Pay attention to the original routing of the cables.

- 11 Remove the top cover.

Sensor (stapler bin full receive) removal

- 1 Remove the right cover. See [“Stapler right cover removal” on page 424.](#)
- 2 Remove the left cover. See [“Stapler left cover removal” on page 425.](#)
- 3 Remove the rear cover. See [“Stapler rear cover removal” on page 433.](#)
- 4 Remove the stapler service cover. See [“Stapler service cover removal” on page 437.](#)
- 5 Disconnect the sensor cable CN18 from the controller card.
- 6 Remove the two screws (A) from the top cover.

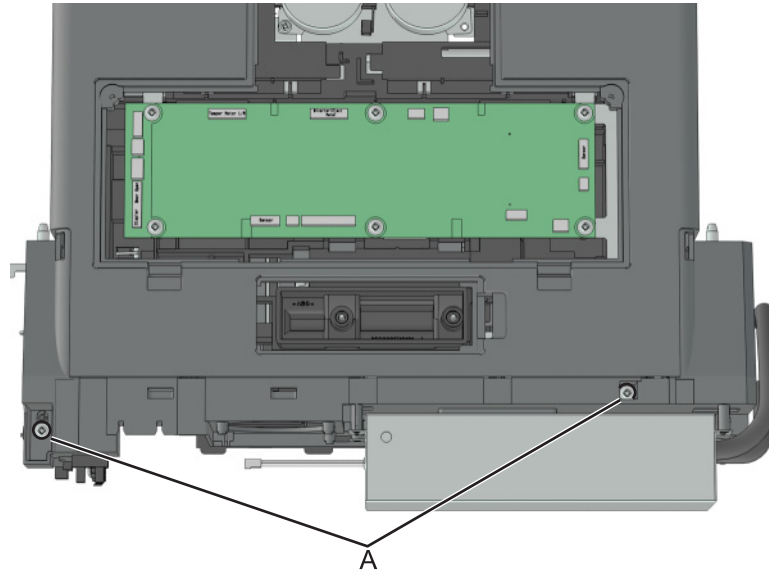

- 7** Remove the two screws (B) under the cover.

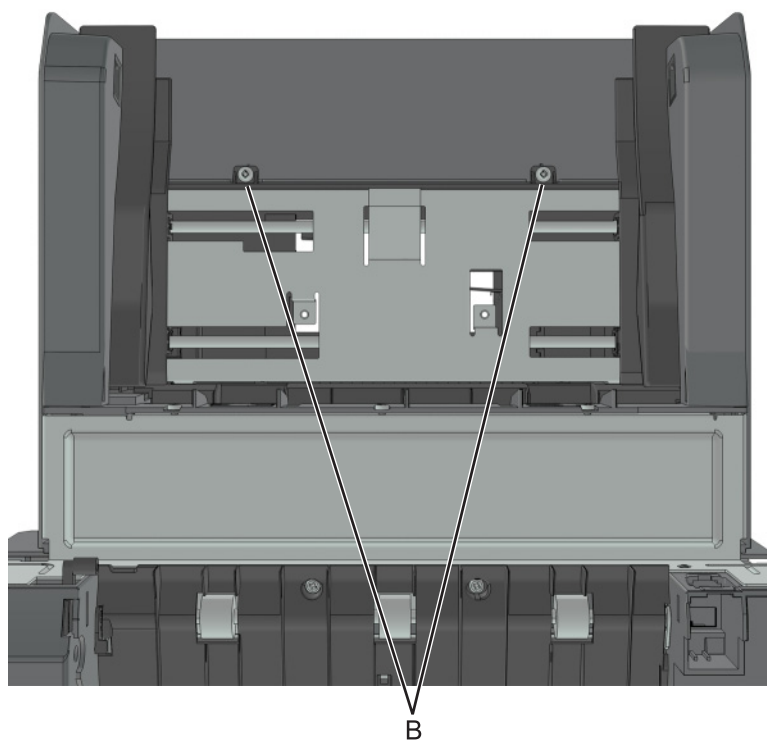

- 8** Remove the four screws (C) from the left side of the cover.

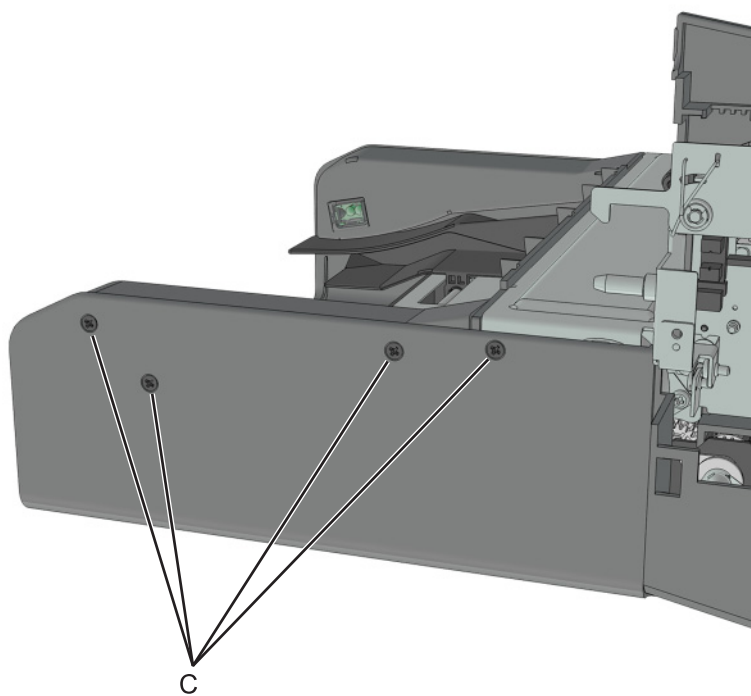

- 9** To access the sensor, release the sensor cover from the left side of the top cover.

- 10** Remove the two screws (D) securing the sensor.

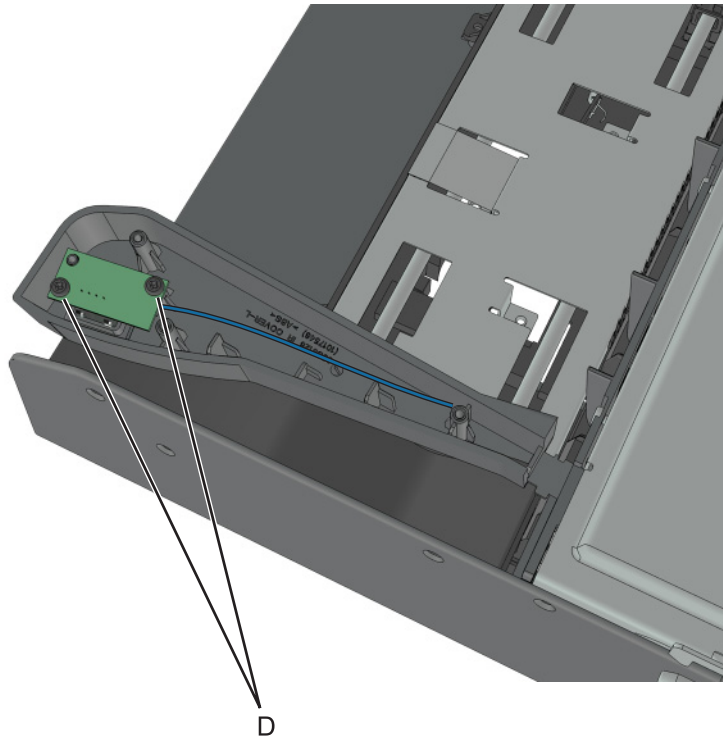

- 11** Route the sensor cable off the stapler, then remove the sensor.

Note: Pay attention to the original routing of the cables.

Sensor (stapler bin full send) removal

- 1 Remove the right cover. See [“Stapler right cover removal” on page 424.](#)
- 2 Remove the left cover. See [“Stapler left cover removal” on page 425.](#)
- 3 Remove the rear cover. See [“Stapler rear cover removal” on page 433.](#)
- 4 Remove the stapler service cover. See [“Stapler service cover removal” on page 437.](#)
- 5 Disconnect the sensor cable CN12 from the controller card.

- 6 Remove the two screws (A) from the top cover.

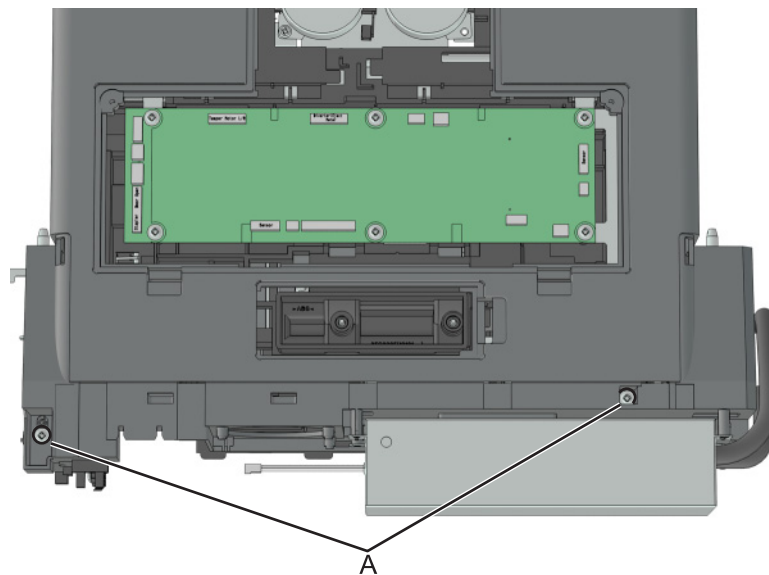

- 7 Remove the two screws (B) under the cover.

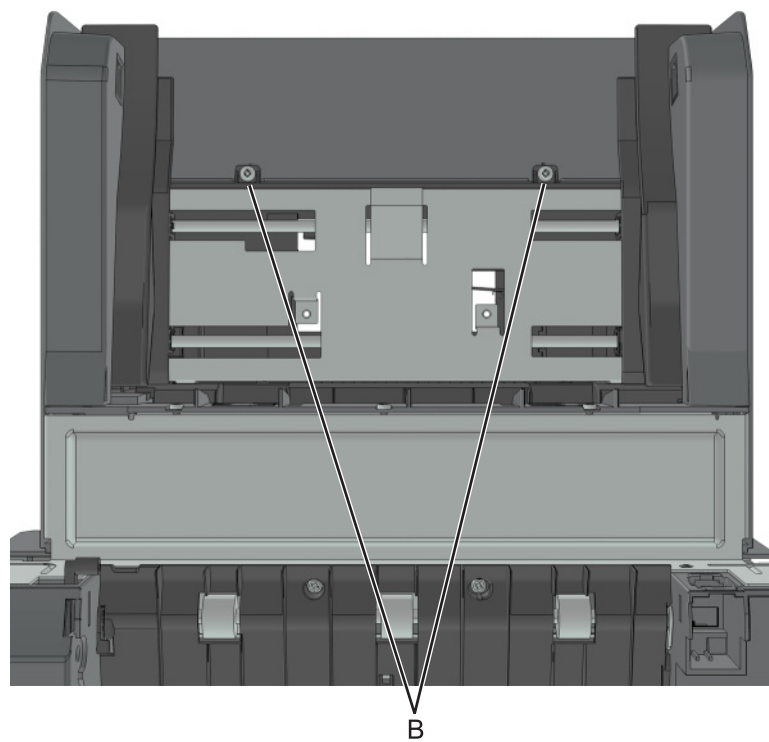

- 8 Remove the four screws (C) from the right side of the cover.

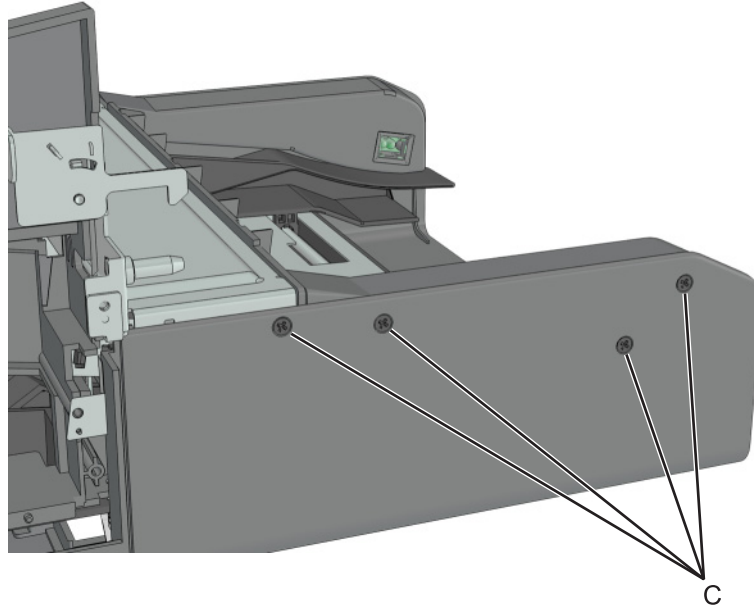

- 9 To access the sensor, release the sensor cover from the right side of the top cover.

- 10 Remove the two screws (D) securing the sensor.

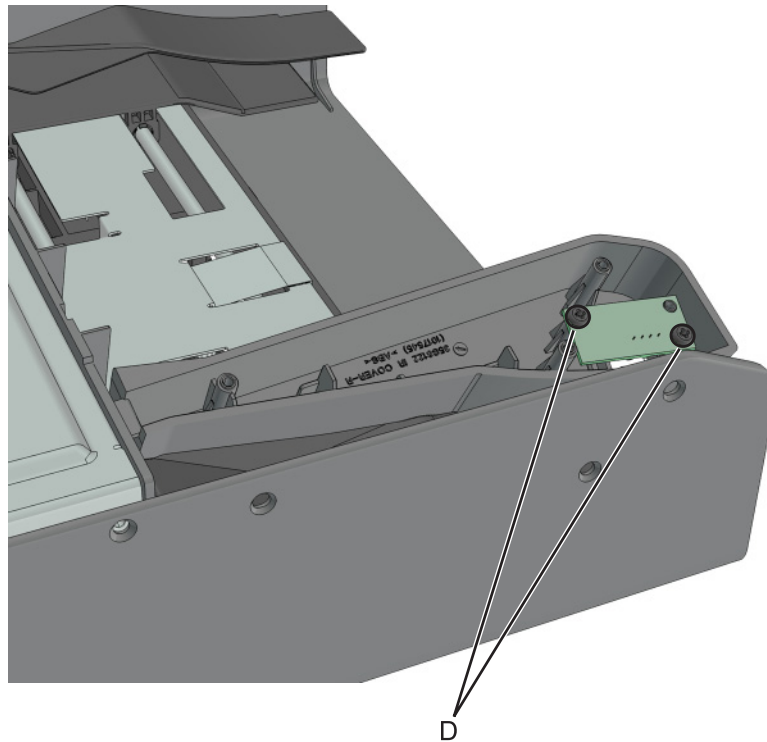

- 11 Route the sensor cable off the stapler, then remove the sensor.

Note: Pay attention to the original routing of the cables.

Sensor (stapler pass through) removal

- 1 Flex the media access door to release the tab (A), then remove.

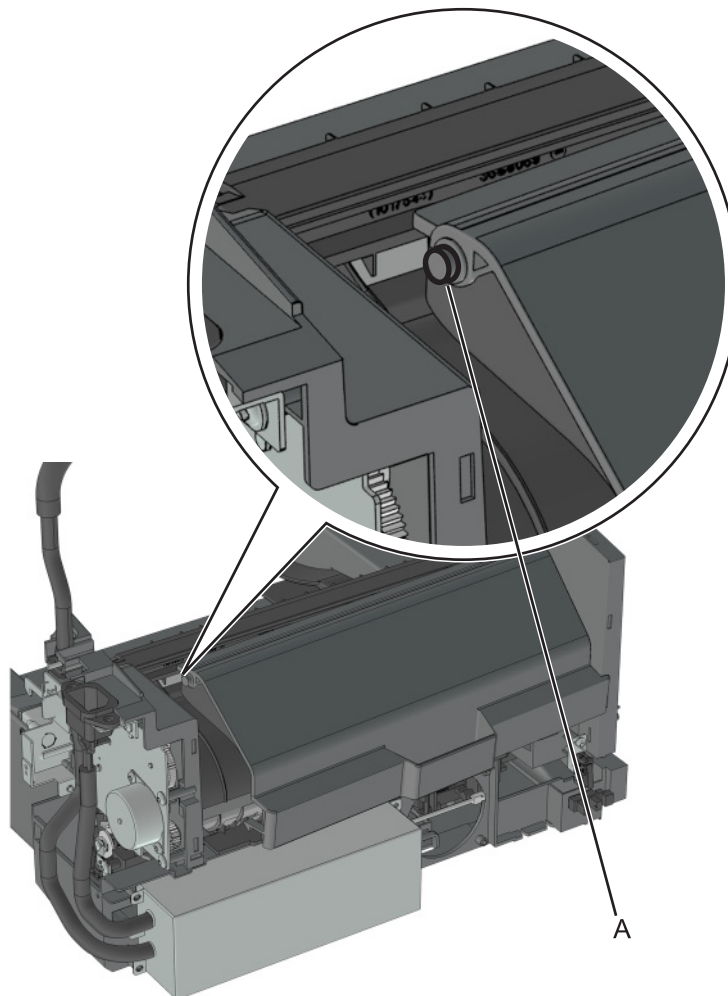

- 2 Using a flat-blade screwdriver, release the latches, then remove the input cover.

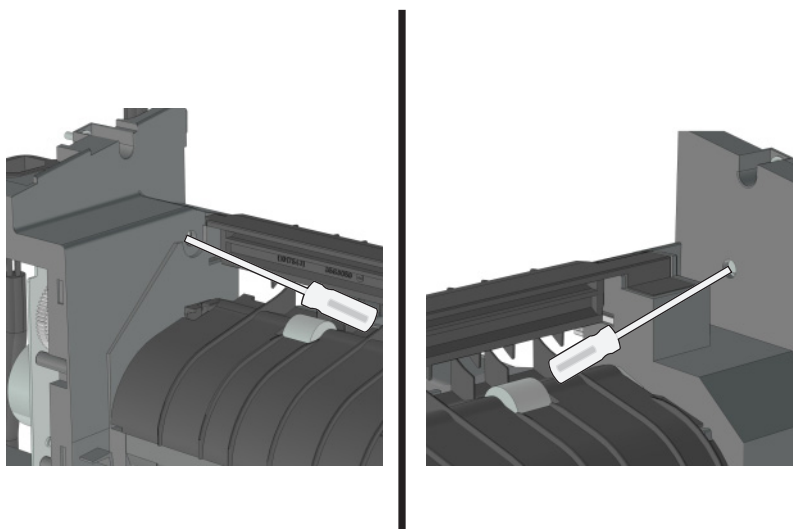

Parts removal

- 3 Remove the two screws (B) from the media input frame.

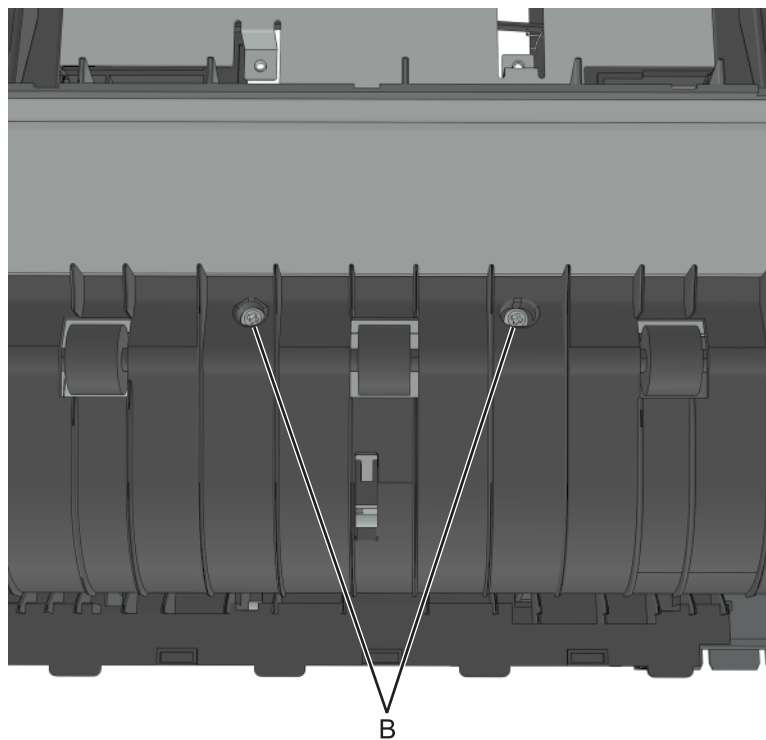

- 4 Remove the screw (C) securing the sensor.

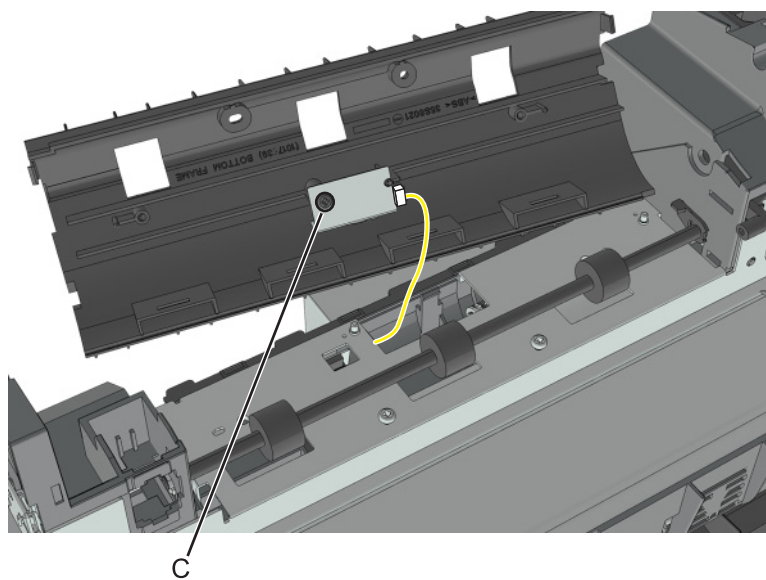

- 5 Disconnect the cable (D) from the sensor.

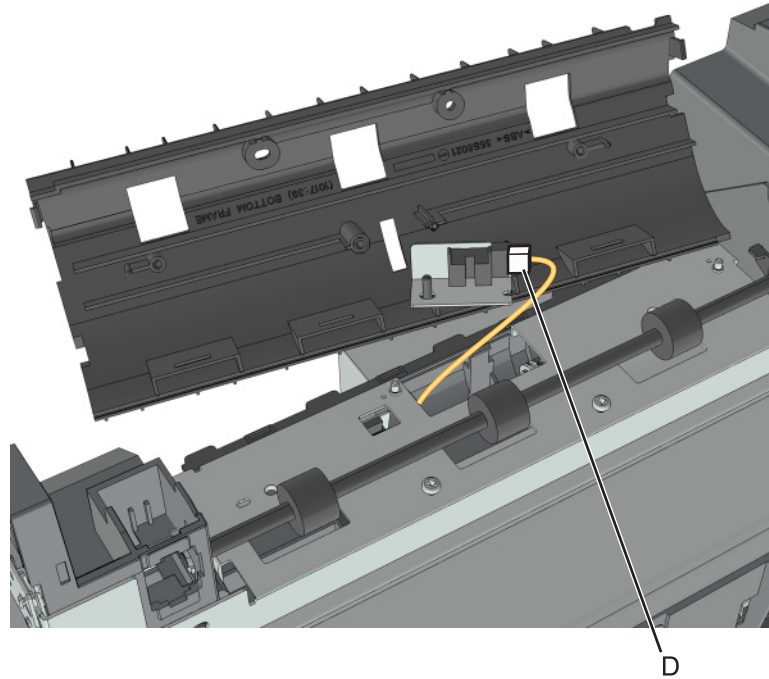

- 6 Release the latches, and then remove the sensor.

Tamper main assembly removal

- 1 Remove the stapler right cover. See [“Stapler right cover removal” on page 424.](#)
- 2 Remove the stapler left cover. See [“Stapler left cover removal” on page 425.](#)
- 3 Remove the stapler rear cover. See [“Stapler rear cover removal” on page 433.](#)
- 4 Remove the stapler service cover. See [“Stapler service cover removal” on page 437.](#)
- 5 Remove the stapler controller card. See [“Stapler controller card removal” on page 437.](#)
- 6 Remove the stapler cooling fan. See [“Stapler cooling fan removal” on page 441.](#)
- 7 Remove the stapler power supply unit. See [“Stapler power supply unit removal” on page 441.](#)
- 8 Remove the stapler top cover. See [“Stapler top cover removal” on page 445.](#)

- 9 Remove the five screws (A), and then remove the tamper main assembly.

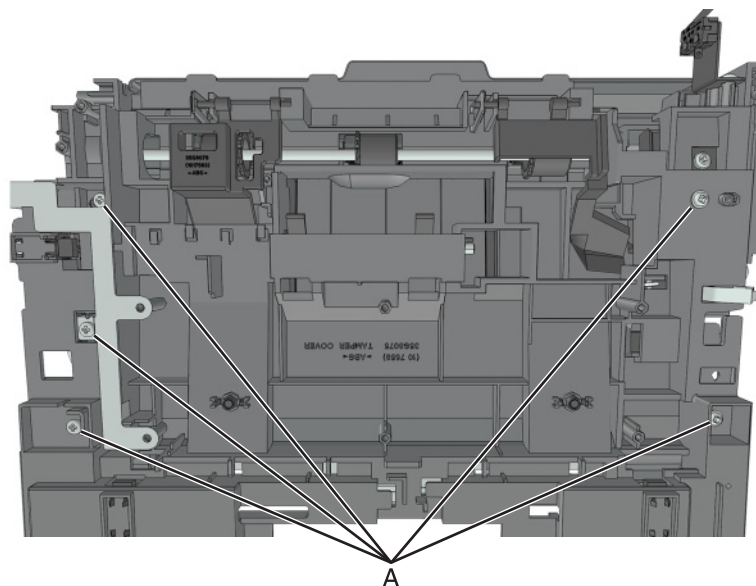

Tamper sub-assembly removal

- 1 Remove the stapler right cover. See [“Stapler right cover removal” on page 424.](#)
- 2 Remove the stapler left cover. See [“Stapler left cover removal” on page 425.](#)
- 3 Remove the stapler rear cover. See [“Stapler rear cover removal” on page 433.](#)
- 4 Remove the stapler service cover. See [“Stapler service cover removal” on page 437.](#)
- 5 Remove the stapler controller card. See [“Stapler controller card removal” on page 437.](#)
- 6 Remove the stapler cooling fan. See [“Stapler cooling fan removal” on page 441.](#)
- 7 Remove the stapler power supply unit. See [“Stapler power supply unit removal” on page 441.](#)
- 8 Remove the stapler top cover. See [“Stapler top cover removal” on page 445.](#)
- 9 Remove the tamper main assembly. See [“Tamper main assembly removal” on page 455.](#)

10 Disconnect the tamper motor cables (A).

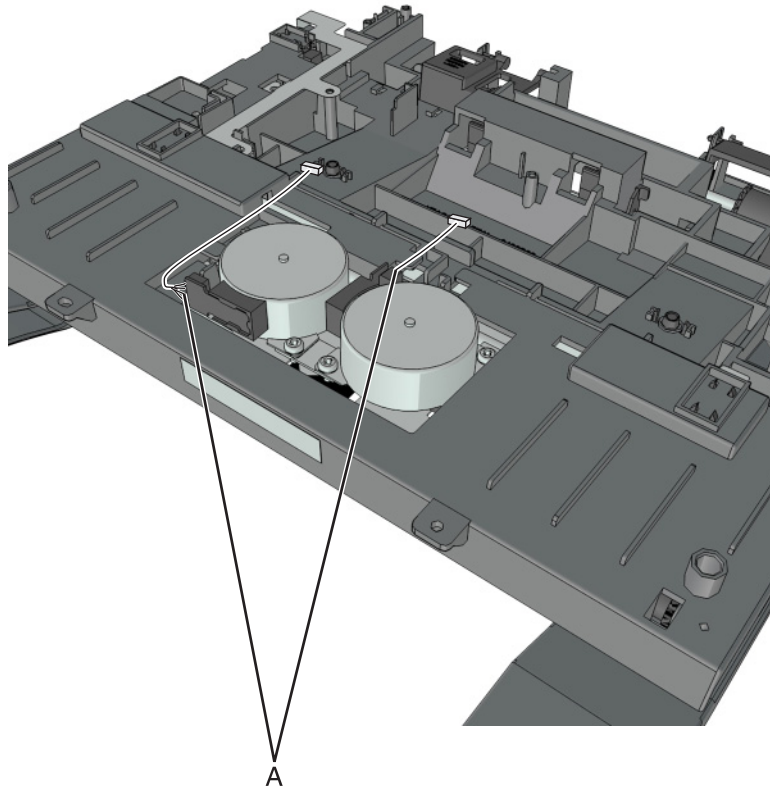

11 Move the tampers inward to access the screws (B) at the bottom.

- 12** Remove the four screws (B), and then remove the sub-assembly.

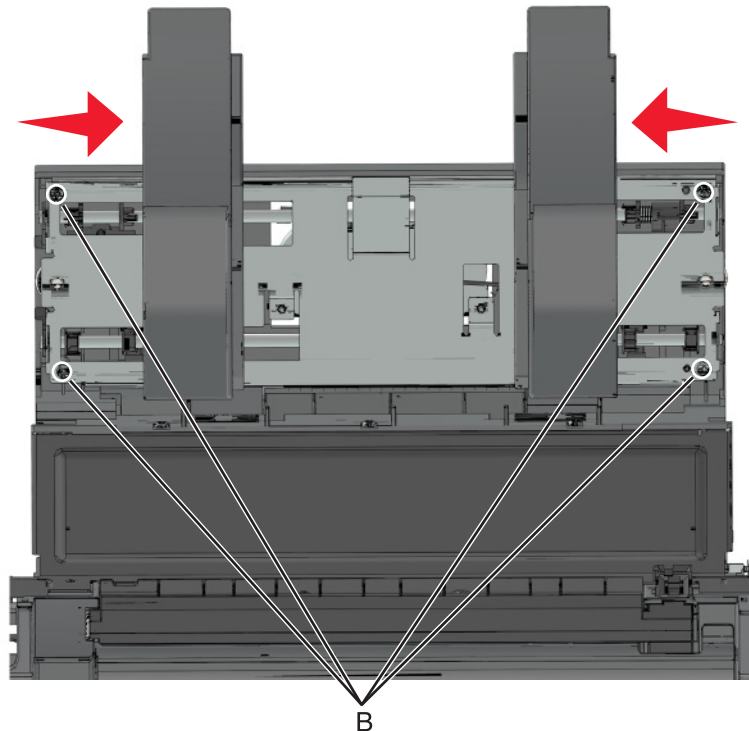

Tamper drive belt removal

- 1** Remove the stapler right cover. See [“Stapler right cover removal” on page 424.](#)
- 2** Remove the stapler left cover. See [“Stapler left cover removal” on page 425.](#)
- 3** Remove the stapler rear cover. See [“Stapler rear cover removal” on page 433.](#)
- 4** Remove the stapler service cover. See [“Stapler service cover removal” on page 437.](#)
- 5** Remove the stapler controller card. See [“Stapler controller card removal” on page 437.](#)
- 6** Remove the stapler cooling fan. See [“Stapler cooling fan removal” on page 441.](#)
- 7** Remove the stapler power supply unit. See [“Stapler power supply unit removal” on page 441.](#)
- 8** Remove the stapler top cover. See [“Stapler top cover removal” on page 445.](#)
- 9** Remove the tamper main assembly. See [“Tamper main assembly removal” on page 455.](#)
- 10** Remove the tamper sub-assembly. See [“Tamper sub-assembly removal” on page 456.](#)
- 11** Remove the tamper motors. See [“Stapler left tamper motor removal” on page 437](#) and [“Stapler right tamper motor removal” on page 438.](#)

- 12 Remove the tamper drive belts (A).

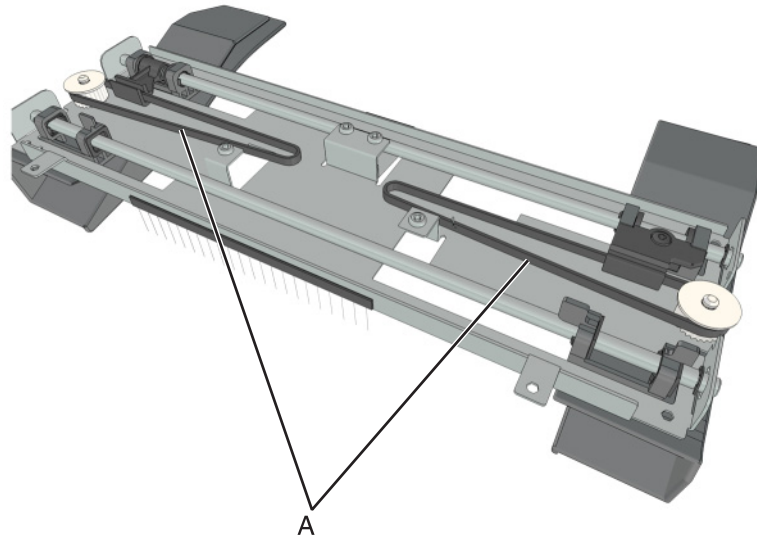

Diverter gearbox removal

- 1 Remove the stapler right cover. See [“Stapler right cover removal” on page 424.](#)
- 2 Remove the stapler carriage assembly. See [“Stapler carriage assembly removal” on page 427.](#)
- 3 Remove the stapler left cover. See [“Stapler left cover removal” on page 425.](#)
- 4 Remove the stapler rear cover. See [“Stapler rear cover removal” on page 433.](#)

- 5 Remove the two screws (A), and cut the cable ties securing the power supply cable.

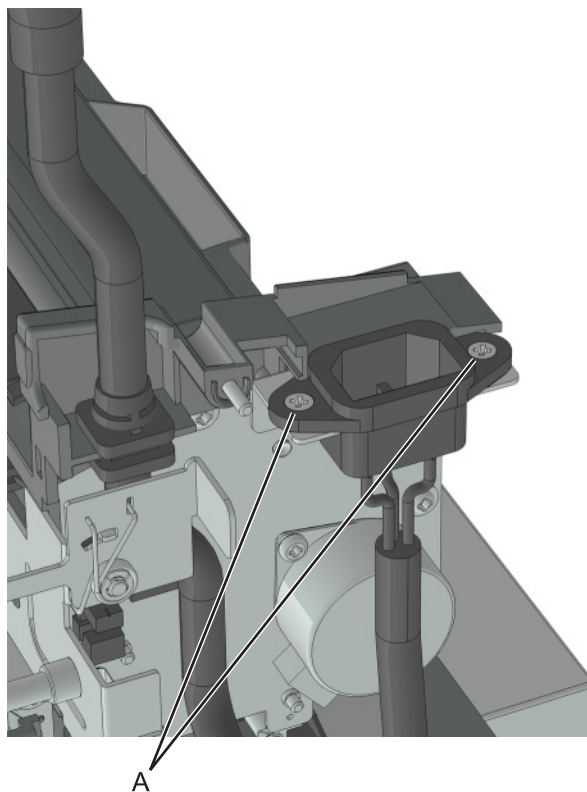

- 6 Move the power supply cable out of the way, and then disconnect the sensor and motor cables (B).

7 Remove the five screws (C) from the diverter motor assembly.

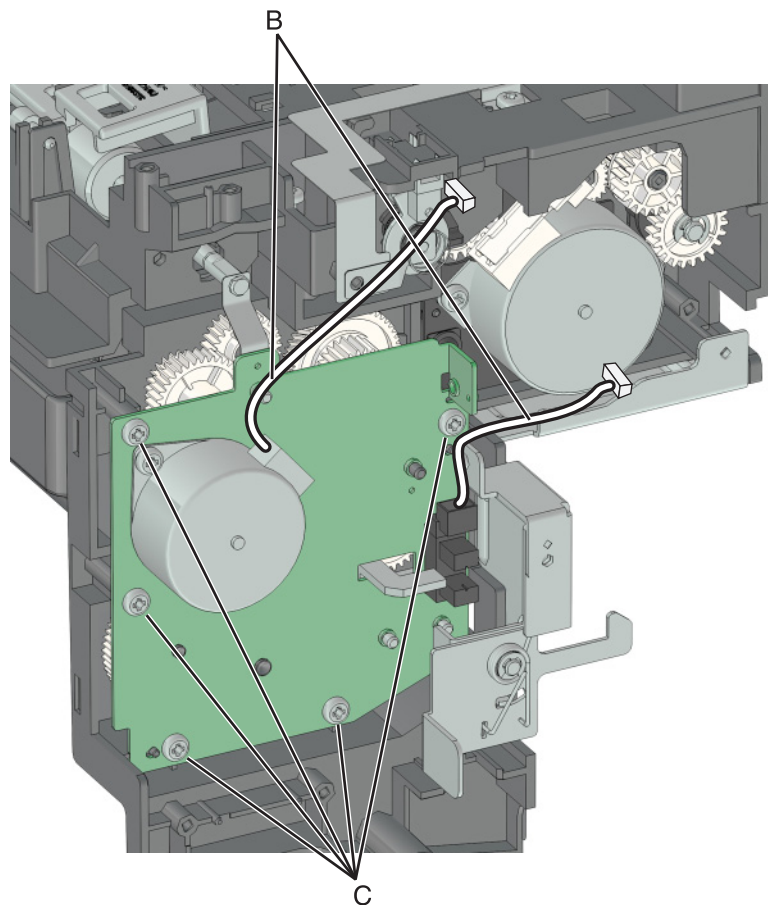

8 Release the E-clip (D) securing the lowermost gear. Pull the gears off their shafts to remove them.

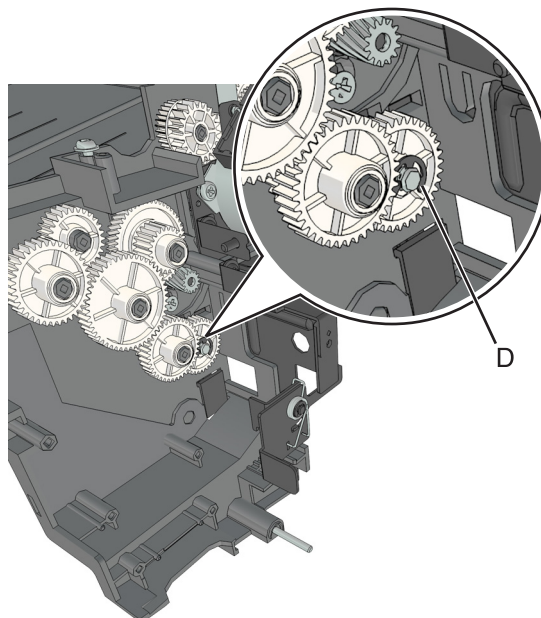

Stapler accumulator assembly removal

- 1 Remove the stapler right cover. See [“Stapler right cover removal” on page 424.](#)
- 2 Remove the stapler left cover. See [“Stapler left cover removal” on page 425.](#)
- 3 Remove the stapler rear cover. See [“Stapler rear cover removal” on page 433.](#)
- 4 Remove the stapler rear door. See [“Stapler rear door removal” on page 426.](#)
- 5 Remove the stapler service cover. See [“Stapler service cover removal” on page 437.](#)
- 6 Remove the stapler controller card. See [“Stapler controller card removal” on page 437.](#)
- 7 Remove the stapler cooling fan. See [“Stapler cooling fan removal” on page 441.](#)
- 8 Remove the stapler power supply unit. See [“Stapler power supply unit removal” on page 441.](#)
- 9 Remove the stapler top cover. See [“Stapler top cover removal” on page 445.](#)
- 10 Remove the tamper main assembly. See [“Tamper main assembly removal” on page 455.](#)
The accumulator assembly remains.

Sensor (stapler right tamper HP) removal

- 1 Remove the stapler right cover. See [“Stapler right cover removal” on page 424.](#)
- 2 Remove the stapler left cover. See [“Stapler left cover removal” on page 425.](#)
- 3 Remove the stapler rear cover. See [“Stapler rear cover removal” on page 433.](#)
- 4 Remove the stapler service cover. See [“Stapler service cover removal” on page 437.](#)
- 5 Remove the stapler controller card. See [“Stapler controller card removal” on page 437.](#)
- 6 Remove the stapler cooling fan. See [“Stapler cooling fan removal” on page 441.](#)
- 7 Remove the stapler power supply unit. See [“Stapler power supply unit removal” on page 441.](#)
- 8 Remove the stapler top cover. See [“Stapler top cover removal” on page 445.](#)
- 9 Remove the tamper main assembly. See [“Tamper main assembly removal” on page 455.](#)
- 10 Remove the tamper sub-assembly. See [“Tamper sub-assembly removal” on page 456.](#)

- 11 Disconnect the sensor cable (A). Release the latches, and then remove the sensor.

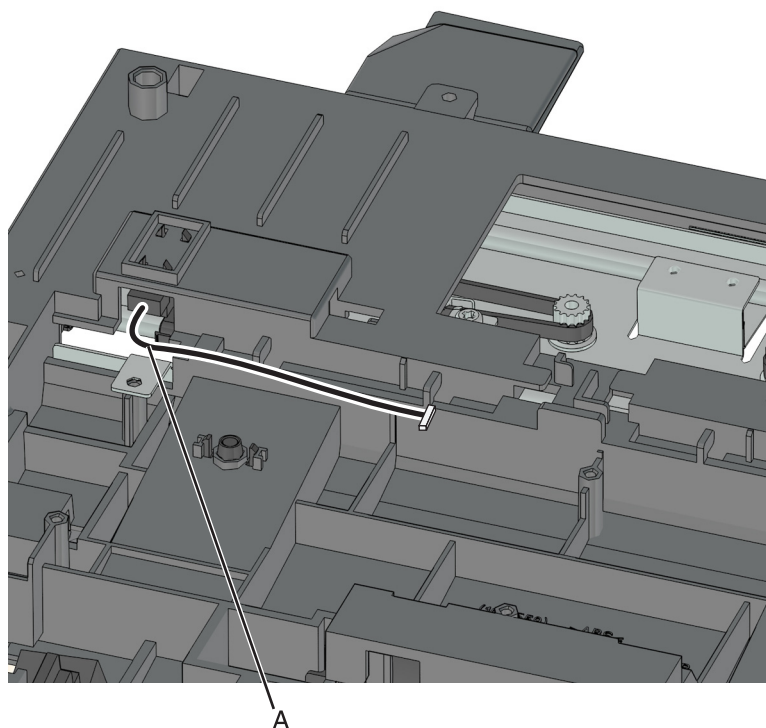

Sensor (stapler left tamper HP) removal

- 1 Remove the stapler right cover. See [“Stapler right cover removal” on page 424.](#)
- 2 Remove the stapler left cover. See [“Stapler left cover removal” on page 425.](#)
- 3 Remove the stapler rear cover. See [“Stapler rear cover removal” on page 433.](#)
- 4 Remove the stapler service cover. See [“Stapler service cover removal” on page 437.](#)
- 5 Remove the stapler controller card. See [“Stapler controller card removal” on page 437.](#)
- 6 Remove the stapler cooling fan. See [“Stapler cooling fan removal” on page 441.](#)
- 7 Remove the stapler power supply unit. See [“Stapler power supply unit removal” on page 441.](#)
- 8 Remove the stapler top cover. See [“Stapler top cover removal” on page 445.](#)
- 9 Remove the tamper main assembly. See [“Tamper main assembly removal” on page 455.](#)
- 10 Remove the tamper sub-assembly. See [“Tamper sub-assembly removal” on page 456.](#)

- 11** Disconnect the sensor cable (A). Release the latches, and then remove the sensor.

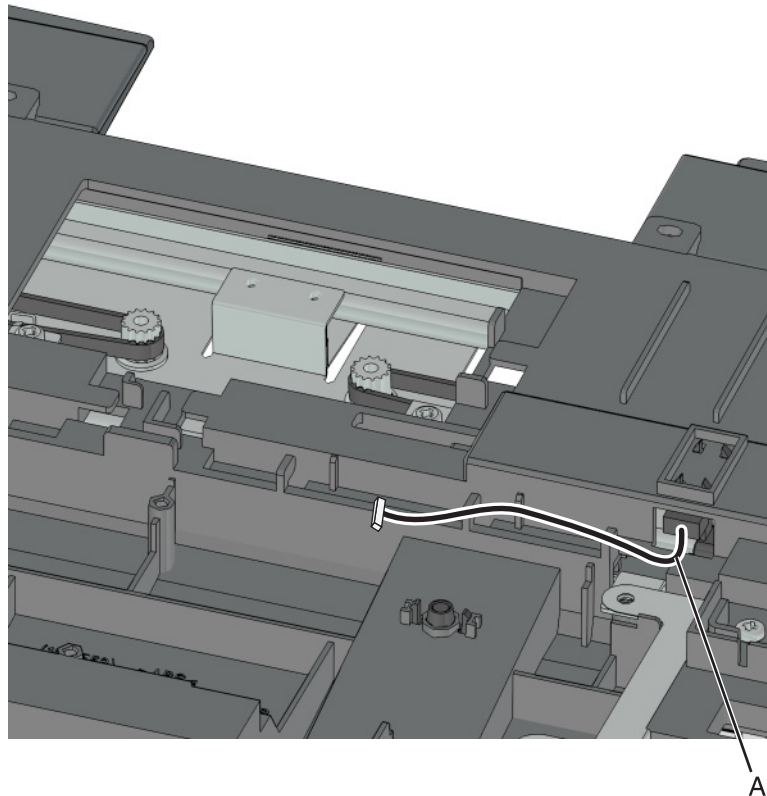

Sensor (stapler paddle HP) removal

- 1** Remove the stapler right cover. See [“Stapler right cover removal” on page 424.](#)
- 2** Remove the stapler left cover. See [“Stapler left cover removal” on page 425.](#)
- 3** Remove the stapler rear cover. See [“Stapler rear cover removal” on page 433.](#)
- 4** Remove the stapler service cover. See [“Stapler service cover removal” on page 437.](#)
- 5** Remove the stapler controller card. See [“Stapler controller card removal” on page 437.](#)
- 6** Remove the stapler cooling fan. See [“Stapler cooling fan removal” on page 441.](#)
- 7** Remove the stapler power supply unit. See [“Stapler power supply unit removal” on page 441.](#)
- 8** Remove the stapler top cover. See [“Stapler top cover removal” on page 445.](#)

- 9 Disconnect the sensor cable (A). Release the latches, and then remove the sensor.

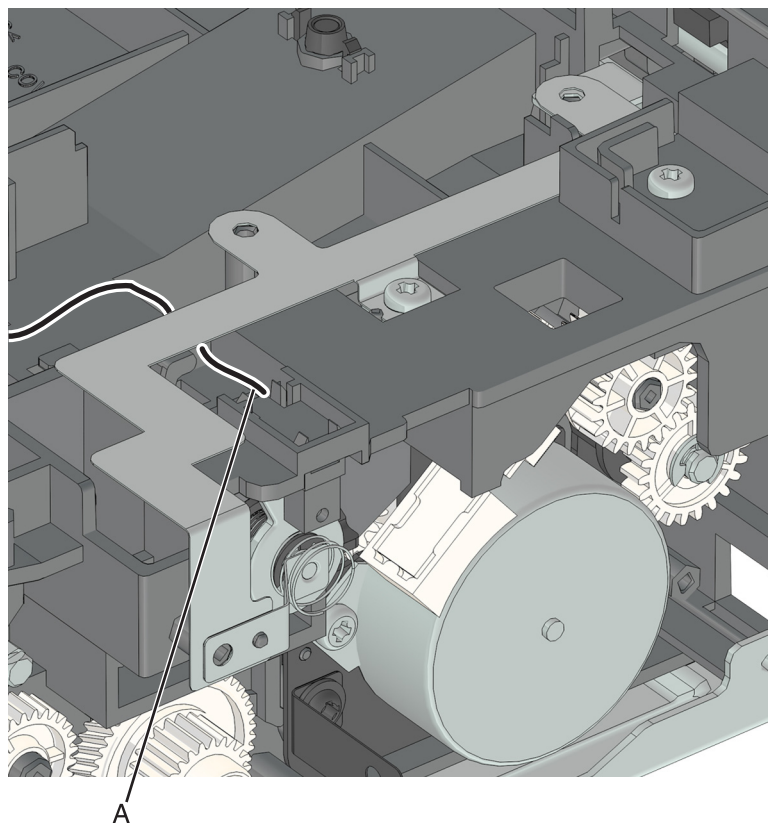

Component locations

Exterior locations

Front view

Basic model

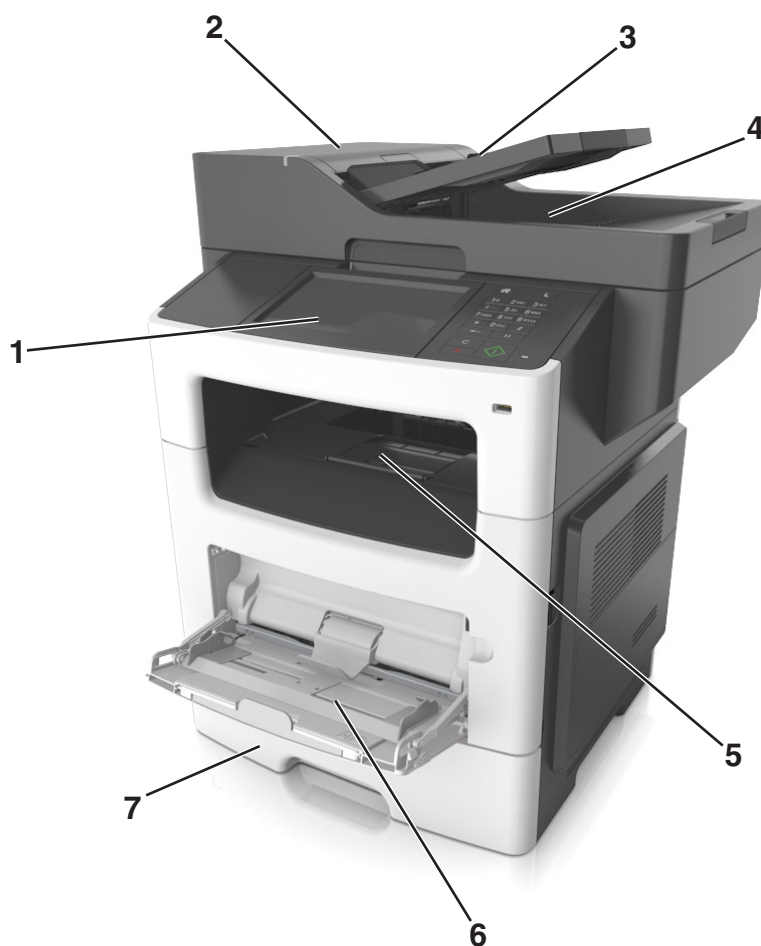

1	Display
2	Automatic document feeder (ADF)
3	ADF tray
4	ADF bin
5	Standard bin
6	Multipurpose feeder
7	Standard 550-sheet tray

Configured model



1	Optional 250-sheet tray
2	Optional 550-sheet tray
3	Optional stapler

Rear view

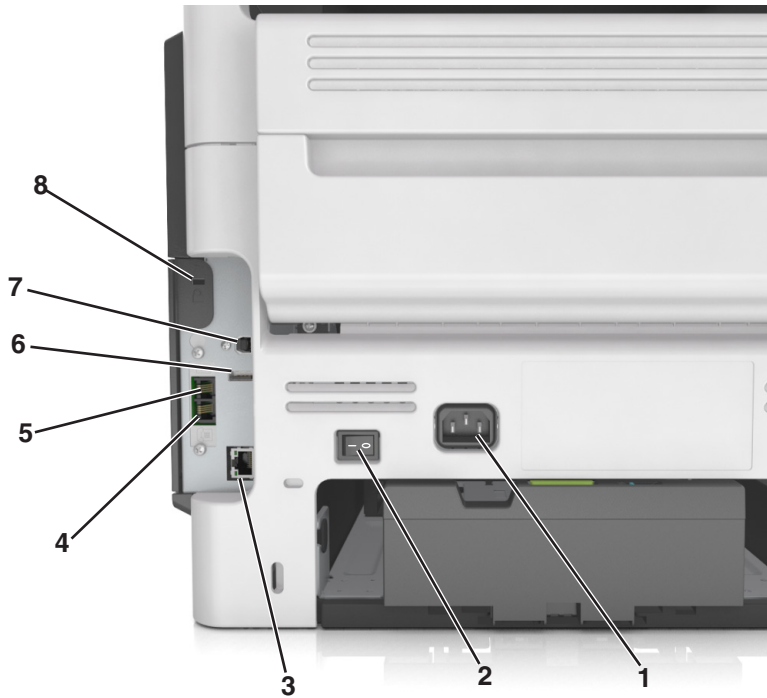

Component locations

Connector	Connects to	Pin no.	Signal
J10	Duplex solenoid	1	+24V
		2	V_DPRSOL
J2	Ethernet outlet	N/A	Ethernet connection—can't be probed
J24	MPF solenoid	1	V_MPT+
		2	V_MPT-

Connector	Connects to	Pin no.	Signal
J30	CCD module	1	FBR_LAMP_ON
		2	GND
		3	V24_14V_FB_CDU
		4	V24_14V_FB_CDU
		5	GND
		6	V24_5V_FB_CDU
		7	V24_5V_FB_CDU
		8	FB_POWER_SAVER
		9	GND
		10	FBR_AFE_SEN
		11	FBR_AFE_SCK
		12	FBR_AFE_SDIO
		13	GND
		14	FBR_AFE_SH
		15	GND
		16	FB_LVDS_RXIN0+
		17	FB_LVDS_RXIN0-
		18	GND
		19	FB_LVDS_RXIN1+
		20	FB_LVDS_RXIN1-
		21	GND
		22	FB_LVDS_RXIN2+
		23	FB_LVDS_RXIN2-
		24	GND
		25	FB_LVDS_RXCLK+
		26	FB_LVDS_RXCLK-
		27	GND
		28	FB_LVDS_MCLK+
		29	FB_LVDS_MCLK-
		30	GND

Connector	Connects to	Pin no.	Signal
J43	Thumb drive front USB host (mini type)	1	M1
		2	USB_DM1
		3	USB_DP1
		4	
		5	GND
J44	Sensor (cover interlock)	1	V24_33V_LD
		2	+5V_OPEN
		3	GND
J47	Back USB host port (type A, tall, narrow)	1	VBUSB
		2	SUB_DM2
		3	USB_DP2
		4	GND
J6	LSU, drive and H sync	1	PH_TH_0
		2	V24_33v_LD
		3	PH_TH_1N
		4	GND
		5	V12_DRIVE_OUT0
		6	GND
		7	V12_DRIVE_OUT1
JACM1	Sensor (ACM)	1	+5V_ENG_SW
		2	S_ACM_SEN_C
		3	GND

Connector	Connects to	Pin no.	Signal
JADF1	ADF	1	PAP_PRES_ADFR
		2	FEED_DIR_ADFR
		3	STAGE_ADFR
		4	FEED_PWM_ADFR
		5	FEED_ADFR
		6	VREF_ADFR
		7	DUPLEX_ADFR
		8	PICK_DIR_ADFR
		9	COVER_FBR
		10	PICK_PWM_ADFR
		11	COVER_ADFR
		12	NFAULT_8812_ADFR
		13	SKEW_ADFR
		14	+24V_ADF
		15	+3.3V_MAIN_ADF
		16	+24V_ADF
		17	GND
		18	GND
		19	PICK_ENC_X_ADFR
		20	FEED_EC_Y_ADFR
		21	FEED_EC_X_ADFR
		22	+3.3V_WAKE_ADF
		23	GND
		24	PICK_ENC_Y_ADFR
JBINS1	Sensor (bin full)	1	+3.3V_ENG_SW
		2	PAPER_FULL
		3	GND
		4	GND
JCART	Cartridge motor	1	V_5VCART
		2	S_CART_ENG_C
		3	GND
		4	V_CART_MP_C
		5	V_CART_MM_C

Connector	Connects to	Pin no.	Signal
JDUPP1	Sensor (duplex) Sensor (input)	1	V3.3V_DUPLEX
		2	S_DUPLEX_C
		3	GND
		4	V3.3V_PAPER_IN
		5	S_PAPER_IN_C
		6	GND
JEXIT1	Sensor (fuser exit)	1	V_3.3_PAPER_OUT
		2	S_PAPER_OUT_C
		3	GND
JFAN1	Cooling fan	1	GND
		2	FAN_HC
		3	FAN_FB
		4	GND
JFBM1	Flatbed motor	1	FBM_A-
		2	FBM_A+
		3	FBM_B+
		4	FBM_B-
JHOME	Sensor (flatbed home position)	1	+5v_HOME
		2	GND
		3	HOME_FBR
JINDEX1	Sensor (index)	1	V3.3_INDEX
		2	S_INDEX_C
		3	GND
JLIFT1	Lift motor	1	V_5VLIFT
		2	S_LIFT_ENC_C
		3	GND
		4	V_LP_MP_C
		5	V_LP_MM_C

Connector	Connects to	Pin no.	Signal
JLSU1	LSU, video	1	LDEN_C
		2	SHADE_C
		3	VDO_ADJ_C
		4	GND
		5	LPOWER_C
		6	BOOST_C
		7	GND
		8	VIDEO-_C
		9	VIDEO+_C
		10	GND
JMPFP1	Sensor (MPF)	1	+3.3_ENG_SW
		2	S_MPF_PP_C
		3	GND
JMTR1	Main motor	1	HALL_U_C
		2	HALL_V_C
		3	HALL_W_C
		4	FG_C
		5	GND
		6	+5_MOTFUSE
		7	V_C1_U
		8	V_C1_V
		9	V_C1_W
JOPT1	Options	1	VS24_FUSE_OPT
		2	J_OPT_TXR
		3	J_INPUT_FDT
		4	J_OPT_RXR
		5	GND
		6	VS24_OPT_5V
JPLEN1	Sensor (flatbed paper length)	1	GND
		2	LENGTH_FBR
		3	+5V_LENGTH

Connector	Connects to	Pin no.	Signal
JPS1	HVPS/LVPS	1	CHARGE_C
		2	SERVO_OUT_C
		3	DEV_C
		4	TXENABLE_C
		5	TX_C
		6	FUSER_RELAY
		7	HVPS_ON_C
		8	FUSER_ON_C
		9	ZEROX_C
		10	SHUTOFF_24V
		11	+5V_CONT
		12	GND
		13	+5V_CONT
		14	GND
		15	+5V_CONT
		16	GND
		17	+24V
		18	GND
		19	+24V
		20	GND
JSWISH1	Back USB host port (type A, tall, narrow)	1	SWISS_5V
		2	USB_DM_SWISSH
		3	USB_DPP_SWISSH
		4	GND
JT_PRE1	Sensor (tray present)	1	V_3.3_TRAY1
		2	S_TRAY1_C
		3	GND
JTHM1	Fuser thermistor	1	FUSER_TH_C
		2	GND

Power supply

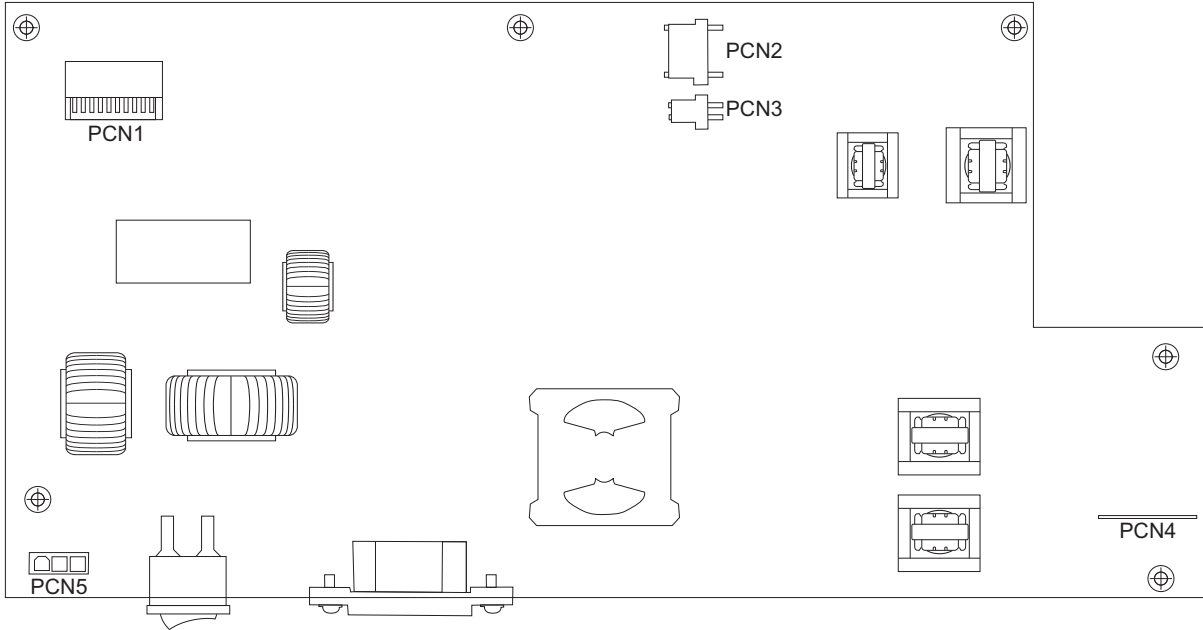

Maintenance

Inspection guide

The purpose of this inspection guide is to aid you in identifying the intervals, based on page count, at which parts must be inspected (for visible physical damage), cleaned, or replaced.

If any unsafe conditions exist, find out how serious the hazard could be and if you can continue before you correct the hazard.

As you service the machine, check for the following:

- Damaged, missing, or altered parts, especially in the area of the On/Off switch and the power supply
- Damaged, missing, or altered covers, especially in the area of the top cover and the power supply cover
- Possible safety exposure from any non-Lexmark attachments

Use the following table to determine when specified parts should be inspected:

PART	EVERY SERVICE CALL	EVERY 100K	EVERY 200K	EVERY 400K	NOTES
MEDIA TRAY—ALL					
Tray insert	Inspect	Inspect	Inspect	Replace	
Media side guides	Inspect	Inspect	Inspect		Check for correct positioning.
Media end guide	Inspect	Inspect	Inspect		Check for correct positioning.
Separation pad	Inspect	Clean	Clean		Damp cloth
Tray lift gear assembly		Inspect	Inspect		
Separation roller	Inspect	Inspect	Replace		Verify page count before replacing.
MEDIA FEEDERS—ALL					
Pick roller	Inspect	Inspect	Replace	Replace	Verify page count before replacing.
MPF feed rollers	Inspect	Inspect	Replace	Clean	Water or alcohol
Sensor		Clean	Clean	Clean	Brush or blower brush
TRANSFER ROLL					
Transfer roll	Inspect	Inspect	Replace	Replace	
FUSER UNIT					
Fuser unit	Inspect	Inspect	Replace	Inspect	
Sensor (fuser exit)		Clean	Clean	Clean	Blower brush
REDRIVE ASSEMBLY					
Redrive assembly		Inspect	Replace		Water
PART	EVERY 90K	EVERY 200K	NOTES		
ADF ASSEMBLY					
ADF separator roll		Replace			

PART	EVERY 90K	EVERY 200K	NOTES
ADF restraint pad			Replace if dirty, or if the ADF is shingle feeding.

Scheduled maintenance

The control panel displays an 80.xy error when it reaches 200K page counts. It is necessary to install the appropriate maintenance kit to maintain the print quality and reliability of the printer. Reset the maintenance counter after replacing the maintenance kit.

Maintenance kits

Part number and kit	Contents
40X9147—Maintenance Kit (100 V)	<ul style="list-style-type: none"> • Fuser (100V) • Redrive assembly • ACM tires/hubs • Transfer roll • Tray separator bracket • MPF pick roll and separator pad
40X9137—Maintenance Kit (110 V)	<ul style="list-style-type: none"> • Fuser (110V) • Redrive assembly • ACM tires/hubs • Transfer roll • Tray separator bracket • MPF pick roll and separator pad
40X9138—Maintenance Kit (220 V)	<ul style="list-style-type: none"> • Fuser (220V) • Redrive assembly • ACM tires/hubs • Transfer roll • Tray separator bracket • MPF pick roll and separator pad

When performing the 200K scheduled maintenance procedure, the following areas should be cleaned of media dust and toner contamination:

- Media trays
- Imaging unit area
- Transfer roll area
- Duplex area
- Standard bin

Resetting the maintenance counter

Always reset the maintenance counter after installing the maintenance kit.

To reset the maintenance counter:

- 1 POR into the Configuration menu, and navigate to **Reset Maintenance Counter**.
- 2 Depending on the printer model, press **OK** or touch  to reset the counter, or press **X** to exit without resetting the counter.

Once initiated, the operation cannot be canceled.

Lubrication specification

Lubricate only when the parts are replaced or if necessary, not on a scheduled basis. The use of lubricants other than those specified in this service manual may cause premature failure. Some unauthorized lubricants may chemically attack polycarbonate parts. Use Grease P/N 99A0394 Nyogel 744.

Cleaning the printer

Cleaning the printer

Note: You may need to perform this task after every few months.

Warning—Potential Damage: Damage to the printer caused by improper handling is not covered by the printer warranty.

- 1 Make sure that the printer is turned off and unplugged from the electrical outlet.

 **CAUTION—SHOCK HAZARD:** To avoid the risk of electrical shock when cleaning the exterior of the printer, unplug the power cord from the electrical outlet and disconnect all cables from the printer before proceeding.

- 2 Remove paper from the standard bin and multipurpose feeder.
- 3 Remove any dust, lint, and pieces of paper around the printer using a soft brush or vacuum.
- 4 Dampen a clean, lint-free cloth with water, and use it to wipe the outside of the printer.

Warning—Potential Damage: Do not use household cleaners or detergents to prevent damage to the exterior of the printer.

- 5 Make sure all areas of the printer are dry before sending a new print job.

Cleaning the scanner glass

Clean the scanner glass if you encounter print quality problems, such as streaks on copied or scanned images.

- 1 Slightly dampen a soft, lint-free cloth or paper towel with water.
- 2 Open the scanner cover.



- 3 Clean all the areas shown, and then let them dry.



1	White underside of the scanner cover
2	Scanner glass
3	ADF glass
4	White underside of the ADF cover

- 4 Close the scanner cover.

Cleaning the printhead lenses

Note: This is applicable only to models with galvo LSU. To determine whether the LSU is galvo, check the serial number of the printer. The sixth digit character assigned should be in the 0–9 or B–N range (Example: 4514 20HH 007CR).

- 1 Open the front door.
- 2 Remove the toner cartridge and imaging unit.
- 3 From the printhead access opening (A) in the top of the frame at the front of the printer, find the printhead lens.

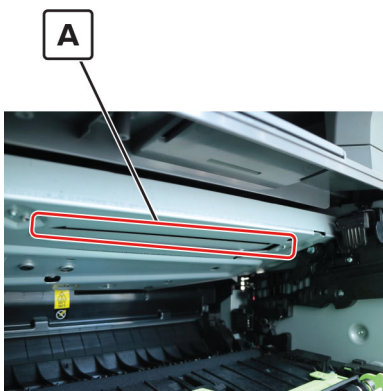

- 4 Insert a soft, lint-free cloth in the opening, and gently move the cloth back and forth along the surface of the lens to clean it.
- 5 Repeat step 4.
- 6 Reinstall the imaging unit and toner cartridge.
- 7 Close the front door.

Parts catalog

Legend

The following column headings are used in the parts catalog:

- **ASM-index**—Identifies the assembly and the item in the diagram. For example, 3-1 indicates Assembly 3 and item 1 in the table.
- **Part number**—Identifies the unique number that correlates with the part.
- **Units/mach**—Refers to the number of units actually used in the base machine or product.
- **Units/option**—Refers to the number of units in a particular option.
- **Units/FRU**—Refers to the number of units in a particular FRU.
- **Description**—A brief description of the part.

The following abbreviations are used in the parts catalog:

- **NS** (not shown) in the Asm-index column indicates that the part is procurable but is not pictured in the illustration.
- **PP** (parts packet) in the Description column indicates that the part is contained in a parts packet.

Assembly 1: Covers

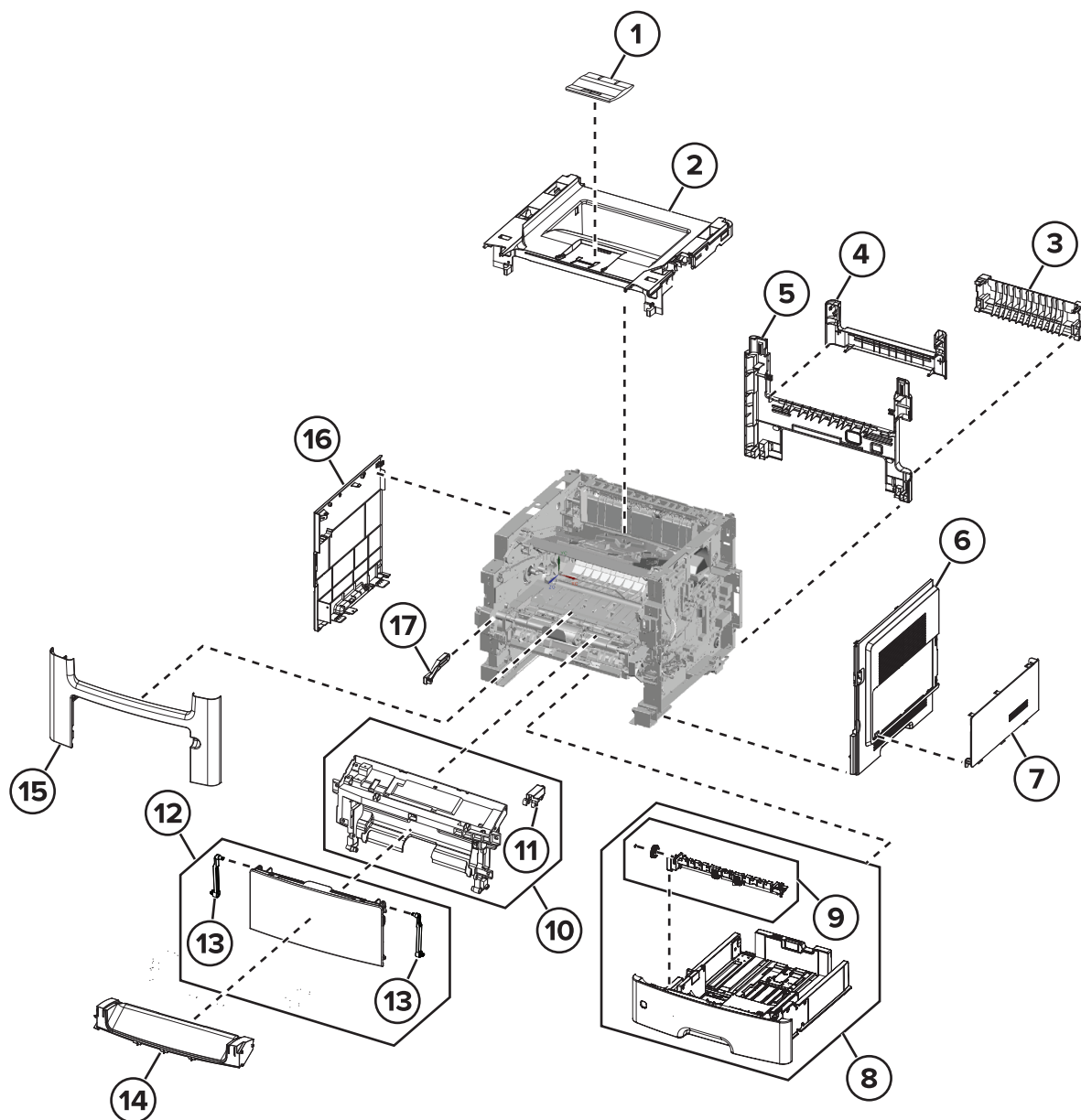

Assembly 1: Covers

Asm-index	P/N	Units/mach	Units/FRU	Description	Removal procedure
1	40X9102	1	1	Output expander	N/A
2	40X9099	1	1	Top cover	“Top cover removal” on page 391
3	40X9096	1	1	Exit rear door	“Rear exit door removal” on page 381
4	40X9084	1	1	Diverter cover	“Diverter cover removal” on page 390
5	40X9087	1	1	Rear cover	“Rear cover removal” on page 382
6	40X9090	1	1	Right cover	“Right cover removal” on page 315
7	40X9100	1	1	Memory access door (MPF)	“Memory access door removal” on page 318
8	40X8086	1	1	550-sheet tray insert	N/A
9	40X8444	1	1	Separator roll assembly	“Separator roll assembly removal” on page 416
10	40X9068	1	1	Front access cover (MPF)	“Front access cover removal” on page 354
11	40X9148	1	1	Cartridge plunger	“Cartridge plunger removal” on page 331
12	40X9131	1	1	MPF tray cover	“MPF tray removal” on page 349
13	41X0994	1	1	MPF tray links	“MPF tray removal” on page 349
14	40X9095	1	1	Front bin cover	“Front bin cover removal” on page 335
15	40X9101	1	1	Name plate cover	“Name plate cover removal” on page 333
16	40X9086	1	1	Left cover	“Left cover removal” on page 302
17	41X2300	1	1	Access cover link	N/A

Assembly 2: Imaging

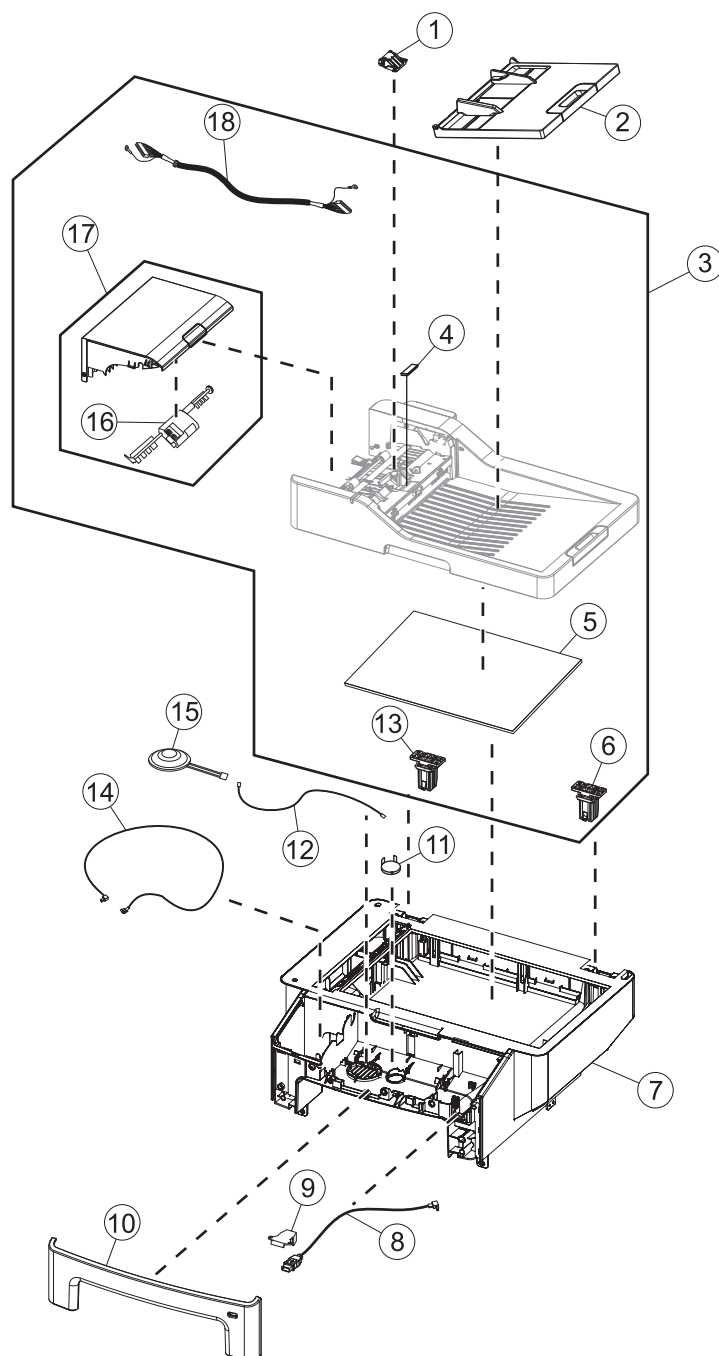

Assembly 2: Imaging

Asm-index	P/N	Units/mach	Units/FRU	Description	Removal procedure
1	41X0917	1	1	ADF separator roller	“ADF separator roll removal ” on page 399
2	40X9054	1	1	ADF input tray	“ADF input tray removal” on page 402
3	40X9093	1	1	ADF assembly	“ADF unit removal” on page 402
4	40X9110	1	1	Restraint pad	“Restraint pad removal” on page 414
5	40X5804	1	1	Flatbed cushion (legal)	“Flatbed cushion removal ” on page 400
6	40X7546	1	1	ADF right hinge	“ADF hinge removal” on page 411
7	40X9094	1	1	Flatbed	“Flatbed assembly removal” on page 412
8	40X9051	1	1	MPF USB cable	“USB cable removal” on page 409
9	40X9053	1	1	USB cable bracket	“USB cable bracket removal” on page 342
10	40X9097	1	1	Scanner front cover	“Scanner front cover removal” on page 401
11	40X9088	1	1	Cave light lens	“Cave light lens removal” on page 343
12	40X9080	1	1	Speaker cable	“Speaker cable removal” on page 412
13	40X9129	1	1	ADF left hinge	“ADF hinge removal” on page 411
14	40X9050	1	1	MPF wireless cable	“USB wireless cable removal” on page 410
15	40X9079	1	1	Speaker	“Speaker removal” on page 342
16	40X8736	1	1	ADF pick roll	N/A
17	40X9142	1	1	ADF top cover (legal)	“ADF top cover assembly removal” on page 407
18	40X9117	1	1	High end ADF cable	“ADF cable removal” on page 408

Assembly 3: Control panel

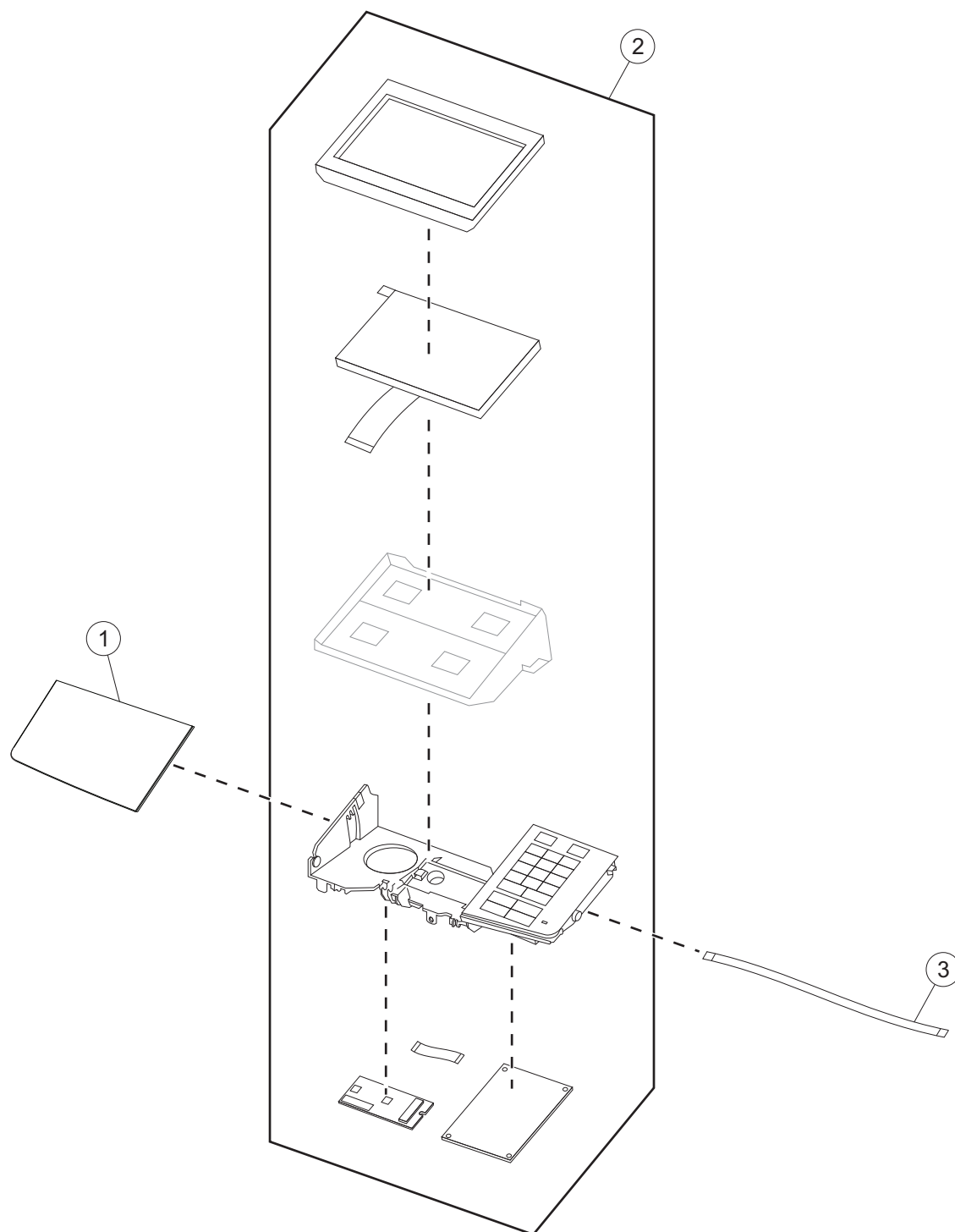

Assembly 3: Control panel

Asm-index	P/N	Units/mach	Units/FRU	Description	Removal procedure
1	40X9125	1	1	Control panel cover (MX610de)	“Control panel cover removal” on page 345
1	40X9132	1	1	Control panel cover (MX611de and XM3150)	“Control panel cover removal” on page 345
1	40X9133	1	1	Control panel cover (MX611dhe)	“Control panel cover removal” on page 345
1	41X2018	1	1	Control panel cover (MX617de)	“Control panel cover removal” on page 345
2	41X0756	1	1	Control panel assembly	“Control panel assembly removal” on page 336
3	40X9052	1	1	UICC cable	N/A

Assembly 4: Electronics 1

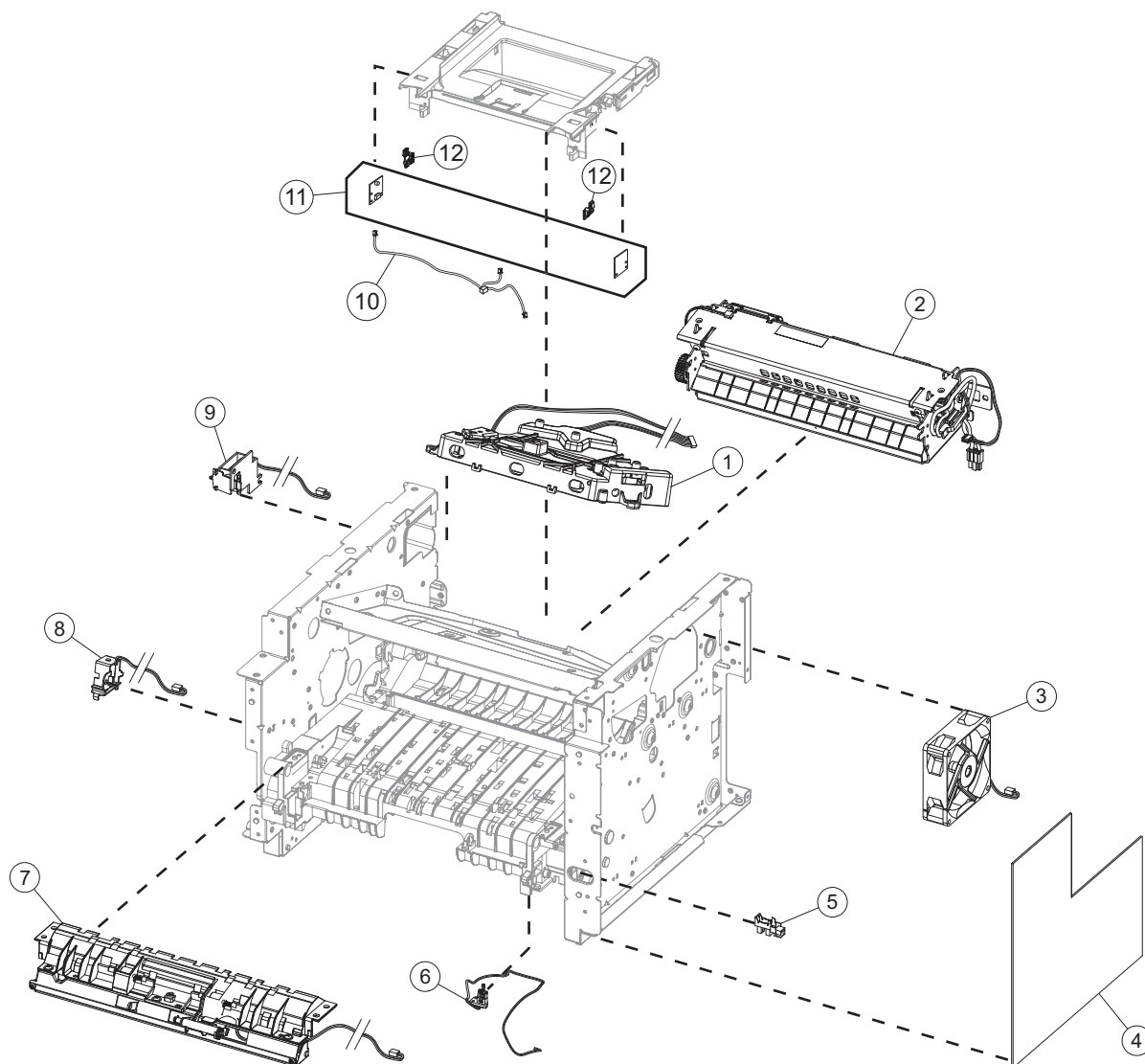

Assembly 4: Electronics 1

Asm-index	P/N	Units/mach	Units/FRU	Description	Removal procedure
1	40X8079	1	1	Galvo LSU*	“Laser scanning unit (LSU) removal” on page 395
1	41X0362	1	1	Polygon LSU*	“Laser scanning unit (LSU) removal” on page 395
2	40X8343	1	1	Fuser, 100 V	“Fuser removal” on page 386
2	40X8023	1	1	Fuser, 110 V	“Fuser removal” on page 386
2	40X8024	1	1	Fuser, 220 V	“Fuser removal” on page 386
3	40X9181	1	1	Cooling fan	“Cooling fan removal” on page 319
4	40X9254	1	1	Controller board* (galvo LSU)	“Controller board removal” on page 320
4	41X0485	1	1	Controller board* (polygon LSU)	“Controller board removal” on page 320
5	40X7592	1	1	Tray present sensor	“Tray present sensor removal” on page 318
6	41X0259	1	1	Narrow media sensor	N/A
7	40X8280	1	1	Front input guide	“Front input guide removal” on page 356
8	40X8300	1	1	MPF solenoid	“MPF solenoid removal” on page 306
9	40X8301	1	1	Reverse solenoid	“Reverse solenoid removal” on page 311
10	40X9126	1	1	Bin full sensor cable	“Bin full sensor cable removal” on page 394
11	40X9646	1	1	Bin full sensor	“Bin full sensor/lens removal” on page 392
12	40X9127	1	1	IR sensor lens	“Bin full sensor/lens removal” on page 392
NS	40X7854	1	1	Fax card	N/A
NS	41X0363	1	1	Polygon laser scanning unit (LSU) frame*	--
NS	41X0759	1	1	Polygon LSU cable	--
NS	41X0913	1	1	Video cable (galvo LSU)	--

* To determine what type of LSU (galvo or polygon) the printer supports and whether it is compatible with the controller board:

- Check the serial number of the printer. If the sixth digit character assigned is in the P–Z range, then the LSU is polygon (example: 4514 2ZHH 007CR). If the sixth digit character assigned is in the 0–9 or B–N range, then the LSU is galvo (example: 4514 20HH 007CR7).
- Check the color of the controller board. For polygon LSU, the color of the compatible controller board is blue. For galvo LSU, the color is green.

Assembly 5: Electronics 2

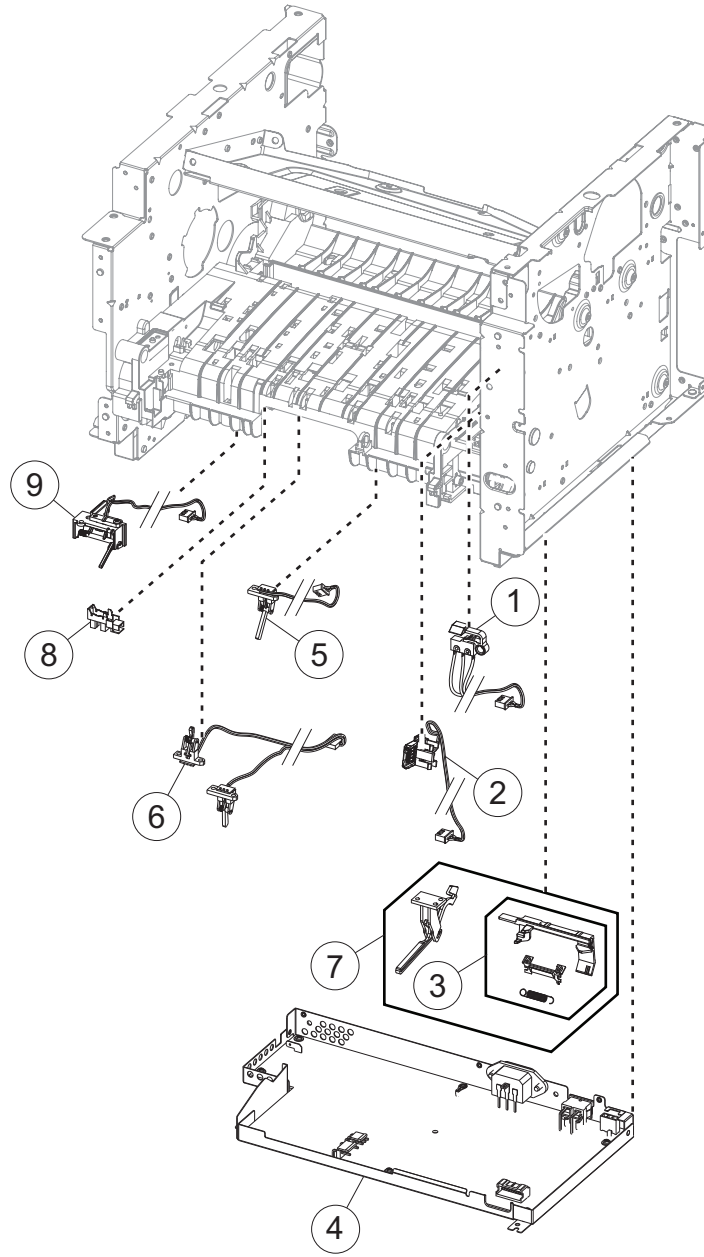

Assembly 5: Electronics 2

Asm-index	P/N	Units/mach	Units/FRU	Description	Removal procedure
1	40X8048	1	1	Front door sensor	“Front door sensor removal” on page 356
2	40X8266	1	1	Cartridge smart chip contact	“Toner cartridge smart chip contact removal” on page 324
3	41X4456	1	1	Toner density sensor kit <ul style="list-style-type: none"> • Toner density sensor and bracket • Spring • Screw • Grease 	“Sensor (toner density) and media present sensor flag removal” on page 374
4	40X7797	1	1	Power supply, 100 V/110 V	“Power supply removal” on page 361
4	40X7798	1	1	Power supply, 220 V	“Power supply removal” on page 361
5	40X8044	1	1	Index sensor	“Index sensor removal” on page 366
6	40X8043	1	1	Duplex sensor and input sensor	“Duplex sensor and input sensor removal” on page 363
7	41X4453	1	1	Paper present sensor flag kit <ul style="list-style-type: none"> • Paper present sensor flag and bracket • Toner density sensor and bracket • Spring • Screw • Grease 	“Sensor (toner density) and media present sensor flag removal” on page 374
8	40X7592	1	1	Media present sensor	“Media present sensor removal” on page 366
9	40X8045	1	1	Trailing edge sensor	“Trailing edge sensor removal” on page 368

Assembly 6: Frame

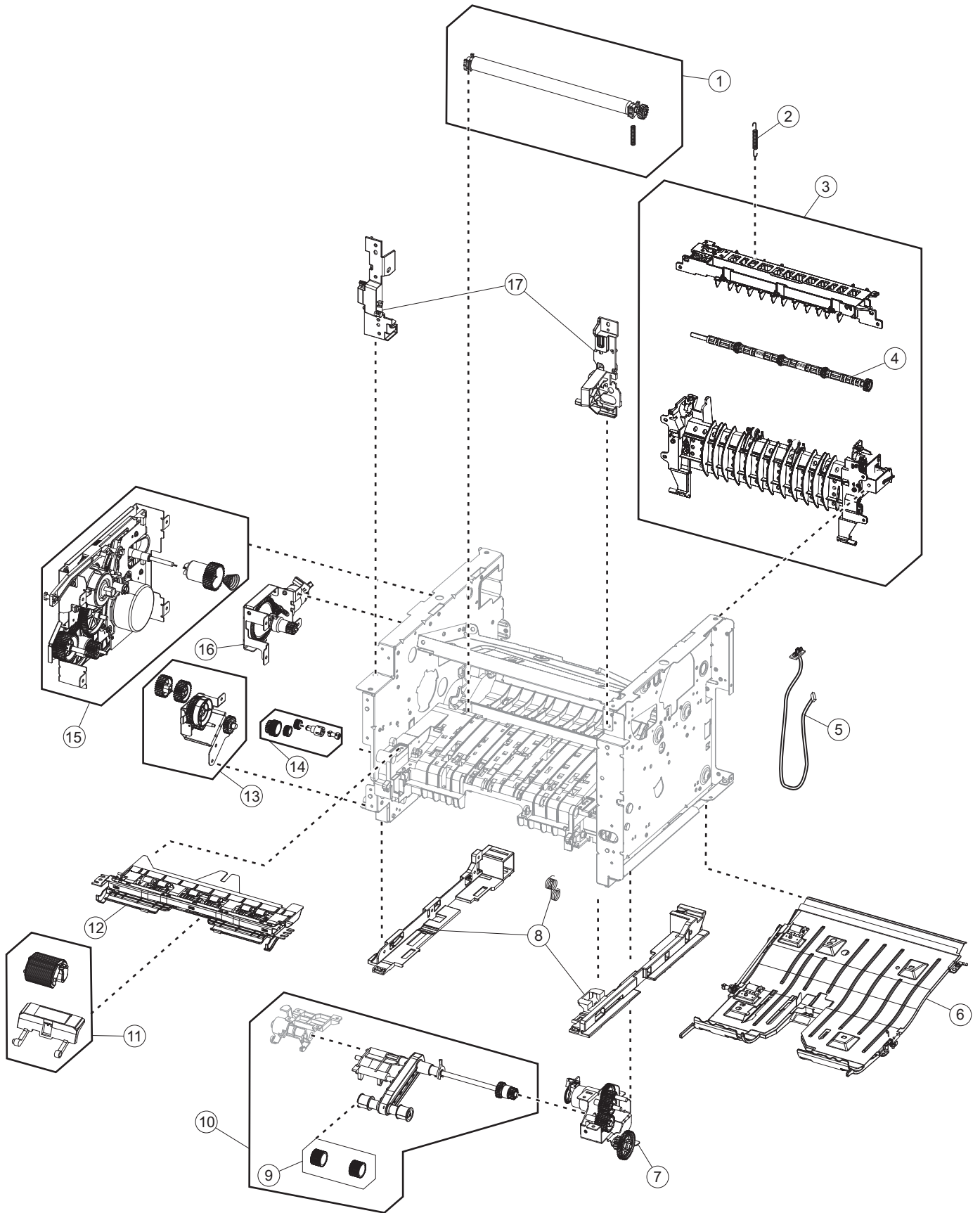

Assembly 6: Frame

Asm-index	P/N	Units/mach	Units/FRU	Description	Removal procedure
1	40X8393	1	1	Transfer roll	“Transfer roll removal” on page 330
2	40X9098	1	1	Stapler diverter spring	“Diverter spring removal” on page 389
3	40X9082	1	1	Redrive assembly	“Redrive assembly removal” on page 383
4	40X8850	1	1	Redrive shaft	“Redrive shaft removal” on page 384
5	40X9116	1	1	Stapler cable	“Stapler cable removal” on page 387
6	40X8275	1	1	Duplex assembly	“Duplex removal” on page 362
7	40X8084	1	1	ACM liftplate gearbox	“Pick/lift motor gearbox removal” on page 371
8	40X9523	1	1	Tray guide	“Tray guide removal” on page 372
9	41X0958	2	2	Pick tire	N/A
10	41X0959	1	1	ACM assembly (standard tray only)	“ACM assembly removal” on page 369
11	40X8295	2	2	MPF pick roller and separator pad	“MPF pick roller removal” on page 352 and “Separator pad removal” on page 358
12	40X8279	1	1	Jam access cover	“Jam access cover removal” on page 353
13	40X8777	1	1	MPF gearbox	“MPF gearbox removal” on page 308
14	40X8277	1	1	Duplex gear assembly	“Duplex gear assembly removal” on page 313
15	40X8085	1	1	Main drive gearbox	“Main drive gearbox removal” on page 304
16	40X8083	1	1	Cartridge gearbox	“Cartridge gearbox removal” on page 312
17	40X8299	1	1	Front mounts	“Left front mount removal” on page 327 “Right front mount removal” on page 328

Assembly 7: Option trays

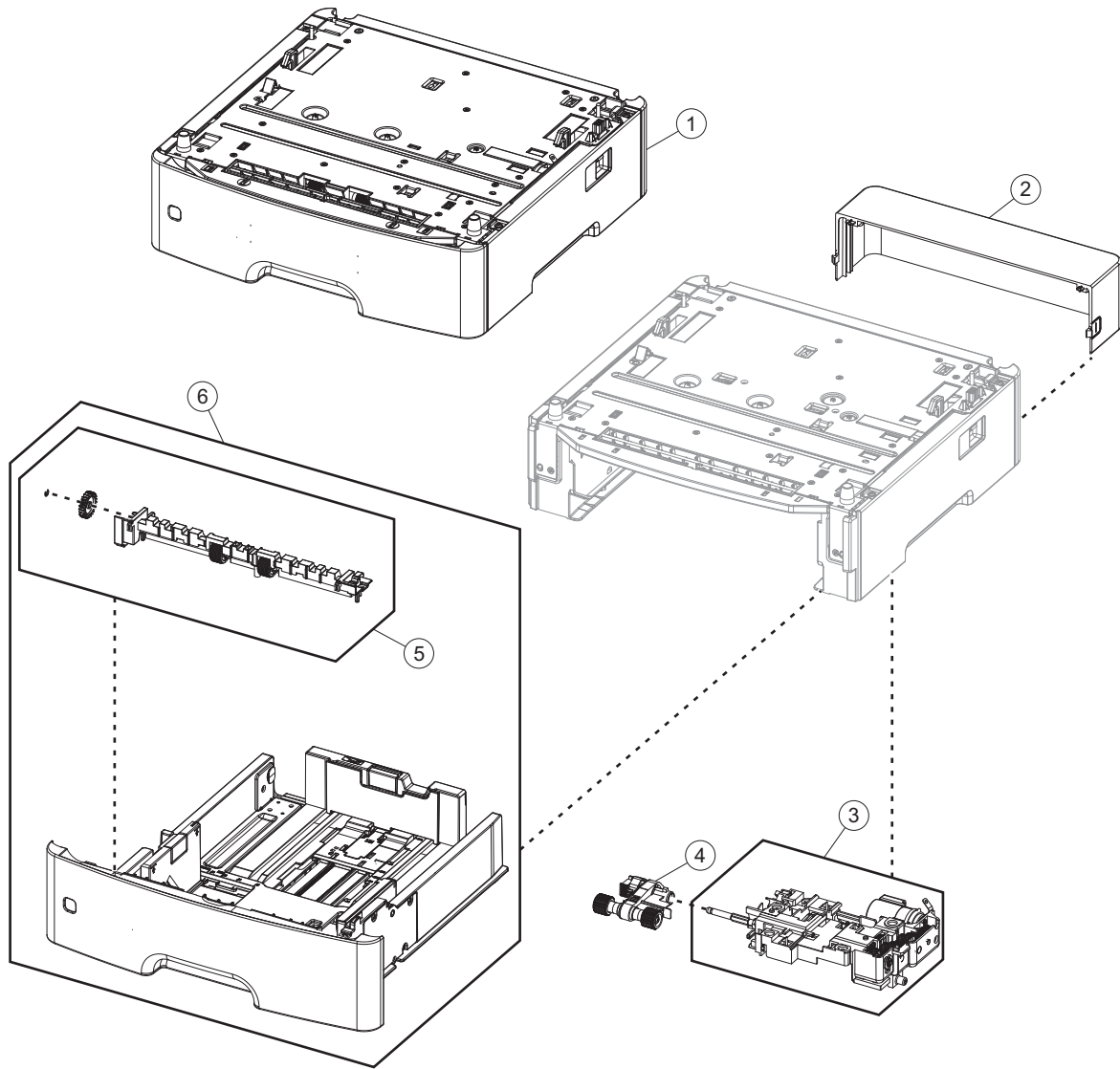

Assembly 7: Option trays

Asm-index	P/N	Units/mach	Units/FRU	Description	Removal procedure
1	40X8287	1	1	250-sheet tray	N/A
1	40X8286	1	1	550-sheet tray	N/A
1	40X9654	1	1	550-sheet tray, lockable	N/A
2	40X8520	1	1	Dust cover, 250-sheet tray	“Dust cover removal” on page 381
2	40X8521	1	1	Dust cover, 550-sheet tray	“Dust cover removal” on page 381
3	40X8262	1	1	ACM assembly (option tray only)	“ACM assembly removal” on page 418
4	40X8443	1	1	Pick roller assembly	“Pick roller removal” on page 415
5	40X8444	1	1	Separator roll assembly	“Separator roll assembly removal” on page 416
6	40X8528	1	1	250-sheet tray insert (option tray only)	N/A
6	40X8529	1	1	550-sheet tray insert (option tray only)	N/A

Assembly 8: Staple finisher option

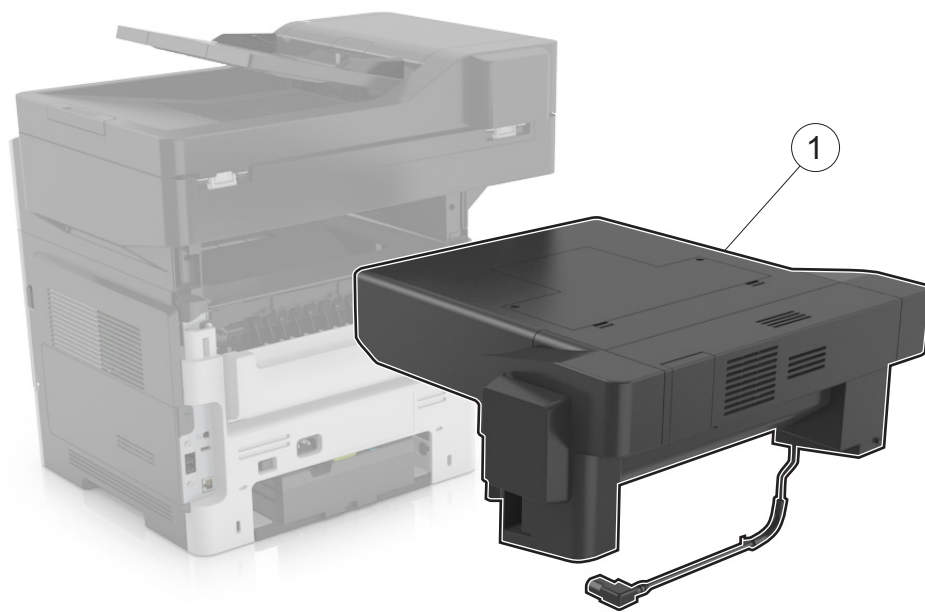

Assembly 8: Staple finisher option

Asm-index	P/N	Units/mach	Units/FRU	Description	Removal procedure
1	40X8121	1	1	Staple finisher option	“Staple finisher option removal” on page 421

Assembly 9: Staple finisher (right)

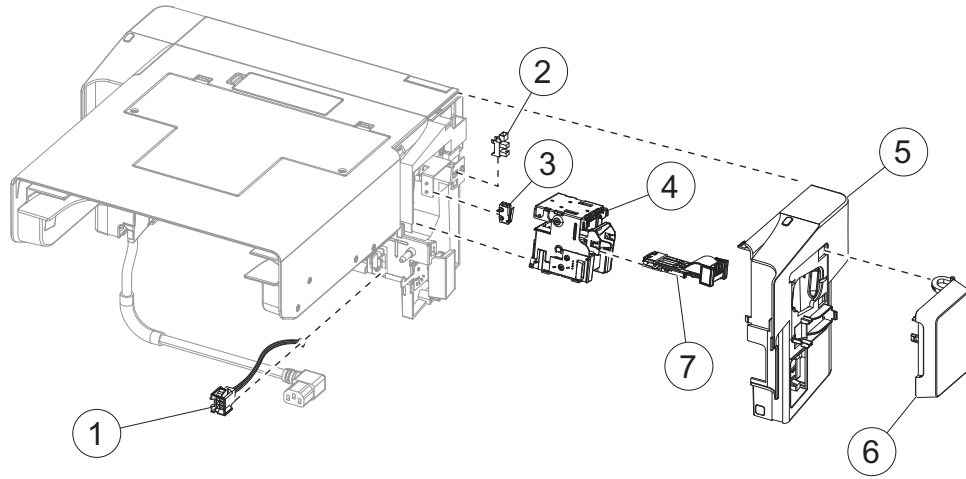

Assembly 9: Staple finisher (right)

Asm-index	P/N	Units/mach	Units/FRU	Description	Removal procedure
1	40X8144	1	1	Stapler interface cable	“Stapler interface cable removal” on page 443
2	40X7592	1	1	Sensor (stapler access door)	“Sensor (stapler access door) removal” on page 427
3	40X8139	1	1	Stapler door close limit switch with cable	“Stapler door close limit switch removal” on page 429
4	40X8142	1	1	Stapler carriage assembly	“Stapler carriage assembly removal” on page 427
5	40X8130	1	1	Stapler right cover	“Stapler right cover removal” on page 424
6	40X8129	1	1	Stapler cartridge access door	“Stapler cartridge access door removal” on page 422
7	40X8149	1	1	Staple roll holder	“Staple roll holder removal” on page 423

Assembly 10: Staple finisher (top)

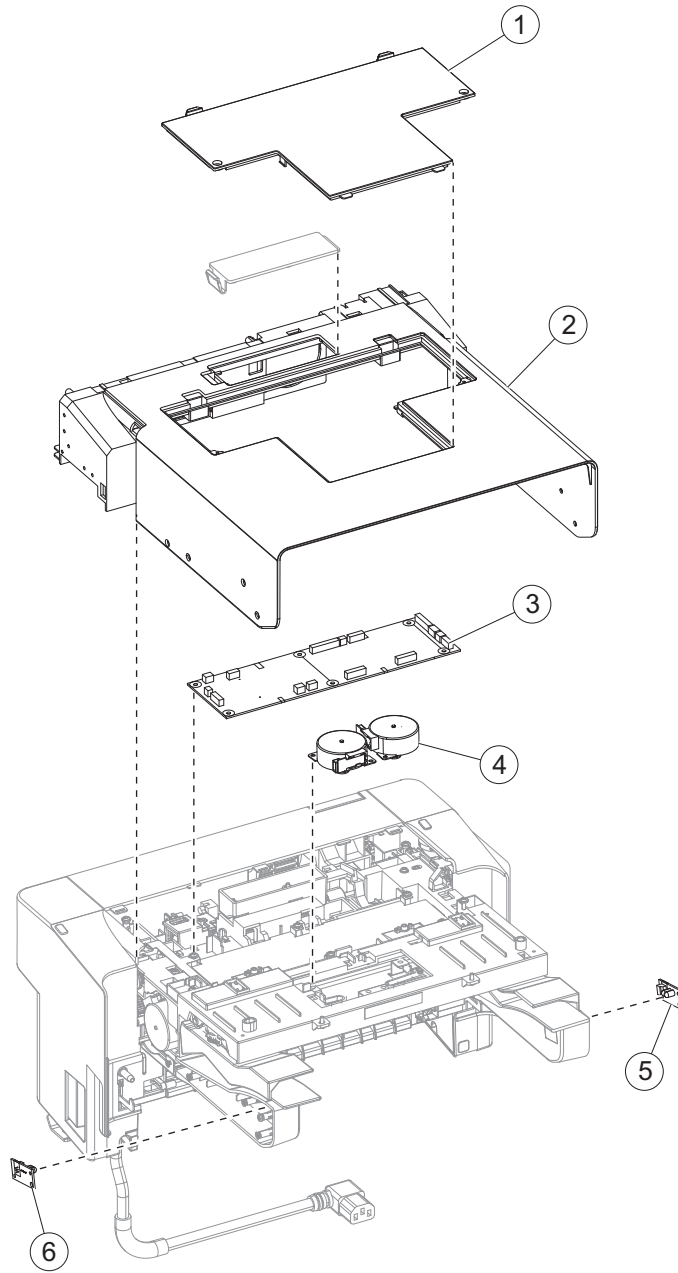

Assembly 10: Staple finisher (top)

Asm-index	P/N	Units/mach	Units/FRU	Description	Removal procedure
1	40X8140	1	1	Stapler service cover	“Stapler service cover removal” on page 437
2	40X8141	1	1	Stapler top cover	“Stapler top cover removal” on page 445
3	40X8137	1	1	Stapler controller card	“Stapler controller card removal” on page 437
4	40X8125	1	1	Stapler tamper motor	“Stapler left tamper motor removal” on page 437 or “Stapler right tamper motor removal” on page 438
5	40X8131	1	1	Sensor (stapler bin full send)	“Sensor (stapler bin full send) removal” on page 450
6	40X8132	1	1	Sensor (stapler bin full receive)	“Sensor (stapler bin full receive) removal” on page 448

Assembly 11: Staple finisher (rear)

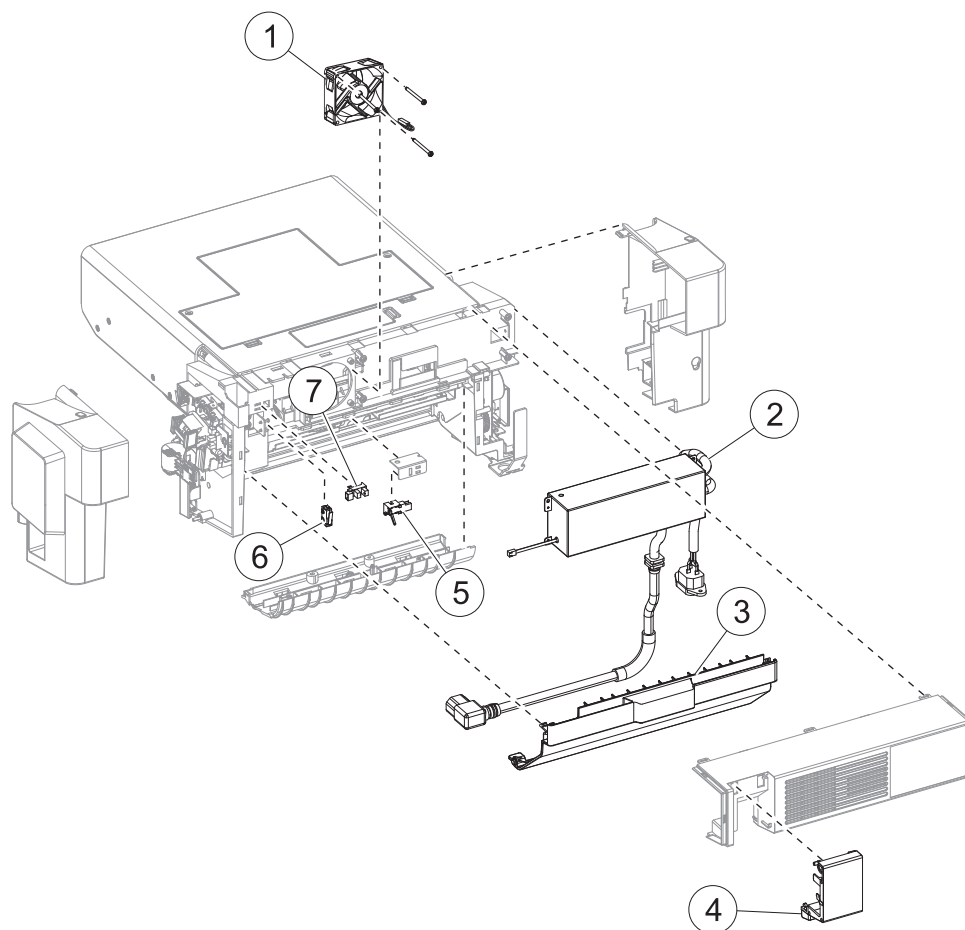

Assembly 11: Staple finisher (rear)

Asm-index	P/N	Units/mach	Units/FRU	Description	Removal procedure
1	40X8148	1	1	Stapler cooling fan	“Stapler cooling fan removal” on page 441
2	40X8135	1	1	Stapler power supply unit	“Stapler power supply unit removal” on page 441
2	40X8540	1	1	Stapler power supply unit—China	“Stapler power supply unit removal” on page 441
3	40X8128	1	1	Stapler rear door	“Stapler rear door removal” on page 426
4	40X8458	1	1	Trapped staple access door	“Trapped staple access door removal” on page 436
5	40X8134	1	1	Sensor (stapler pass through)	“Sensor (stapler pass through) removal” on page 453
6	40X8138	1	1	Stapler rear door close limit switch with cable	“Stapler rear cover close limit switch removal” on page 439
7	40X7592	1	1	Sensor (stapler rear door)	“Sensor (stapler rear cover) removal” on page 434

Assembly 12: Staple finisher exit assembly

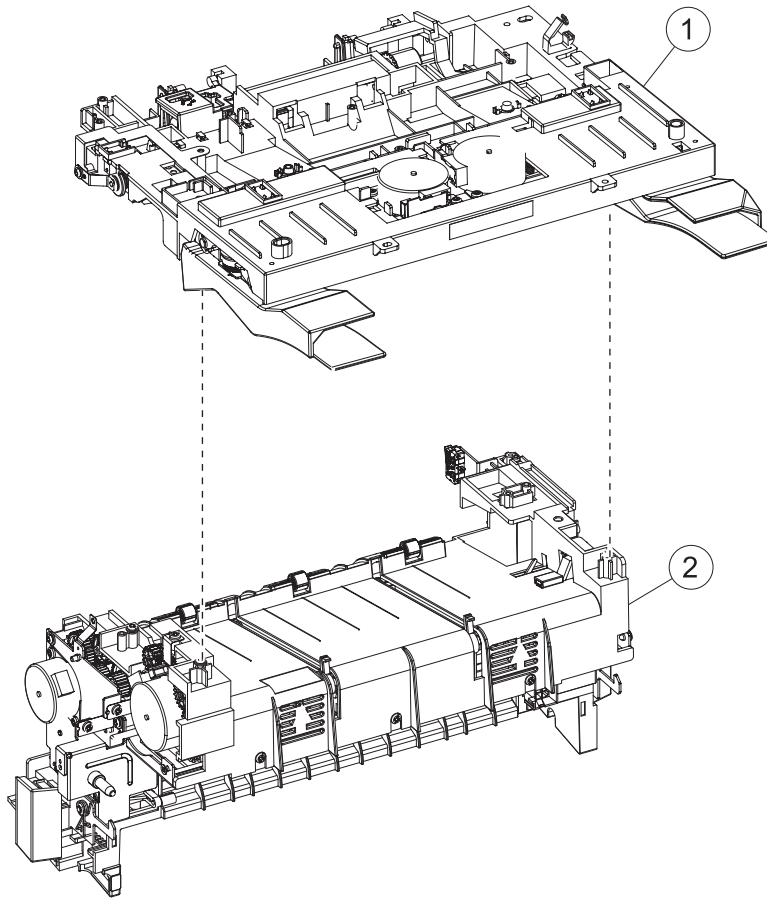

Assembly 12: Staple finisher exit assembly

Asm-index	P/N	Units/mach	Units/FRU	Description	Removal procedure
1	40X8748	1	1	Stapler tamper main assembly	“Tamper main assembly removal” on page 455
2	40X8751	1	1	Stapler accumulator assembly	“Stapler accumulator assembly removal” on page 462

Assembly 13: Staple finisher tamper assembly

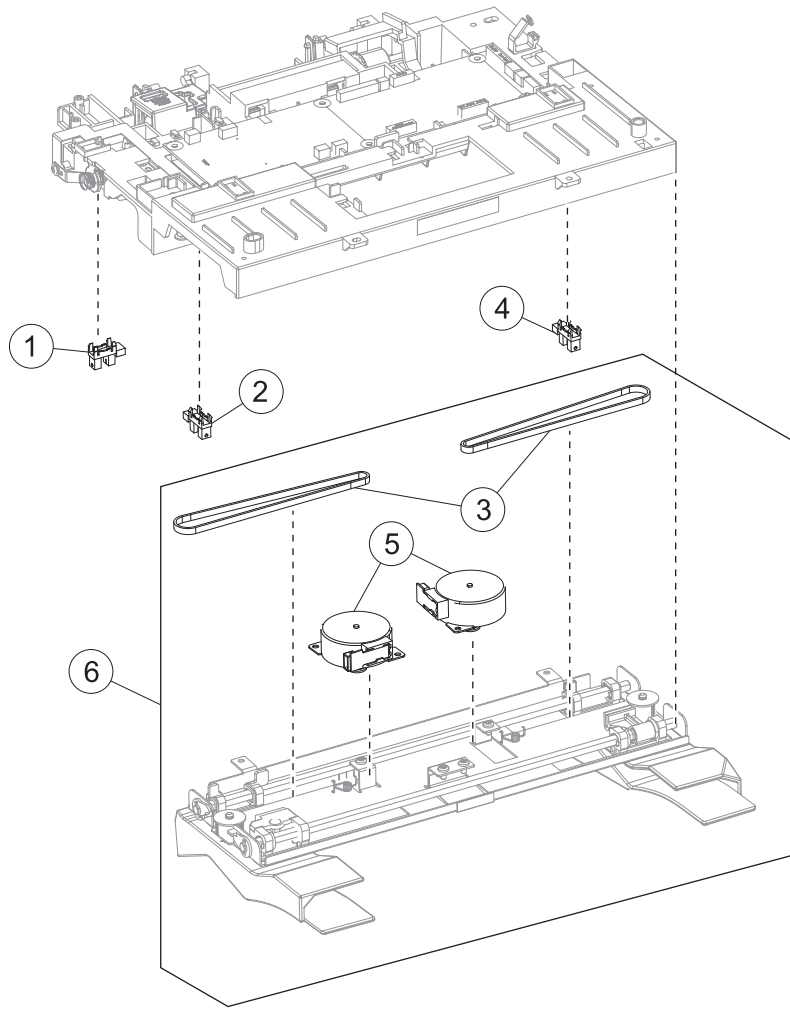

Assembly 13: Staple finisher tamper assembly

Asm-index	P/N	Units/mach	Units/FRU	Description	Removal procedure
1	40X8754	1	1	Sensor (stapler paddle HP)	“Sensor (stapler paddle HP) removal” on page 464
2	40X8754	1	1	Sensor (stapler left tamper HP)	“Sensor (stapler left tamper HP) removal” on page 463
3	40X8750	2	2	Stapler tamper drive belt	“Tamper drive belt removal” on page 458
4	40X8754	1	1	Sensor (stapler right tamper HP)	“Sensor (stapler right tamper HP) removal” on page 462
5	40X8125	2	1	Stapler tamper motor	“Stapler left tamper motor removal” on page 437 or “Stapler right tamper motor removal” on page 438
6	40X8749	1	1	Tamper sub-assembly	“Tamper sub-assembly removal” on page 456

Assembly 14: Staple finisher accumulator assembly

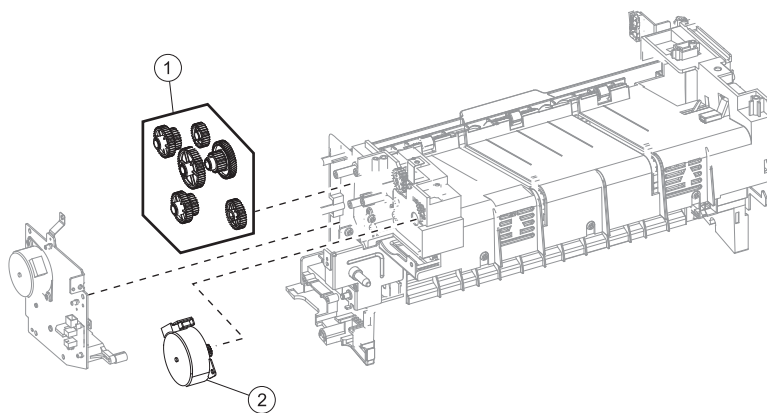

Assembly 14: Staple finisher accumulator assembly

Asm-index	P/N	Units/mach	Units/FRU	Description	Removal procedure
1	40X8752	1	1	Stapler diverter gearbox	“Diverter gearbox removal” on page 459
2	40X8753	1	1	Stapler paddle motor	“Stapler paddle motor removal” on page 433

Assembly 15: Maintenance kits

Asm-index	P/N	Units/mach	Units/FRU	Description	Removal procedure
NS	40X9147	1	1	Maintenance kit, 100 V	N/A
NS	40X9137	1	1	Maintenance kit, 110 V	N/A
NS	40X9138	1	1	Maintenance kit, 220 V	N/A

Assembly 16: Power cords

Asm-index	P/N	Units/mach	Units/FRU	Description	Removal procedure
NS	40X0269	1	1	Power cord, 2.5 m (straight)—USA, Canada	N/A
NS	40X3141	1	1	Power cord, 2.5 m (straight)—Europe and others	N/A
NS	40X0288	1	1	Power cord, 2.5 m (straight)—Argentina	N/A
NS	40X0271	1	1	Power cord, 2.5 m (straight)—United Kingdom	N/A
NS	40X0275	1	1	Power cord, 2.5 m (straight)—Israel	N/A
NS	40X1772	1	1	Power cord, 2.5 m (straight)—Switzerland	N/A
NS	40X1773	1	1	Power cord, 2.5 m (straight)—South Africa	N/A
NS	40X0273	1	1	Power cord, 2.5 m (straight)—Traditional Italy	N/A
NS	40X1774	1	1	Power cord, 2.5 m (straight)—Denmark	N/A
NS	40X4596	1	1	Power cord, 2.5 m (straight)—Brazil	N/A
NS	40X0303	1	1	Power cord, 2.5 m (straight)—China	N/A
NS	40X0270	1	1	Power cord, 2.5 m (straight)—Japan	N/A
NS	40X1792	1	1	Power cord, 2.5 m (straight)—Korea	N/A
NS	40X1791	1	1	Power cord, 2.5 m (straight)—Taiwan	N/A
NS	40X0301	1	1	Power cord, 2.5 m (straight)—Australia	N/A

Assembly 17: Miscellaneous

Asm-index	P/N	Units/mach	Units/FRU	Description	Removal procedure
NS	40X7856	1	1	Hard disk drive (ATA pass through)	N/A
NS	40X7858	1	1	Adapter, 802.11B/G/N - US	N/A
NS	40X4819	1	1	Adapter, RS232C serial	N/A
NS	40X5315	1	1	Screw, shipped with ISP (2PER)	N/A
NS	40X5316	1	1	Cable, 14-pin JST- for ISP	N/A
NS	40X5317	1	1	Standoff, tee with thumbscrew	N/A
NS	40X4826	1	1	Adapter, N8120 GB INA	N/A
NS	40X4823	1	1	Adapter, parallel 1284-B THCK	N/A
NS	40X9652	1	1	Adapter, N8130 10/100 fiber	N/A
NS	40X8525	1	1	Adapter, fiber ISP Note: This part is obsolete.	N/A
NS	40X8556	1	1	Font card, Traditional Chinese	N/A
NS	40X8557	1	1	Font card, Simplified Chinese	N/A
NS	40X8568	1	1	Font card, Korean	N/A
NS	40X8569	1	1	Font card, Japanese	N/A
NS	40X1368	1	1	USB cable, packaged (2 meters)	N/A
NS	41X0866	1	1	Forms and Bar code card Note: This part is obsolete.	N/A
NS	40X8657	1	1	IPDS card Note: This part is obsolete.	N/A
NS	41X0868	1	1	Prescribe card Note: This part is obsolete.	N/A
NS	40X7445	1	1	2GB DDR3 DIMM	N/A
NS	40X7567	1	1	1GB DDR3 DIMM	N/A
NS	40X8570	1	1	Font card, Arabic	N/A
NS	40X8571	1	1	Font card, Hebrew	N/A
NS	40X8524	1	1	Parallel 1284-B interface card	N/A
NS	40X8523	1	1	RS-232C Serial Interface Card	N/A
NS	40X8526	1	1	MarkNet N8350 802.11 b/g/n Wireless Print Server	N/A
NS	41X1946	1	1	N8230 Fiber ISP with Backpack	N/A
NS	41X0568	1	1	MarkNet N8350 802.11 b/g/n Wireless Print Server with NFC	N/A

Asm-index	P/N	Units/mach	Units/FRU	Description	Removal procedure
NS	40X8700	1	1	Relocation kit	N/A
NS	40X9879	1	1	Smart card reader	N/A

Printer specifications

Electrical specifications

Low-voltage models

- 100 to 127 V AC at 50 to 60 hertz (Hz) nominal
- 90 to 137 V AC, extreme

High-voltage models

- 220 to 240 V AC at 50 to 60 hertz (Hz) nominal (not available in all countries and regions)

Applicability of Regulation (EU) 2019/2015 and (EU) 2019/2020

Per Commission Regulation (EU) 2019/2015 and (EU) 2019/2020, the light source contained within this product or its component is intended to be used for Image Capture or Image Projection only, and is not intended for use in other applications.

Operating clearances

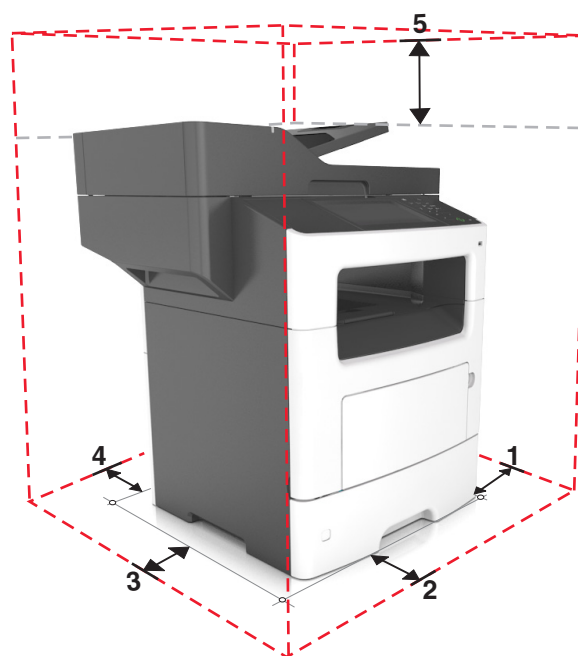

1	Right	30 cm (12 in.)
2	Front	51 cm (20 in.)
3	Left	20 cm (8 in.)
4	Rear	20 cm (8 in.)

5	Top	80 cm (31 in.)
Allow additional clearance around the printer for adding the optional input trays.		

Acoustics

All measurements are made in accordance with ISO 7779 and conform with ISO 9296.

Status	1 meter average sound pressure dBA	Declared sound power level (Bels)
Idle (Standby)	16 dBA	3.3 Bels
Quiet Mode	50 dBA	6.5 Bels
Printing	55 dBA	7.0 Bels
Sleep Mode	16 dBA	3.3 Bels

Operating environment

Environment	Specification
Temperature—printer operating	60 to 90 °F (16 to 32 °C)
Relative humidity—printer operating	8 to 80%
Maximum wet bulb temperature—printer operating	73 °F (23 °C)
Temperature—printer off	50 to 110 °F (10 to 43 °C)
Relative humidity—printer off	8 to 80%
Maximum wet bulb temperature—printer off	80 °F (27 °C)
Temperature—ambient operating environment*	60 to 90 °F (16 to 32 °C)
Relative humidity—ambient operating environment*	8 to 80%
Temperature—storage and shipping (packaged printer) with or without print cartridge	-40 to 110 °F (-40 to 43 °C)
Altitude	10,000 ft (0 to 3,048 m)
Atmospheric pressure	74.6 kPa
Tilt	2°
*In some cases, performance specifications (such as paper OCF, EP cartridge usage) are measured at an ambient condition.	

Scanner specifications

Imaging technology: CCD—Charge coupled device

Scan resolution: 1200 x 600 dpi

Legal flatbed maximum document size: 216 x 356 mm

ADF input capacity: 50 sheets

Dimensions	Letter, Legal, A4, A5, A6, JISB5, Folio, Officio, Executive, Statement
Weight	16–24 lb, 64–90 gm/m ²
Simplex	Up to 50 ppm
Duplex	45 images/minute in simplex, 20 images/minute in duplex mode
50 images/minute at 600 x 300 dpi mono	
32 images/minute at 600 x 300 dpi color	
Temperature	60 to 90 °F (16 to 32 °C)
Humidity	8% to 80%
Atmospheric pressure	101 to 74.6 kPa
Tilt	0 to 5 ° from horizontal
Temperature	50 to 110 °F (10 to 43 °C)
Humidity	8% to 80%
Atmospheric pressure	101 to 74.6 kPa
Storage angle	The scanner module shall operate as specified after storage for up to one year in any orientation.
Legal flatbed	120,000 pages
Duplex ADF	220,000 pages

Fax specifications

Modem speed	33.6 Kbps
Transmission speed	3 seconds/page ²
Maximum resolution	600 x 6300 dpi
Color fax	Supported—send only
Fax memory	19 MB w/o hard disk; HDD—1 GB
Compression methods	JBIG2, MR, MMR, MHE, JPEG
Fax server	Supported
PC fax	Supported—send and receive
Speed dial locations	500
Broadcast locations	400
Dinstinctive ring	Supported
Secure fax	Supported

Other functions supported	Fax scheduling, fax forwarding, junk fax block, manual fax
---------------------------	--

Options and features

Some of the following options are not available in every country or region.

Available internal options

Memory cards

- Flash memory
- Fonts

Media handling options

Some options may not be available for all models.

1	Standard 250-sheet tray
2	Optional 550-sheet tray
3	Optional 250-sheet tray
4	Multipurpose feeder
* Any combination of 550-sheet and 250-sheet trays may be installed up to a total of 3 optional trays.	

Theory of operation

POR sequence

As the printer is turned on, the engine code goes through a series of tests to verify hardware integrity. If a hardware failure is detected, then it is reported to the printer. If the POR sequence cannot be completed successfully, then the printer may post an error message. The message states that service may be needed.

Printer control

The printer uses a single processor for both RIP and engine functions. The raster image processor (RIP) code performs system responsibilities such as PC connection, LAN, ISP attachments, and bitmap generation. The engine code performs tasks related to the operation of the electrical and mechanical device systems such as motors, lasers, power supplies, and fusers. The NVRAMs are located on the controller board and control panel, replacement of either the controller board or control panel will pull or mirror NVRAM data from each other.

Paper path information

Input tray

Component functions for feeding from the tray:

- Tray present sensor—Detects if the tray is inserted
- Media present sensor—Detects whether the media level is empty or low.
- Pick/Lift motor—Supplies the mechanical power requirements of the lift plate and the pick rollers.

When feeding media, the front part of the lift plate is raised, pressing the media to the pick rollers. The pick rollers rotate to feed the media to the separator rolls. The separator rolls rotate in a direction opposite to the pick rollers. This ensures that sheets are fed one at a time. The media is then fed to the secondary input roller and then to the first input roller.

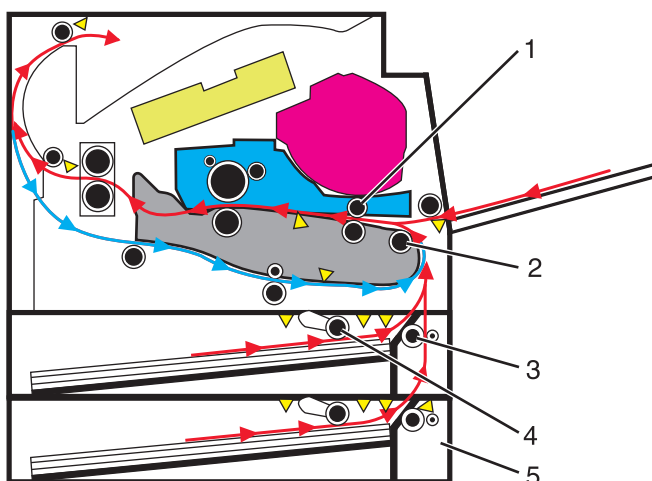

#	Part
1	First input roller
2	Secondary input roller
3	Separator roller
4	Pick rollers
5	Option tray

Multipurpose feeder (MPF)

The driving force from the main drive motor is transmitted through the MPF gearbox. When the MPF solenoid activates, it allows the MPF sector gear linked to the MPF gearbox to rotate. The MPF pick roll shaft is connected to the MPF sector gear.

The MPF can be accessed by opening the MPF tray on the front door. In an MPF paper feed, the MPF paper present sensor detects the media. The instant the MPF pick roll shaft rotates, the cams on each end of the shaft disengage the MPF tray. Each side of the tray is connected to the front access cover by springs. When disengaged from the shaft, the springs pull the tray causing the media to come into contact with the MPF pick roller. At the same time the pick roller rotates, pushing the media to the separator pad. The media does not pass through the secondary input roller, but directly to the first input roller.

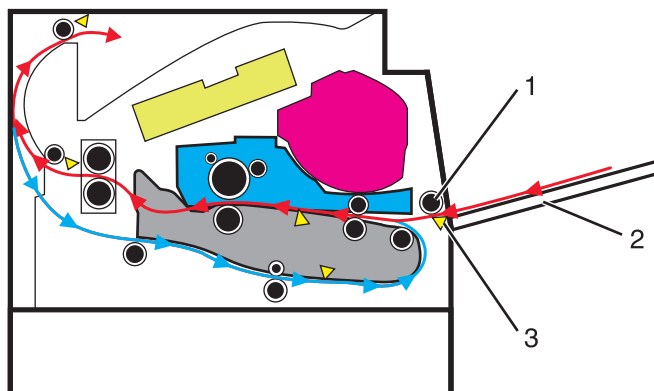

#	Part
1	MPF pick roller
2	MPF tray
3	MPF paper present sensor

Simplex printing

Situated along the first input roller, is the deskew shutter. It subjects the media to a deskewing force based on the media width. The direction of the force is transverse to the feed direction. The leading edge of the media then passes through the input sensor.

After the edge of the media is aligned, the first input roller feeds the media to the transfer roll for toner transfer. At this point, the toner image is already on the photoconductor drum surface. As the media passes between the photoconductor drum and transfer roll, the toner image is transferred to the media.

The media with the embedded toner image goes through the fuser assembly to permanently bond the toner to the media. When it passes between the heat belt and pressure roll of the fuser assembly, the combination of heat and pressure fuses the toner image to the media. The fuser exit roller feeds the media to the paper exit roller and then to the output bin.

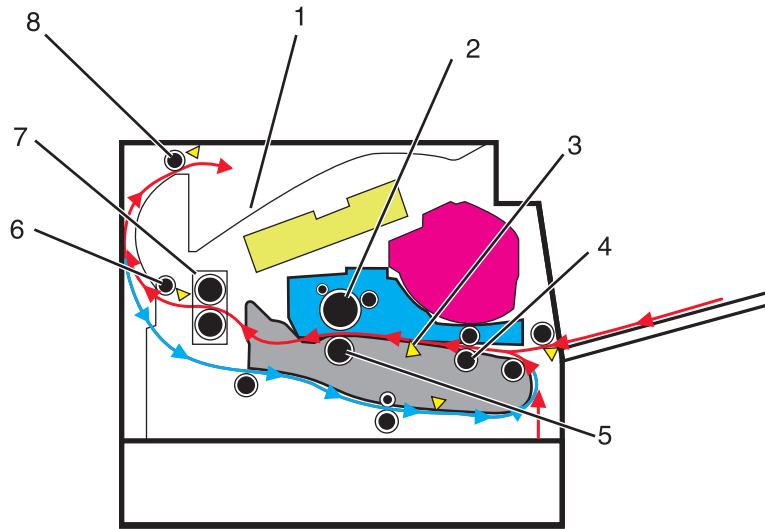

#	Part
1	Output bin
2	Photoconductor drum
3	Input sensor
4	First input roller
5	Transfer roller
6	Fuser exit roller
7	Fuser assembly
8	Paper exit roller

Duplex printing

After the first side of the media has been printed on and is partially fed out to the output bin, the duplex solenoid activates. This causes the exit roller to reverse its rotation and feed the media, with its trailing edge first, back into the redrive assembly and then to the duplex paper path. The duplex front and rear deliver rollers move the media through the duplex paper path, the diverter, the first input roller, and back to the primary paper path. The same process for printing on the first side of the media repeats, this time for the second side of the media.

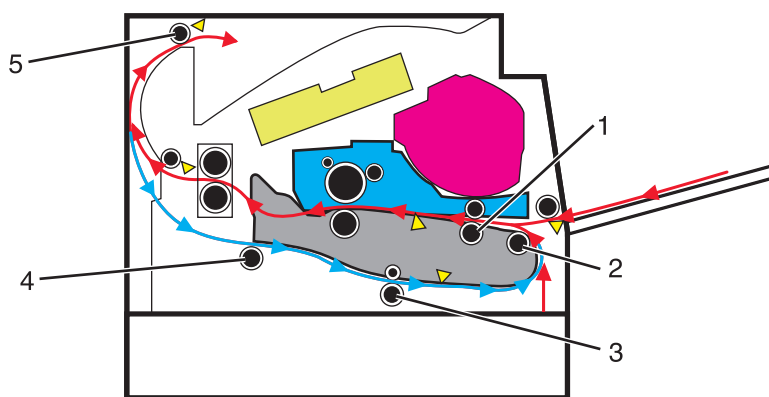

#	Part
1	First input roller
2	Secondary input roller
3	Duplex front deliver roller
4	Duplex rear deliver roller
5	Paper exit roller

Media handling components

Main drive gearbox

The gearbox supplies all mechanical power requirements of the printer. Its motor, through several gears, transfers power to following paths: photoconductor drum, transfer roll, fuser, paper exit, input, duplex, and MPF.

Aside from providing rotational motion to rollers and feeders, the gearbox must also ensure that the print image is not distorted during the whole process. It must also provide easy and effective means to cut or break the transfer of motion when taking the cartridge unit out of the machine, or when clearing jammed sheets through its linkage system.

Autocompensator mechanism (ACM)

The fundamental function of the ACM is to pick and feed a single sheet of media and accurately deliver it to the downstream paper path. The pick arm is counterbalanced to provide a priming force throughout the entire range of paper levels in the tray. When media is picked, a subsequent sheet is not picked until the previous sheet's trailing edge is detected by the trailing edge sensor. Once the trailing edge of the media is detected, and the minimum interpage gap is satisfied, the next sheet will be picked.

Key components

Sensors

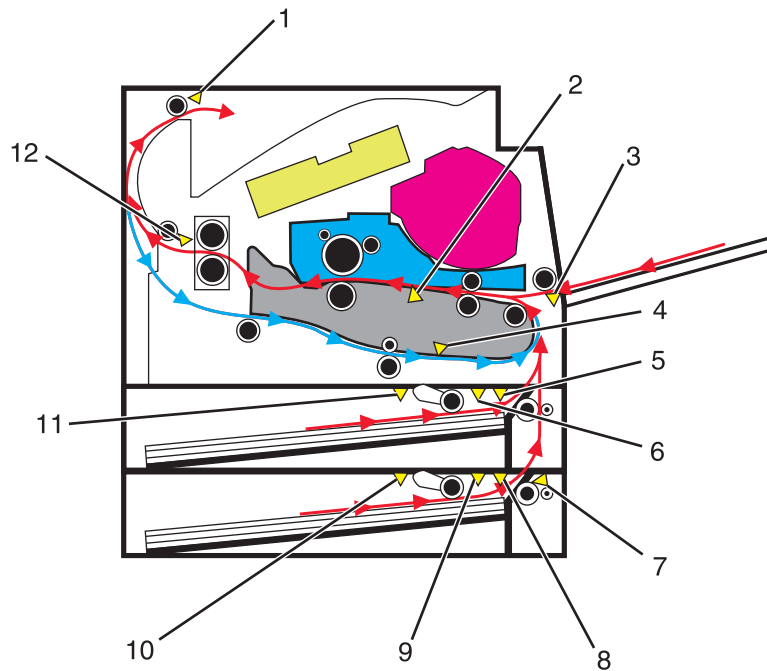

#	Part
1	Bin full sensor
2	Input sensor
3	MPF paper present sensor
4	Duplex sensor
5	Index sensor
6	Trailing edge sensor
7	Pass through sensor
8	Index sensor
9	Trailing edge sensor
10	Media present sensor
11	Media present sensor
12	Fuser exit sensor

Trailing edge sensor

Detects the media's trailing edge as it passes the pick tires. Among other capabilities, this sensor can be used to determine the paper size sensor and the media stack height.

MPF sensor

Detects the presence of media in the MPF tray.

Media present sensor

Detects the presence of media in the tray.

Tray present sensor

Detects the presence of the tray in the printer.

Bin full sensor

Detects whether the standard bin is full by moving the actuator up and down.

Toner density sensor

Detects a preplaced toner patch and image on the photoconductor (drum) and outputs pulses when the central line of the patch image aligns with the central line of the detector. The sensor outputs pulses at the timing the patch image passes the sensor. Therefore, observing changes of intervals at which pulses are output leads to toner density detection.

Pass through sensor (option tray)

Detects when the media from the option tray passes. This will trigger the pick roller to pick the next media.

Front door sensor

Is a safety switch to cut off a 24 V DC power supply from the LVPS card assembly to the HVPS card assembly, printer system card assembly and to the main drive motor assembly, while the printer front door assembly is open.

Other key components**Cooling fan**

Discharges air from the printer to prevent excessive temperature increase.

Power supply

The power supply has two main sections: the HVPS and LVPS. The HVPS card assembly generates AC power and feeds it to the developer roll, the transfer roll assembly and the charge roll assembly. The LVPS card assembly generates low voltages: 5 V DC for logic circuits, 5 V DC for laser diodes, and 24 V DC for cooling fans.

Controller board

Controls the printing operation based on the communication with the RIP controller and optional peripherals. It also controls the fuser, toner dispensing, sensor switch feedback, drive motors, clutches, and solenoids.

Rollers

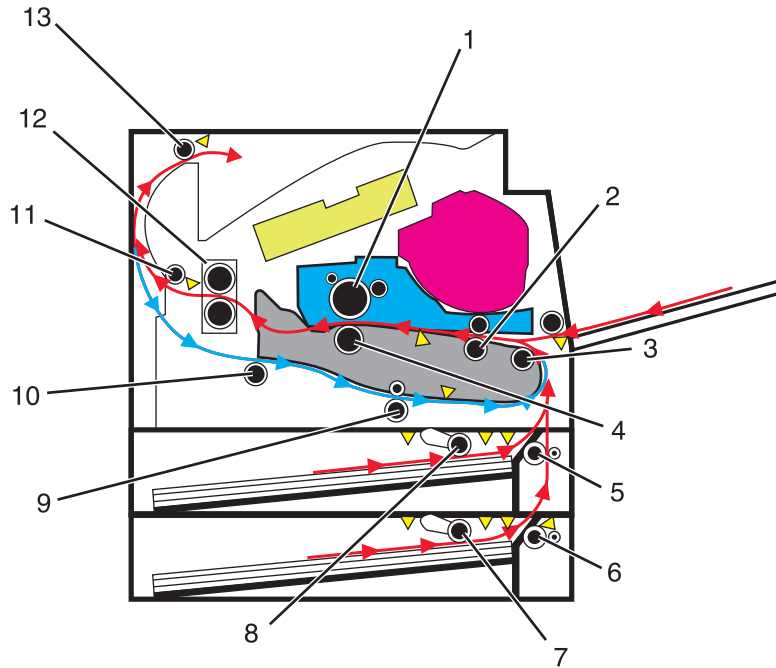

#	Part
1	Photoconductor drum
2	First input roller
3	Secondary input roller
4	Transfer roller
5	Separator roller
6	Separator roller
7	Pick rollers
8	Pick rollers
9	Duplex front deliver roller
10	Duplex rear deliver roller
11	Fuser exit roller
12	Fuser assembly
13	Paper exit roller

Electrophotographic process (EP process)

Printhead

The printhead scans the photo conductor drum surface with a laser beam. It consists of the following components:

- Laser diode (LD) card assembly
- Oscillator
- Start of scan card assembly

When a laser beam is scanned across the photoconductor drum surface from one end to the other while turning on and off the beam, one line of latent image is created. If the scanning by the laser beam is repeated while rotating the drum, a two-dimensional image is created. The resolution in the scanning direction (from right to left) is determined by the rotational speed of the printhead motor, depending on how quickly the laser is adjusted. The resolution in the process direction (from top to bottom) is determined by the rotational speed of the printhead motor. The higher the scanning speed becomes, the sooner the scanning of the next row can be started.

Step 1: Charge

During the charge step, voltage is sent from the HVPS to the charge roll beside the photoconductor. The charge roll applies a uniform negative charge over the entire surface of the photoconductor to prepare it for the laser beam.

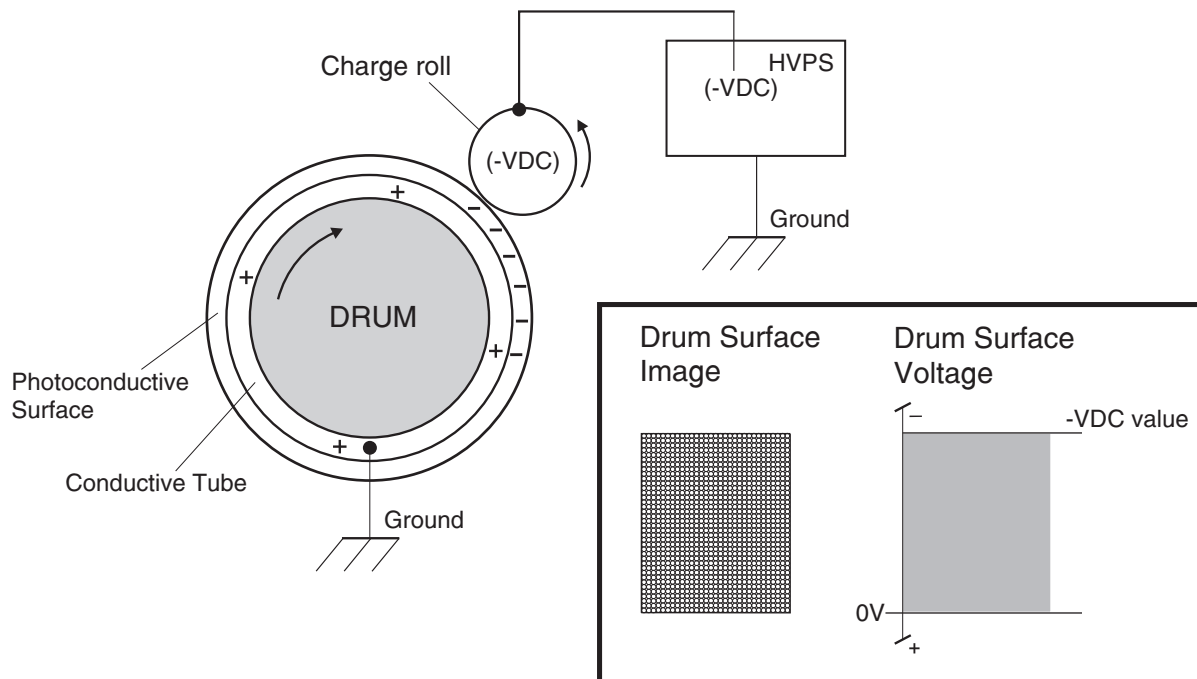

Step 2: Expose

The laser fires a focused beam of light at the surface of the photoconductor and writes an invisible image, called a latent image. The laser beam only discharges the surface where the beam hits the photoconductor. This creates a difference in charge potential between the exposed area and the rest of the photoconductor surface.

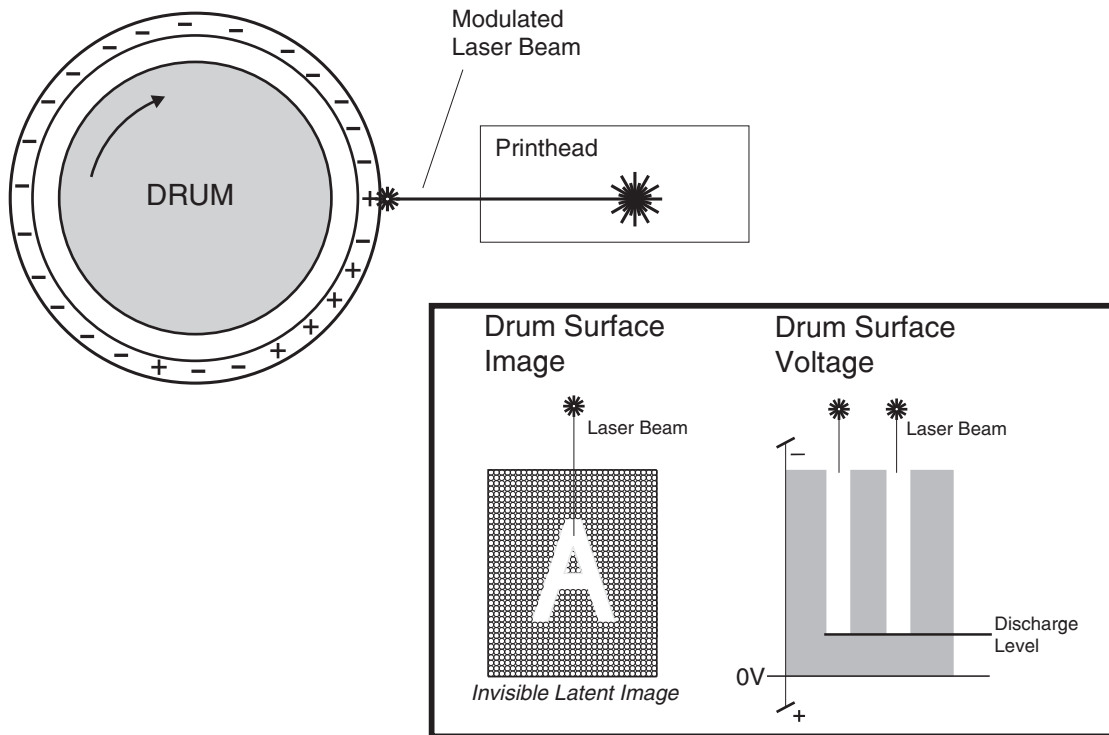

Step 3: Develop

Once the laser exposes the photoconductor, the HVPS sends charge to the developer roll. Because of the charge difference between the toner on the developer roller and the electrostatic image created by the laser, the toner is attracted to areas of the photoconductor surface exposed by the laser.

This process would be similar to using glue to write on a can and then rolling it over glitter. The glitter sticks to the glue but not to the rest of the can.

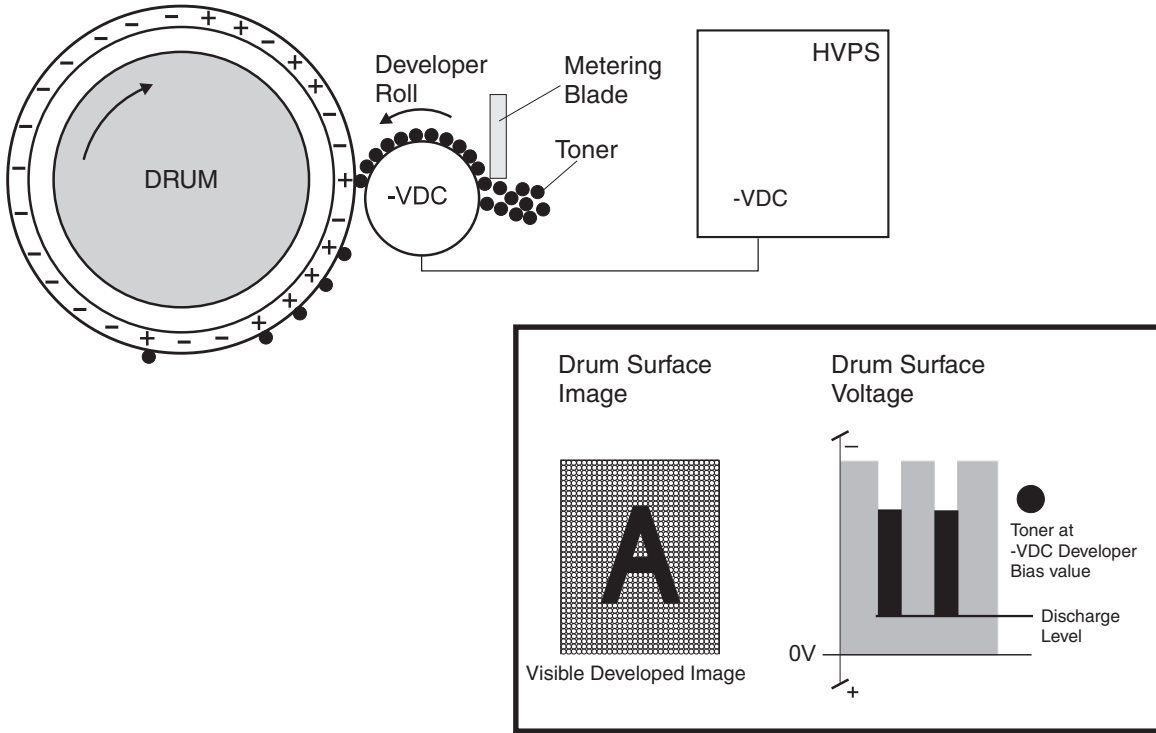

Step 4: Transfer

As the paper travels between the transfer roll and the photoconductor, the transfer roll applies a positive charge to the back of the media. This positive charge attracts the negatively charged toner image from the photoconductor to the top surface of the media.

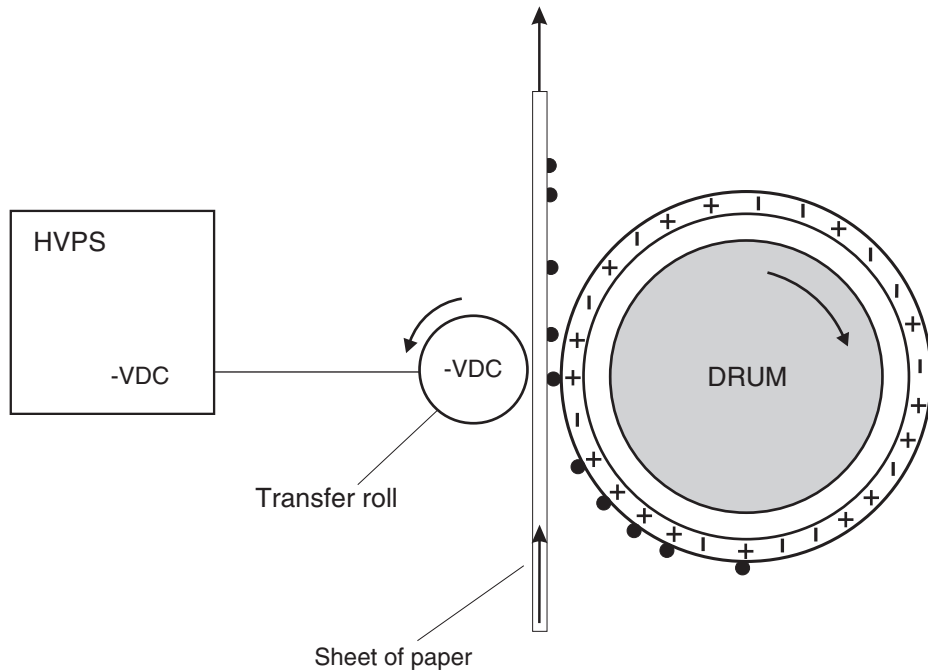

Theory of operation

Step 5: Clean

The cleaning blade removes any toner that remains on the photoconductor after the transfer process. The toner removed is collected inside the imaging unit.

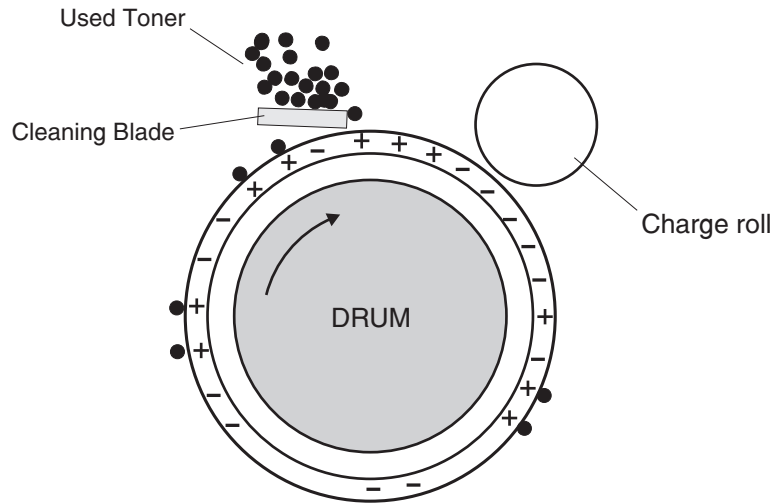

ADF theory

ADF theory of operation

ADF cross section

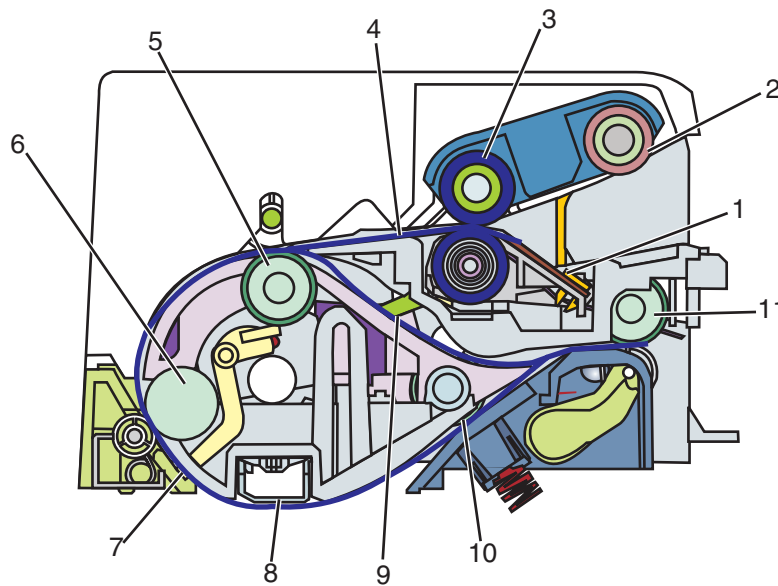

#	Part
1	Document sensor
2	Pickup roller

Theory of operation

#	Part
3	Separator roller
4	Stage and interval sensors
5	Paper feed 1 roller
6	Paper feed 2 roller
7	Feed sensor
8	Scan area
9	Duplex sensor
10	Eject 2 roll
11	Exit roller

ADF paper path

The duplex ADF enables the user to create duplex scans automatically, eliminating the need to stop the scanning process to flip the media being duplicated over. The ADF uses DC motors with encoder wheels, and a series of sensors to determine the media's position in the paper path during the scan process. The following steps are performed in creating a duplex scan on the duplex ADF:

Note: The simplex ADF uses only one motor for all paper transport functions, and does not have deskew capabilities. The scanner control unit, on the controller board receives a command to create a scan, fax, or copy.

- 1 The scanner control unit, on the controller board receives a command to create a scan, fax, or copy.
- 2 A signal is sent to the ADF to poll the document sensor (1) to check if the media to be scanned is in the correct position. The media must be placed in the ADF input tray so it actuates the document sensor. If the ADF document sensor isn't actuated, a flatbed scan is run by default.
- 3 If the media has actuated the document sensor, then an ADF scan is executed. At this point the pickup roller (2) on the pick arm assembly drops and advances the paper into the ADF. To minimize the possibility of multiple sheets being fed, a counter rotating separator roll (3) is used. After passing through pick assembly, the media actuates the stage and interval sensors (4). Actuating these sensors determines that this will be the first side of the document to be scanned.
- 4 In addition the stage sensors are used to determine and correct document skew if it is present. If the stage sensors are actuated at different times, then the paper is slowly fed to the paper feed 1 roller. The feed motor encoder wheel count tracks the paper location in the paper path.
- 5 When the paper reaches the paper feed 1 roller (5), the stationary state of the paper feed 1 roller acts as a registration roll, causing the paper to deskew.
- 6 When the encoder count reaches a certain count, the paper feed 1 roller advances the now deskewed paper to the paper feed 2 roller (6) and the feed sensor (7). If the paper does not actuate the feed sensor before a certain encoder count is attained, a paper jam error is generated.
- 7 When the feed sensor is actuated the paper advances to the scan area (8). While the paper is advancing to the scan area, the DC motor encoder generates a count which is stored in an on-board counter. These counts along with the feed sensor ensure that the media is traveling at the correct speed through the scan area. The speed the document travels through the ADF scan area is dependent on the image DPI specified by the user.

- 8** After a predetermined number of counts, the media reaches the scan area and the image acquisition process is initiated. While the image acquisition process is executing, the feed sensor is being polled to determine if the trailing edge of the media has reached the sensor.
- 9** Once the trailing edge of the scan media has reached the feed sensor, that sensor goes to the off position. After the feed sensor is switched off, the image acquisition process continues for a predetermined length of time.
- 10** When the image acquisition process is completed, the trailing edge of the media continues to the reverse point. If the scan job is simplex, then the media continues to the exit roller (11) and exits the ADF.
- 11** If the scan job is a duplex scan job, then the feed motor is reversed with a swing gear when the trailing edge of the media reaches the reverse point. A swing gear moves the diverter gate to the down position.
- 12** The reversed exit roll (11) pulls the paper back into the ADF. The eject 2 roller then moves the media to the duplex sensor. When the duplex sensor (9) is actuated, the exit roll stops. Also, the duplex sensor indicates that this is the second side of the media to be scanned.
- 13** After actuating the duplex sensor, the eject 2 roll moves the media to the paper feed 1 roll, and the feed sensor. Like the first pass of the media, the image acquisition process is repeated for the second side of the media.
- 14** When the trailing edge of the media reaches the reverse point the second time, the swing gear again moves the diverter gate to the down position and the exit roll reverses. The paper goes back into the ADF unit for a third time. The paper passes through the paper path, but no imaging occurs. This pass is to turn the paper over to the original side up. On the third pass of the media trailing edge over the reverse point, the eject two roller does not reverse and the paper passes out of the ADF.

Acronyms

Acronyms

ASIC	Application-Specific Integrated Circuit
BLDC	Brushless DC Motor
BOR	Black Only Retract
C	Cyan
CCD	Charge Coupled Device
CCP	Carbonless Copy Paper
CRC	Cyclic Redundancy Check
CSU	Customer Setup
CTLS	Capacitance Toner Level Sensing
DIMM	Dual Inline Memory Module
DRAM	Dynamic Random Access Memory
EDO	Enhanced Data Out
EP	Electrophotographic Process
EPROM	Erasable Programmable Read-Only Memory
ESD	Electrostatic Discharge
FRU	Field Replaceable Unit
GB	Gigabyte
HCF	High-Capacity Feeder
HCIT	High-Capacity Input Tray
HCOF	High-Capacity Output Finisher
HVPS	High Voltage Power Supply
ITU	Image Transfer Unit
K	Black
LCD	Liquid Crystal Display
LDAP	Lightweight Directory Access Protocol
LED	Light-Emitting Diode
LVPS	Low Voltage Power Supply
M	Magenta
MB	Megabyte
MFP	Multi-Function Printer
MPF	Multipurpose Feeder
MROM	Masked Read Only Memory

MS	Microswitch
NVM	Nonvolatile Memory
NVRAM	Nonvolatile Random Access Memory
OEM	Original Equipment Manufacturer
OPT	Optical Sensor
PC	Photoconductor
pel, pixel	Picture element
POR	Power-On Reset
POST	Power-On Self Test
PSD	Position Sensing Device
PWM	Pulse Width Modulation
RIP	Raster Imaging Processor
ROM	Read Only Memory
SDRAM	Synchronous Dual Random Access Memory
SIMM	Single Inline Memory Module
SRAM	Static Random Access Memory
TPS	Toner Patch Sensing
UPR	Used Parts Return
V ac	Volts alternating current
V dc	Volts direct current
VTB	Vacuum Transport Belt
Y	Yellow

Index

Symbols

[x]-page jam, remove all pages from the finisher's accumulator. Leave paper in bin. [45y.xx] 134
 [x]-page jam, clear manual feeder. [25y.xx] 121
 [x]-page jam, clear standard bin. [20y.xx] 91
 [x]-page jam, open automatic feeder top cover. [28y.xx] 124
 [x]-page jam, open front door. [20y.xx] 92
 [x]-page jam, open rear door. [20y.xx] 102
 [x]-page jam, open tray [1]. [241.xx] 107
 [x]-page jam, open tray [x]. [24y.xx] 112
 [x]-page jam, remove tray 1 to clear duplex. [23y.xx] 105

A

ACM, theory 532
 acronyms 543
 ADF edge erase 265
 ADF magnification 260
 ADF theory of operation 539
 ASIC test 256
 attaching cables 468
 available internal options 527
 avoiding jams 37
 avoiding paper jams 89

B

blank pages 52
 buttons, printer control panel 235
 buttons, touch screen
 using 238

C

cables
 Ethernet 468
 USB 468
 card stock
 tips 38
 Cartridge low [88.xy] 145
 Cartridge nearly low [88.xy] 146
 Cartridge very low, [x] estimated pages remain [88.xy] 146
 Cartridge, imaging unit mismatch [41.xy] 145
 Change [paper source] to [custom string] load [orientation] 146
 Change [paper source] to [custom type name] load [orientation] 146

Change [paper source] to [paper size] load [orientation] 146
 Change [paper source] to [paper type] [paper size] load [orientation] 146
 change history 25
 Check tray [x] connection 147
 cleaning
 exterior of the printer 481
 printhead lenses 483
 scanner glass 482
 cleaning the printer 481
 clipped pages or images 82
 Close flatbed cover and load originals if restarting job [2yy.xx] 147
 Close front door 147
 Complex page, some data may not have printed [39] 147
 compressed images appear on prints 84
 Configuration change, some held jobs were not restored [57] 148
 configuration menu
 A5 loading 270
 accessing 261
 action for prompts 268
 ADF edge erase 265
 automatically display error screens 272
 clear supply usage history 271
 clearing custom status 272
 conserve energy 264
 disable scanner 267
 disk encryption 269
 download emuls 263
 envelope prompts 267
 erase hard disk 273
 event log 262
 Factory Defaults 263
 fax low power support 264
 flatbed edge erase 265
 font density 269
 font sharpening 269
 format fax storage 265
 jobs on disk 268
 key repeat initial delay 271
 key repeat rate 271
 LES applications 271
 maintenance counter value 261
 menu settings page 262
 min copy memory 264

- num pad job assist 264
- Panel Menu 262
- paper prompts 267
- PPDS emulation 263
- print quality pages 262
- reduced curl 269
- require standby 270
- reset ADF maintenance kit counter 261
- reset maintenance counter 261
- restore settings 273
- safe mode 263
- scanner manual registration 265
- UI automation 270
- USB pnp 272
- USB speed 272
- wipe all settings 269, 273
- configurations
 - printer models 35
- connectors
 - controller board 469
 - power supply 477
- control panel
 - controller board, removing with 278
- control panel, printer 235
 - indicator light 235
 - Sleep button light 235
- controller board
 - control panel, removing with 278
- controller board, restoring configuration 279

D

- data security notice 43, 277
- Defective flash detected [51] 148
- device tests
 - disk test/clean 250
 - flash test 251
 - quick disk 250
- diagnostics
 - registration 240
- diagnostics menu
 - accessing 240
 - automatic darkness adjustment 254
 - base sensor test 249
 - button test 243
 - charge roll voltage 254
 - clear event log 256
 - defaults 251
 - disk test/clean 250
 - display event log 255
 - DRAM test 244
 - duplex feed 1 test 247
 - duplex left margin 246

- duplex quick test 245
- duplex sensor test 247
- duplex top margin 246
- edge to edge 252
- engine settings 252
- EP defaults 253
- exit diagnostics 260
- feed test (finisher) 249
- flash test 251
- fuser temperature 253
- gap adjust 254
- input tray feed test 247
- input tray sensor tests 248
- menu settings page 255
- output bin feed tests 248
- output bin sensor test 248
- panel test 243
- permanent page count 252
- print contrast 253
- print event log 255
- print quality pages 242
- print tests 242
- printed page count 252
- processor ID 252
- quick disk 250
- staple test 249
- transfer adjust 253
- USB HS test mode 245
- Disk full 62 148
- Disk must be formatted for use in this device 148
- display, printer control panel 235
- duplex tests
 - feed 1 test 247
 - left margin 246
 - quick test 245
 - sensor test 247
 - top margin 246

E

- Electrical specifications 523
- electrophotographic process, theory 536
- electrostatic-sensitive parts 278
- embedded solutions 284
- energy
 - conserving 264
- envelopes
 - tips 39
- environment specifications 524
- EP process, theory 536
- EP setup
 - automatic darkness adjustment 254
 - charge roll voltage 254

- EP defaults 253
 - fuser temperature 253
 - gap adjust 254
 - print contrast 253
 - transfer adjust 253
 - error codes
 - 0–99.99 160
 - 111 error messages 170
 - 121 error messages 174
 - 126 error messages 176
 - 132 error messages 177
 - 133 error messages 178
 - 140 error messages 179
 - 146 error messages 180
 - 155 error messages 181
 - 171 error messages 182
 - 200 paper jam messages 95
 - 201 paper jam messages 101
 - 202 paper jam messages 103
 - 23y paper jam messages 106
 - 241 paper jam messages 108
 - 242 paper jam messages 114
 - 243 paper jam messages 116
 - 244 paper jam messages 118
 - 25y paper jam messages 122
 - 321 error messages 219
 - 322 error messages 220
 - 324 error messages 220
 - 325 error messages 220
 - 331 error messages 220
 - 332 error messages 220
 - 334 error messages 221
 - 335 error messages 221
 - 341 error messages 221
 - 342 error messages 221
 - 344 error messages 221
 - 381 error messages 224
 - 451 error messages 137
 - 452 error messages 138
 - 453 error messages 138
 - 454 error messages 138
 - 456 error messages 138
 - 457 error messages 139
 - 900 error messages 185
 - 912 error messages 188
 - 94y error messages 189
 - 950–958 error messages 189
 - 959 error messages 192
 - 96y error messages 193
 - 97y error messages 194
 - 98y error messages 195
 - 99y error messages 196
 - Error reading USB drive. Remove USB. 148
 - Error reading USB hub. Remove hub. 148
 - ESD-sensitive parts 278
 - eSF solutions 284
 - Ethernet port 468
 - event log
 - print log 255
 - exterior of the printer
 - cleaning 481
- ## F
- fax error log codes 214
 - fax issue, escalating 218
 - Fax memory full 149
 - Fax partition inoperative. Contact system administrator. 149
 - fax ports 468
 - Fax server 'To Format' not set up. Contact system administrator. 149
 - fax service engineer (SE) menu 276
 - fax specifications 525
 - Fax Station Name not set up. Contact system administrator. 149
 - Fax Station Number not set up. Contact system administrator. 149
 - feed test 257
 - fine lines are not printed correctly 81
 - finisher tests
 - feed test (finisher) 249
 - sensor test 249
 - staple test 249
 - flatbed edge erase 265
 - folded or wrinkled paper 64
 - format fax storage 265
- ## H
- hardware tests
 - button test 243
 - DRAM test 244
 - panel test 243
 - USB HS test mode 245
 - home screen buttons and icons
 - description 236
 - horizontal bottom contact connector 289
 - horizontal light bands 72
 - horizontal sliding contact connector 295
 - horizontal top contact connector 286
- ## I
- Imaging unit low [84.xy] 149
 - Imaging unit nearly low [84.xy] 149

Imaging unit very low, [x] estimated pages remain [84.xy] 149

in finisher rear door
 paper jams, clearing 129, 134

Incompatible tray [x] [59] 150

incorrect margins on prints 85

Incorrect paper size, open [paper source] [34] 150

input tray tests
 feed tests 247
 sensor tests 248

input tray, theory 529

inspection guide 479

Insufficient memory for Flash Memory Defragment operation [37] 150

Insufficient memory to collate job [37] 150

Insufficient memory to support Resource Save feature [35] 151

Insufficient memory, some Held Jobs were deleted [37] 150

Insufficient memory, some held jobs will not be restored [37] 150

invalid code, fixing 273

invalid engine mode
 accessing 273

J

jams
 accessing 90
 avoiding 89
 understanding messages 90

jams, clearing
 finisher bin 129
 in automatic document feeder top cover 124
 in duplex area 105
 in front door 92
 in manual feeder 121
 in rear door 102
 in standard bin 91
 in staple access door 129
 in stapler door 134
 in tray [1] 107
 in tray [x] 112

L

labels, paper
 tips 39

letterhead
 tips on using 40

light, indicator 235

Load [paper source] with [custom string] [paper orientation] 151

Load [paper source] with [custom type name] [paper orientation] 151

Load [paper source] with [paper size] [paper orientation] 151

Load [paper source] with [paper type] [paper size] [paper orientation] 152

Load Manual Feeder with [custom string] [paper orientation] 152

Load Manual Feeder with [custom type name] [paper orientation] 152

Load Manual Feeder with [paper size] [paper orientation] 152

Load manual feeder with [paper type] [paper size] [paper orientation] 152

low insertion force (LIF) connector 298

LSU adjustment 395

lubrication
 guidelines 481

M

main drive gearbox, theory 532

maintenance counter 480

maintenance kit
 resetting the counter 480

Maintenance kit low [80.xy] 153

Maintenance kit nearly low [80.xy] 153

Maintenance kit very low, [x] estimated pages remain [80.xy] 153

maintenance kits 480

Memory full [38] 153

Memory full, cannot print faxes 153

Memory full, cannot send faxes 153

menus
 list of 239

min copy memory 264

motor tests 256

MPF, theory 530

N

Network [x] software error [54] 153

network SE menu
 accessing 275

No analog phone line connected to modem, fax is disabled. 154

Non-Lexmark [supply type], see User's Guide [33.xy] 154

Not enough free space in flash memory for resources [52] 154

num pad job assist 264

O

operating clearances 523
 options
 media handling options 527
 memory cards 527
 output bin tests
 feed tests 248
 sensor test 248

P

Panel Menus 262
 paper
 characteristics 35
 letterhead 37
 preprinted forms 37
 recycled 38
 selecting 37
 storing 37
 unacceptable 36
 Paper changes needed 154
 paper curl 62
 paper jams
 280 125
 281 125
 282 125
 283 125
 29y 128
 avoiding 89
 paper jams, clearing
 finisher bin 129
 in automatic document feeder top cover 124
 in duplex area 105
 in finisher rear door 129, 134
 in front door 92
 in manual feeder 121
 in rear door 102
 in standard bin 91
 in staple access door 129
 in stapler door 134
 in tray [1] 107
 in tray [x] 112
 paper sizes
 supported 40
 paper types
 supported by printer 42
 where to load 42
 paper weights
 supported by printer 42
 Parallel port [x] disabled [56] 155
 parts catalog legend 484
 POR sequence 46
 power-on reset sequence 46
 print is too dark 58
 print is too light 60
 print quality
 cleaning the scanner glass 482
 initial check 49
 print quality troubleshooting
 840.xx service check 198
 ADF cover open service check 128
 ADF duplex service check 204
 ADF feed errors service check 205
 ADF paper jam service check 125
 ADF streak service check 208
 black or blank page copy service check 206
 blank pages 52
 CCD service check 199
 clipped pages or images 82
 compressed images appear on prints 84
 fax reception service check 211
 fax transmission service check 209
 fine lines are not printed correctly 81
 flatbed home position service check 200
 flatbed motor service check 214
 folded or wrinkled paper 64
 gray background on prints 50
 horizontal light bands 72
 incorrect margins on prints 85
 modem/fax card service check 207
 paper curl 62
 print is too dark 58
 print is too light 60
 repeating defects 68
 skewed print 69
 solid black pages 65
 streaked vertical lines appear on prints 71
 toner rubs off 86
 toner specks appear on prints 87
 vertical dark bands 75
 vertical dark streaks with print missing 76
 vertical light bands 74
 white streaks and voided areas 78
 printer
 basic model 467
 fully configured 467
 printer configurations 467
 printer control panel 235
 indicator light 235
 Sleep button light 235
 Printer had to restart. Last job may be incomplete. 155

- printer messages
- [x]-page jam, remove all pages from the finisher's accumulator. Leave paper in bin. [45y.xx] 134
 - [x]-page jam, remove all pages from the output bin. Leave paper in bin. [45y.xx] 129
 - [x]-page jam, clear manual feeder. [25y.xx] 121
 - [x]-page jam, clear standard bin. [20y.xx] 91
 - [x]-page jam, open automatic feeder top cover. [28y.xx] 124
 - [x]-page jam, open front door. [20y.xx] 92
 - [x]-page jam, open rear door. [20y.xx] 102
 - [x]-page jam, open tray [1]. [241.xx] 107
 - [x]-page jam, open tray [x]. [24y.xx] 112
 - [x]-page jam, remove tray 1 to clear duplex. [23y.xx] 105
 - Cartridge low [88.xy] 145
 - Cartridge nearly low [88.xy] 146
 - Cartridge very low, [x] estimated pages remain [88.xy] 146
 - Cartridge, imaging unit mismatch [41.xy] 145
 - Change [paper source] to [custom string] load [orientation] 146
 - Change [paper source] to [custom type name] load [orientation] 146
 - Change [paper source] to [paper size] load [orientation] 146
 - Change [paper source] to [paper type] [paper size] load [orientation] 146
 - Check tray [x] connection 147
 - Close flatbed cover and load originals if restarting job [2yy.xx] 147
 - Close front door 147
 - Complex page, some data may not have printed [39] 147
 - Configuration change, some held jobs were not restored [57] 148
 - Defective flash detected [51] 148
 - Disk full 62 148
 - Disk must be formatted for use in this device 148
 - Disk near full. Securely clearing disk space. 148
 - Error reading USB drive. Remove USB. 148
 - Error reading USB hub. Remove hub. 148
 - Fax memory full 149
 - Fax partition inoperative. Contact system administrator. 149
 - Fax server 'To Format' not set up. Contact system administrator. 149
 - Fax Station Name not set up. Contact system administrator. 149
 - Fax Station Number not set up. Contact system administrator. 149
 - Imaging unit low [84.xy] 149
 - Imaging unit nearly low [84.xy] 149
 - Imaging unit very low, [x] estimated pages remain [84.xy] 149
 - Incompatible tray [x] [59] 150
 - Incorrect paper size, open [paper source] [34] 150
 - Insufficient memory for Flash Memory Defragment operation [37] 150
 - Insufficient memory to collate job [37] 150
 - Insufficient memory to support Resource Save feature [35] 151
 - Insufficient memory, some Held Jobs were deleted [37] 150
 - Insufficient memory, some held jobs will not be restored [37] 150
 - Load [paper source] with [custom string] [paper orientation] 151
 - Load [paper source] with [custom type name] [paper orientation] 151
 - Load [paper source] with [paper size] [paper orientation] 151
 - Load [paper source] with [paper type] [paper size] [paper orientation] 152
 - Load Manual Feeder with [custom string] [paper orientation] 152
 - Load Manual Feeder with [custom type name] [paper orientation] 152
 - Load Manual Feeder with [paper size] [paper orientation] 152
 - Load manual feeder with [paper type] [paper size] [paper orientation] 152
 - Maintenance kit low [80.xy] 153
 - Maintenance kit nearly low [80.xy] 153
 - Maintenance kit very low, [x] estimated pages remain [80.xy] 153
 - Memory full [38] 153
 - Memory full, cannot print faxes 153
 - Memory full, cannot send faxes 153
 - Network [x] software error [54] 153
 - No analog phone line connected to modem, fax is disabled. 154
 - Non-Lexmark [supply type], see User's Guide [33.xy] 154
 - Not enough free space in flash memory for resources [52] 154
 - Paper changes needed 154
 - Parallel port [x] disabled [56] 155
 - Printer had to restart. Last job may be incomplete. 155
 - Reinstall missing or unresponsive cartridge [31.xy] 156
 - Reinstall missing or unresponsive imaging unit [31.xy] 156

- Remove defective disk [61] 155
 - Remove paper from standard output bin 155
 - Replace all originals if restarting job. 156
 - Replace cartridge, 0 estimated pages remain [88.xy] 155
 - Replace defective imaging unit [31.xy] 155
 - Replace imaging unit, 0 estimated pages remain [84.xy] 155
 - Replace maintenance kit, 0 estimated pages remain [80.xy] 155
 - Replace unsupported cartridge [32.xy] 156
 - Replace unsupported imaging unit [32.xy] 156
 - Restore held jobs? 157
 - Scanner automatic feeder cover open 157
 - Scanner disabled by admin [840.01] 157
 - Scanner disabled. Contact system administrator if problem persists. [840.02] 157
 - Scanner jam, remove all originals from the scanner [2yy.xx] 157
 - Scanner jam, remove jammed originals from the scanner [2yy.xx] 157
 - Serial port [x] disabled [56] 157
 - SMTP server not set up. Contact system administrator. 157
 - Some held jobs were not restored 158
 - Standard network software error [54] 158
 - Standard USB port disabled [56] 158
 - Supply needed to complete job 158
 - Too many flash options installed [58] 158
 - Too many trays attached [58] 158
 - Unformatted flash detected [53] 159
 - Unsupported disk 159
 - Unsupported option in slot [x] [55] 159
 - Unsupported USB hub, please remove 148
 - USB port [x] disabled [56] 159
 - Weblink server not set up. Contact system administrator. 159
 - printer models
 - configurations 35
 - printer setup
 - defaults 251
 - edge to edge 252
 - permanent page count 252
 - printed page count 252
 - printhead adjustment 395
 - printhead lenses
 - cleaning 483
- R**
- recovery mode
 - accessing 274
 - recycled paper
 - using 38
 - registration 240
 - Reinstall missing or unresponsive cartridge [31.xy] 156
 - Reinstall missing or unresponsive imaging unit [31.xy] 156
 - removal procedures
 - tips 302
 - removals
 - accumulator assembly 462
 - ACM assembly 369
 - ACM assembly, option tray 418
 - adf cable 408
 - adf input tray 402
 - ADF left hinge 411
 - ADF right hinge 411
 - ADF separator roll 399
 - ADF top cover assembly 407
 - adf unit 402
 - bail 353
 - bin full sensor 392
 - bin full sensor cable 394
 - cartridge gearbox 312
 - cartridge plunger 331
 - cave light lens 343
 - control panel assembly 336
 - control panel cover 345
 - control panel ribbon cable 412
 - controller board 320
 - controller board shield 322
 - cooling fan 319
 - display 346
 - diverter cover 390
 - diverter gearbox 459
 - diverter spring 389
 - duplex 362
 - duplex gear assembly 313
 - duplex sensor and input sensor 363
 - dust cover 381
 - flatbed assembly 412
 - flatbed cushion 400
 - front access cover 354
 - front access sensor 356
 - front bin cover 335
 - front input guide 356
 - fuser 386
 - index sensor 366
 - interface card 344
 - jam access cover 353
 - keypad assembly 348
 - laser scanning unit (LSU) 395

- left cover 302
- left front mount 327
- lens 392
- main drive gearbox 304
- media present sensor 366
- media present sensor flag 374
- memory access door 318
- modem 326
- MPF gearbox 308
- MPF pick tire 352
- MPF pick tire cover 352
- MPF sensor 356
- MPF solenoid 306
- MPF tray 349
- name plate cover 333
- pick roller 415
- Pick/lift motor gearbox 371
- power supply 361
- power supply shield 361
- rear cover 382
- rear exit door 381
- redrive assembly 383
- redrive shaft 384
- restraint pad 414
- reverse solenoid 311
- right cover 315
- right front mount 328
- scanner assembly 405
- scanner front cover 401
- sensor (stapler access door) 427
- sensor (stapler bin full receive) 448
- sensor (stapler bin full send) 450
- sensor (stapler left tamper HP) 463
- sensor (stapler paddle HP) 464
- sensor (stapler pass through) 453
- sensor (stapler rear cover) 434
- sensor (stapler right tamper HP) 462
- sensor (toner density) 374
- separator pad 358
- separator roll assembly 416
- speaker 342
- speaker cable 412
- staple finisher option 421
- staple roll holder 423
- stapler cable 387
- stapler carriage assembly 427
- stapler cartridge access door 422
- stapler controller card 437
- stapler cooling fan 441
- stapler door close limit switch 429
- stapler interface cable 443
- stapler left cover 425
- stapler left tamper motor 437
- stapler paddle motor 433
- stapler power supply unit 441
- stapler rear cover 433
- stapler rear cover close limit switch 439
- stapler rear door 426
- stapler right cover 424
- stapler right tamper motor 438
- stapler service cover 437
- stapler top cover 445
- tamper drive belt 458
- tamper main assembly 455
- tamper sub-assembly 456
- toner cartridge smart chip contact 324
- top cover 391
- trailing edge sensor 368
- transfer roll 330
- trapped staple access door 436
- tray guide 372
- tray present sensor 318
- UICC 340
- USB cable 409
- USB cable bracket 342
- USB wireless cable 410
- remove all pages from the output bin. Leave paper in bin. [45y.xx] 129
- Remove defective disk [61] 155
- Remove paper from standard output bin 155
- Replace all originals if restarting job. 156
- Replace cartridge, 0 estimated pages remain [88.xy] 155
- Replace defective imaging unit [31.xy] 155
- Replace imaging unit, 0 estimated pages remain [84.xy] 155
- Replace maintenance kit, 0 estimated pages remain [80.xy] 155
- Replace unsupported cartridge [32.xy] 156
- Replace unsupported imaging unit [32.xy] 156
- reports
 - event log 262
 - menu settings page 262
- resetting the printer
 - without admin credentials 47
- Restore held jobs? 157
- restore point
 - accessing 274
- restoring
 - configuration file 282
 - license file 282

S

safe mode 46

- Scanner automatic feeder cover open 157
 - Scanner calibration
 - menu settings page 241
 - scanner calibration reset 260
 - Scanner configuration 264
 - Scanner disabled by admin [840.01] 157
 - Scanner disabled. Contact system administrator if problem persists. [840.02] 157
 - scanner glass
 - cleaning 482
 - Scanner jam, remove all originals from the scanner [2yy.xx] 157
 - Scanner jam, remove jammed originals from the scanner [2yy.xx] 157
 - scanner manual registration 265
 - scanner specifications 524
 - scanner tests
 - ADF magnification 260
 - ASIC 256
 - feed test 257
 - motor tests 256
 - scanner calibration reset 260
 - sensor tests 257
 - scheduled maintenance 480
 - security reset jumper
 - using 47
 - security slot 468
 - selecting paper 37
 - sensor tests 257
 - Serial port [x] disabled [56] 157
 - serial wrap test 244
 - service checks troubleshooting
 - 8yy service error messages 197
 - network service check 231
 - service engineer (SE) menu 276
 - accessing 276
 - SMTP server not set up. Contact system administrator. 157
 - solid black pages 65
 - Some held jobs were not restored 158
 - Specifications
 - electrical 523
 - specifications
 - acoustics 524
 - environment 524
 - fax 525
 - operating clearances 523
 - scanner 524
 - Standard network software error [54] 158
 - Standard USB port disabled [56] 158
 - storing
 - paper 37
 - streaked vertical lines appear on prints 71
 - Supply needed to complete job 158
 - supported paper sizes 40
 - symptoms
 - printer 224
- ## T
- theory of operation
 - ACM 532
 - duplex printing 531
 - electrophotographic process 536
 - input tray 529
 - main drive gearbox 532
 - MPF 530
 - other key components 534
 - POR sequence 529
 - printer control 529
 - sensors 533
 - simplex printing 530
 - tips
 - card stock 38
 - envelopes 39
 - labels, paper 39
 - letterhead 40
 - transparencies 40
 - toner rubs off 86
 - toner specks appear on prints 87
 - Too many flash options installed [58] 158
 - Too many trays attached [58] 158
 - tools, required 43
 - touch screen
 - buttons 238
 - transparencies
 - tips 40
 - troubleshooting
 - initial check 45
 - scan/fax/copy symptoms 203
 - troubleshooting, print quality
 - 840.xx service check 198
 - ADF cover open service check 128
 - ADF duplex service check 204
 - ADF feed errors service check 205
 - ADF paper jam service check 125
 - ADF streak service check 208
 - black or blank page copy service check 206
 - blank pages 52
 - CCD service check 199
 - clipped pages or images 82
 - compressed images appear on prints 84
 - fax reception service check 211
 - fax transmission service check 209
 - fine lines are not printed correctly 81

- flatbed home position service check 200
- flatbed motor service check 214
- folded or wrinkled paper 64
- gray background on prints 50
- horizontal light bands 72
- incorrect margins on prints 85
- modem/fax card service check 207
- paper curl 62
- print is too dark 58
- print is too light 60
- repeating defects 68
- skewed print 69
- solid black pages 65
- streaked vertical lines appear on prints 71
- toner rubs off 86
- toner specks appear on prints 87
- vertical dark bands 75
- vertical dark streaks with print missing 76
- vertical light bands 74
- white streaks and voided areas 78
- troubleshooting, service checks
 - 8yy service error messages 197
 - network service check 231

U

- unacceptable paper 36
- understanding the home screen buttons and icons 236
- Unformatted flash detected [53] 159
- Unsupported option in slot [x] [55] 159
- Unsupported USB hub, please remove 148
- updating the printer firmware
 - using a flash drive 283
 - using a network computer 283
- USB port 468
- USB port [x] disabled [56] 159
- using the touch-screen buttons 238

V

- vertical dark bands 75
- vertical dark streaks with print missing 76
- vertical mount contact connector 292

W

- Weblink server not set up. Contact system administrator. 159
- white streaks and voided areas 78

Z

- zero insertion force (ZIF) connectors 285

Part number index

P/N	Part name	Page
40X0269	Power cord, 2.5 m (straight)—USA, Canada.....	519
40X0270	Power cord, 2.5 m (straight)—Japan.....	519
40X0271	Power cord, 2.5 m (straight)—United Kingdom.....	519
40X0273	Power cord, 2.5 m (straight)—Traditional Italy.....	519
40X0275	Power cord, 2.5 m (straight)—Israel.....	519
40X0288	Power cord, 2.5 m (straight)—Argentina.....	519
40X0301	Power cord, 2.5 m (straight)—Australia.....	519
40X0303	Power cord, 2.5 m (straight)—China.....	519
40X1368	USB cable, packaged (2 meters).....	521
40X1772	Power cord, 2.5 m (straight)—Switzerland.....	519
40X1773	Power cord, 2.5 m (straight)—South Africa.....	519
40X1774	Power cord, 2.5 m (straight)—Denmark.....	519
40X1791	Power cord, 2.5 m (straight)—Taiwan.....	519
40X1792	Power cord, 2.5 m (straight)—Korea.....	519
40X3141	Power cord, 2.5 m (straight)—Europe and others.....	519
40X4596	Power cord, 2.5 m (straight)—Brazil.....	519
40X4819	Adapter, RS232C serial.....	521
40X4823	Adapter, parallel 1284-B THCK.....	521
40X4826	Adapter, N8120 GB INA.....	521
40X5315	Screw, shipped with ISP (2PER).....	521
40X5316	Cable, 14-pin JST- for ISP.....	521
40X5317	Standoff, tee with thumbscrew.....	521
40X5804	Flatbed cushion (legal).....	488
40X7445	2GB DDR3 DIMM.....	521
40X7546	ADF right hinge.....	488
40X7567	1GB DDR3 DIMM.....	521
40X7592	Media present sensor.....	496
40X7592	Sensor (stapler access door).....	506
40X7592	Tray present sensor.....	492
40X7592	Sensor (stapler rear door).....	510
40X7797	Power supply, 100 V/110 V.....	496
40X7798	Power supply, 220 V	496

P/N	Part name	Page
40X7854	Fax card.....	492
40X7856	Hard disk drive (ATA pass through).....	521
40X7858	Adapter, 802.11B/G/N - US.....	521
40X8023	Fuser, 110 V.....	492
40X8024	Fuser, 220 V.....	492
40X8043	Duplex sensor and input sensor.....	496
40X8044	Index sensor.....	496
40X8045	Trailing edge sensor.....	496
40X8048	Front door sensor.....	496
40X8079	Galvo LSU*.....	492
40X8083	Cartridge gearbox.....	499
40X8084	ACM liftplate gearbox.....	499
40X8085	Main drive gearbox.....	499
40X8086	550-sheet tray insert.....	486
40X8121	Staple finisher option.....	504
40X8125	Stapler tamper motor.....	508, 514
40X8128	Stapler rear door.....	510
40X8129	Stapler cartridge access door.....	506
40X8130	Stapler right cover.....	506
40X8131	Sensor (stapler bin full send).....	508
40X8132	Sensor (stapler bin full receive).....	508
40X8134	Sensor (stapler pass through).....	510
40X8135	Stapler power supply unit.....	510
40X8137	Stapler controller card.....	508
40X8138	Stapler rear door close limit switch with cable.....	510
40X8139	Stapler door close limit switch with cable.....	506
40X8140	Stapler service cover.....	508
40X8141	Stapler top cover.....	508
40X8142	Stapler carriage assembly.....	506
40X8144	Stapler interface cable.....	506
40X8148	Stapler cooling fan.....	510
40X8149	Staple roll holder.....	506
40X8262	ACM assembly (option tray only).....	502
40X8266	Cartridge smart chip contact	496

P/N	Part name	Page
40X8275	Duplex assembly.....	499
40X8277	Duplex gear assembly.....	499
40X8279	Jam access cover.....	499
40X8280	Front input guide.....	492
40X8286	550-sheet tray.....	502
40X8287	250-sheet tray.....	502
40X8295	MPF pick roller and separator pad.....	499
40X8299	Front mounts.....	499
40X8300	MPF solenoid.....	492
40X8301	Reverse solenoid.....	492
40X8343	Fuser, 100 V.....	492
40X8393	Transfer roll.....	499
40X8443	Pick roller assembly.....	502
40X8444	Separator roll assembly.....	486, 502
40X8458	Trapped staple access door.....	510
40X8520	Dust cover, 250-sheet tray.....	502
40X8521	Dust cover, 550-sheet tray.....	502
40X8523	RS-232C Serial Interface Card.....	521
40X8524	Parallel 1284-B interface card.....	521
40X8525	Adapter, fiber ISP.....	521
40X8526	MarkNet N8350 802.11 b/g/n Wireless Print Server.....	521
40X8528	250-sheet tray insert (option tray only).....	502
40X8529	550-sheet tray insert (option tray only).....	502
40X8540	Stapler power supply unit—China.....	510
40X8556	Font card, Traditional Chinese.....	521
40X8557	Font card, Simplified Chinese.....	521
40X8568	Font card, Korean.....	521
40X8569	Font card, Japanese.....	521
40X8570	Font card, Arabic.....	521
40X8571	Font card, Hebrew.....	521
40X8657	IPDS card.....	521
40X8700	Relocation kit.....	522
40X8736	ADF pick roll.....	488
40X8748	Stapler tamper main assembly.....	512

P/N	Part name	Page
40X8749	Tamper sub-assembly.....	514
40X8750	Stapler tamper drive belt.....	514
40X8751	Stapler accumulator assembly.....	512
40X8752	Stapler diverter gearbox.....	516
40X8753	Stapler paddle motor.....	516
40X8754	Sensor (stapler left tamper HP).....	514
40X8754	Sensor (stapler paddle HP).....	514
40X8754	Sensor (stapler right tamper HP).....	514
40X8777	MPF gearbox.....	499
40X8850	Redrive shaft.....	499
40X9050	MPF wireless cable.....	488
0		
40X9051	MPF USB cable	488
40X9052	UICC cable.....	490
40X9053	USB cable bracket.....	488
40X9054	ADF input tray.....	488
40X9068	Front access cover (MPF).....	486
40X9079	Speaker	488
40X9080	Speaker cable.....	488
0		
40X9082	Redrive assembly.....	499
40X9084	Diverter cover.....	486
40X9086	Left cover.....	486
40X9087	Rear cover.....	486
40X9088	Cave light lens.....	488
40X9090	Right cover.....	486
0		
40X9093	ADF assembly.....	488
40X9094	Flatbed.....	488
40X9095	Front bin cover.....	486
5		
40X9096	Exit rear door.....	486
6		
40X9097	Scanner front cover.....	488
40X9098	Stapler diverter spring.....	499

P/N	Part name	Page
40X909 9	Top cover.....	486
40X9100	Memory access door (MFP)	486
40X9101	Name plate cover.....	486
40X9102	Output expander.....	486
40X9110	Restraint pad.....	488
40X9116	Stapler cable.....	499
40X9117	High end ADF cable.....	488
40X9125	Control panel cover (MX610de).....	490
40X9126	Bin full sensor cable.....	492
40X9127	IR sensor lens.....	492
40X9129	ADF left hinge.....	488
40X9131	MPF tray cover.....	486
40X9132	Control panel cover (MX611de and XM3150).....	490
40X9133	Control panel cover (MX611dhe).....	490
40X9137	Maintenance kit, 110 V.....	517
40X9138	Maintenance kit, 220 V.....	517
40X9142	ADF top cover (legal)	488
40X9147	Maintenance kit, 100 V.....	517
40X9148	Cartridge plunger.....	486
40X9181	Cooling fan.....	492
40X9254	Controller board* (galvo LSU).....	492
40X9523	Tray guide.....	499
40X9646	Bin full sensor.....	492
40X9652	Adapter, N8130 10/100 fiber.....	521
40X9654	550-sheet tray, lockable.....	502
40X9879	Smart card reader.....	522
41X0259	Narrow media sensor.....	492
41X0362	Polygon LSU*.....	492
41X0363	Polygon laser scanning unit (LSU) frame*.....	492
41X0485	Controller board* (polygon LSU).....	492
41X0568	MarkNet N8350 802.11 b/g/n Wireless Print Server with NFC.....	521
41X0756	Control panel assembly.....	490
41X0759	Polygon LSU cable*.....	492

P/N	Part name	Page
41X0866	Forms and Bar code card.....	521
41X0868	Prescribe card.....	521
41X0913	Video cable (galvo LSU).....	492
41X0917	ADF separator roller.....	488
41X0958	Pick tire.....	499
41X0959	ACM assembly (standard tray only).....	499
41X0994	MPF tray links.....	486
41X1946	N8230 Fiber ISP with Backpack	521
41X2018	Control panel cover (MX617de).....	490
41X2300	Access cover link.....	486
41X4453	Paper present sensor flag kit.....	496
41X4456	Toner density sensor kit.....	496

Part name index

P/N	Part name	Page
40X7567	1GB DDR3 DIMM.....	521
40X8287	250-sheet tray.....	502
40X8528	250-sheet tray insert (option tray only).....	502
40X7445	2GB DDR3 DIMM.....	521
40X8286	550-sheet tray.....	502
40X8529	550-sheet tray insert (option tray only).....	502
40X9654	550-sheet tray, lockable.....	502
40X8086	550-sheet tray insert.....	486
41X2300	Access cover link.....	486
40X8262	ACM assembly (option tray only).....	502
41X0959	ACM assembly (standard tray only).....	499
40X8084	ACM liftplate gearbox.....	499
40X7858	Adapter, 802.11B/G/N - US.....	521
40X8525	Adapter, fiber ISP.....	521
40X4826	Adapter, N8120 GB INA.....	521
40X9652	Adapter, N8130 10/100 fiber.....	521
40X4823	Adapter, parallel 1284-B THCK.....	521
40X4819	Adapter, RS232C serial.....	521
40X9093	ADF assembly.....	488
40X9054	ADF input tray.....	488
40X9129	ADF left hinge.....	488
40X8736	ADF pick roll.....	488
40X7546	ADF right hinge.....	488
41X0917	ADF separator roller.....	488
40X9142	ADF top cover (legal)	488
40X9646	Bin full sensor.....	492
40X9126	Bin full sensor cable.....	492
40X5316	Cable, 14-pin JST- for ISP.....	521
40X8083	Cartridge gearbox.....	499
40X9148	Cartridge plunger.....	486
40X8266	Cartridge smart chip contact	496
40X9088	Cave light lens.....	488

P/N	Part name	Page
41X0756	Control panel assembly.....	490
40X9125	Control panel cover (MX610de).....	490
40X9132	Control panel cover (MX611de and XM3150).....	490
40X9133	Control panel cover (MX611dhe).....	490
41X2018	Control panel cover (MX617de).....	490
40X9254	Controller board* (galvo LSU).....	492
41X0485	Controller board* (polygon LSU).....	492
40X9181	Cooling fan.....	492
40X9084	Diverter cover.....	486
40X8275	Duplex assembly.....	499
40X8277	Duplex gear assembly.....	499
40X8043	Duplex sensor and input sensor.....	496
40X8520	Dust cover, 250-sheet tray.....	502
40X8521	Dust cover, 550-sheet tray.....	502
40X9096	Exit rear door.....	486
40X7854	Fax card.....	492
40X9094	Flatbed.....	488
40X5804	Flatbed cushion (legal).....	488
40X8570	Font card, Arabic.....	521
40X8571	Font card, Hebrew.....	521
40X8569	Font card, Japanese.....	521
40X8568	Font card, Korean.....	521
40X8557	Font card, Simplified Chinese.....	521
40X8556	Font card, Traditional Chinese.....	521
41X0866	Forms and Bar code card.....	521
40X9068	Front access cover (MPF).....	486
40X9095	Front bin cover.....	486
40X8048	Front door sensor.....	496
40X8280	Front input guide.....	492
40X8299	Front mounts.....	499
40X8343	Fuser, 100 V.....	492
40X8023	Fuser, 110 V.....	492
40X8024	Fuser, 220 V.....	492
40X8079	Galvo LSU*.....	492

P/N	Part name	Page
40X7856	Hard disk drive (ATA pass through).....	521
40X9117	High end ADF cable.....	488
40X8044	Index sensor.....	496
40X8657	IPDS card.....	521
40X9127	IR sensor lens.....	492
40X8279	Jam access cover.....	499
40X9086	Left cover.....	486
40X8085	Main drive gearbox.....	499
40X9147	Maintenance kit, 100 V.....	517
40X9137	Maintenance kit, 110 V.....	517
40X9138	Maintenance kit, 220 V.....	517
40X8526	MarkNet N8350 802.11 b/g/n Wireless Print Server.....	521
41X0568	MarkNet N8350 802.11 b/g/n Wireless Print Server with NFC.....	521
40X7592	Media present sensor.....	496
40X9100	Memory access door (MFP)	486
40X8777	MPF gearbox.....	499
40X8295	MPF pick roller and separator pad.....	499
40X8300	MPF solenoid.....	492
40X9131	MPF tray cover.....	486
41X0994	MPF tray links.....	486
40X9051	MPF USB cable	488
40X9050	MPF wireless cable.....	488
41X1946	N8230 Fiber ISP with Backpack	521
40X9101	Name plate cover.....	486
41X0259	Narrow media sensor.....	492
40X9102	Output expander.....	486
41X4453	Paper present sensor flag kit.....	496
40X8524	Parallel 1284-B interface card.....	521
40X8443	Pick roller assembly.....	502
41X0958	Pick tire.....	499
41X0363	Polygon laser scanning unit (LSU) frame*.....	492
41X0759	Polygon LSU cable*.....	492
41X0362	Polygon LSU*	492
40X0288	Power cord, 2.5 m (straight)—Argentina.....	519

P/N	Part name	Page
40X0301	Power cord, 2.5 m (straight)—Australia.....	519
40X4596	Power cord, 2.5 m (straight)—Brazil.....	519
40X0303	Power cord, 2.5 m (straight)—China.....	519
40X1774	Power cord, 2.5 m (straight)—Denmark.....	519
40X3141	Power cord, 2.5 m (straight)—Europe and others.....	519
40X0275	Power cord, 2.5 m (straight)—Israel.....	519
40X0270	Power cord, 2.5 m (straight)—Japan.....	519
40X1792	Power cord, 2.5 m (straight)—Korea.....	519
40X1773	Power cord, 2.5 m (straight)—South Africa.....	519
40X1772	Power cord, 2.5 m (straight)—Switzerland.....	519
40X1791	Power cord, 2.5 m (straight)—Taiwan.....	519
40X0273	Power cord, 2.5 m (straight)—Traditional Italy.....	519
40X0271	Power cord, 2.5 m (straight)—United Kingdom.....	519
40X0269	Power cord, 2.5 m (straight)—USA, Canada.....	519
40X7797	Power supply, 100 V/110 V.....	496
40X7798	Power supply, 220 V	496
41X0868	Prescribe card.....	521
40X9087	Rear cover.....	486
40X9082	Redrive assembly.....	499
40X8850	Redrive shaft.....	499
40X8700	Relocation kit.....	522
40X9110	Restraint pad.....	488
40X8301	Reverse solenoid.....	492
40X909	Right cover.....	486
0		
40X8523	RS-232C Serial Interface Card.....	521
40X9097	Scanner front cover.....	488
40X5315	Screw, shipped with ISP (2PER).....	521
40X7592	Sensor (stapler access door).....	506
40X8132	Sensor (stapler bin full receive).....	508
40X8131	Sensor (stapler bin full send).....	508
40X8754	Sensor (stapler left tamper HP).....	514
40X8754	Sensor (stapler paddle HP).....	514
40X8134	Sensor (stapler pass through).....	510

P/N	Part name	Page
40X7592	Sensor (stapler rear door).....	510
40X8754	Sensor (stapler right tamper HP).....	514
40X8444	Separator roll assembly.....	486, 502
40X9879	Smart card reader.....	522
40X9079	Speaker	488
40X9080	Speaker cable.....	488
40X5317	Standoff, tee with thumbscrew.....	521
40X8121	Staple finisher option.....	504
40X8149	Staple roll holder.....	506
40X8751	Stapler accumulator assembly.....	512
40X9116	Stapler cable.....	499
40X8142	Stapler carriage assembly.....	506
40X8129	Stapler cartridge access door.....	506
40X8137	Stapler controller card.....	508
40X8148	Stapler cooling fan.....	510
40X8752	Stapler diverter gearbox.....	516
40X9098	Stapler diverter spring.....	499
40X8139	Stapler door close limit switch with cable.....	506
40X8144	Stapler interface cable.....	506
40X8753	Stapler paddle motor.....	516
40X8135	Stapler power supply unit.....	510
40X8540	Stapler power supply unit—China.....	510
40X8128	Stapler rear door.....	510
40X8138	Stapler rear door close limit switch with cable.....	510
40X8130	Stapler right cover.....	506
40X8140	Stapler service cover.....	508
40X8750	Stapler tamper drive belt.....	514
40X8748	Stapler tamper main assembly.....	512
40X8125	Stapler tamper motor.....	508, 514
40X8141	Stapler top cover.....	508
40X8749	Tamper sub-assembly.....	514
41X4456	Toner density sensor kit.....	496
40X9099	Top cover.....	486
40X8045	Trailing edge sensor.....	496

P/N	Part name	Page
40X8393	Transfer roll.....	499
40X8458	Trapped staple access door.....	510
40X9523	Tray guide.....	499
40X7592	Tray present sensor.....	492
40X9052	UICC cable.....	490
40X9053	USB cable bracket.....	488
40X1368	USB cable, packaged (2 meters).....	521
41X0913	Video cable (galvo LSU).....	492

MX31x, MX41x

SCHEMATIC DIAGRAM



CAUTION—SHOCK HAZARD: This type of caution indicates a danger from hazardous voltage in the area of the product where you are working. Unplug the product before you start working, or use caution if the product must receive power to perform the task.



CAUTION—POTENTIAL INJURY: The lithium battery in this product is not intended to be replaced. There is a danger of explosion if a lithium battery is incorrectly replaced. Do not recharge, disassemble, or incinerate a lithium battery. Discard used lithium batteries according to the manufacturer's instructions and local regulations.

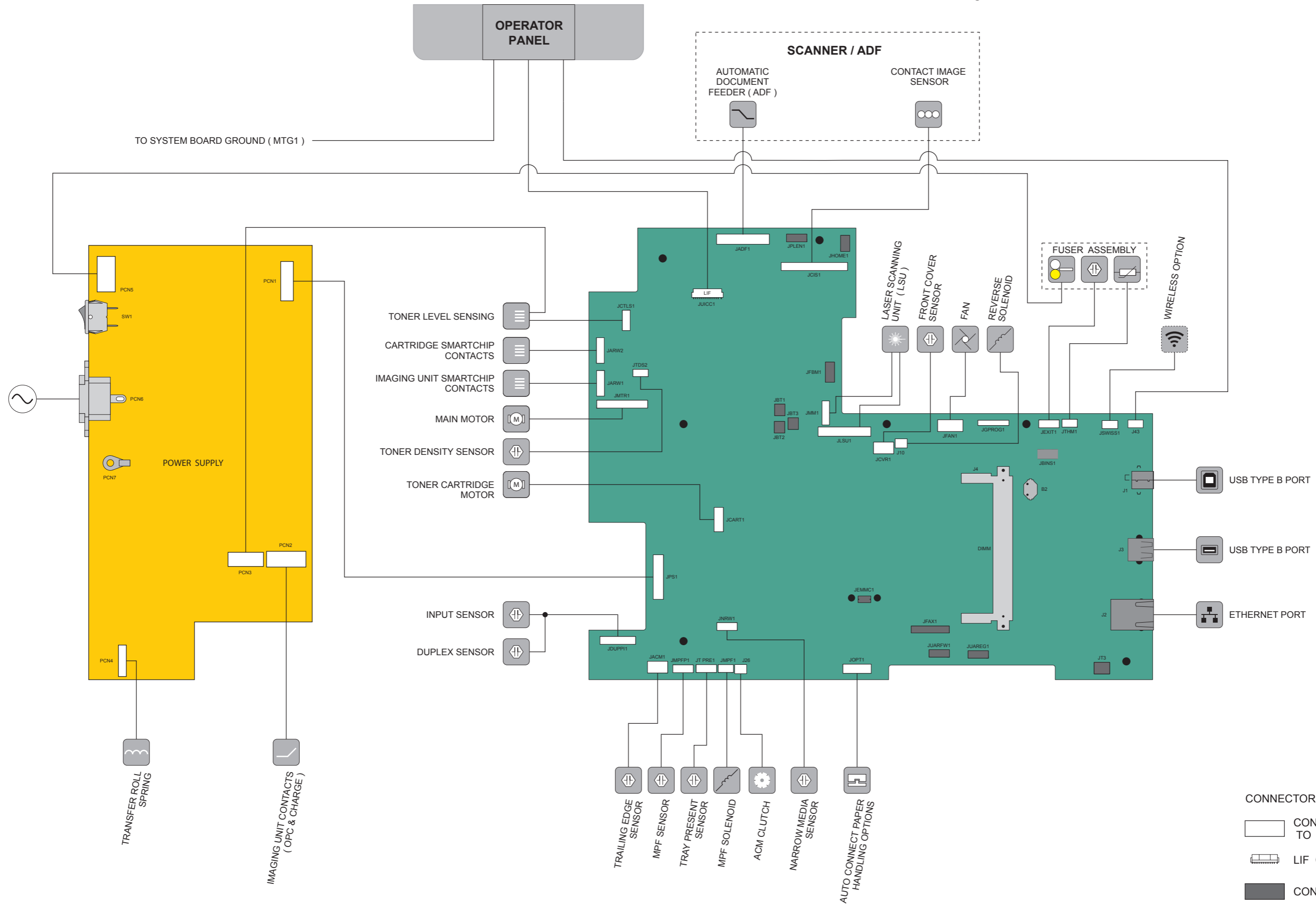

CONNECTOR LEGEND:

- CONNECTOR COMMON TO ALL
- LIF CONNECTOR
- CONNECTOR NOT IN USE

MX51x, MX61x

SCHEMATIC DIAGRAM



CAUTION—SHOCK HAZARD: This type of caution indicates a danger from hazardous voltage in the area of the product where you are working. Unplug the product before you start working, or use caution if the product must receive power to perform the task.



CAUTION—POTENTIAL INJURY: The lithium battery in this product is not intended to be replaced. There is a danger of explosion if a lithium battery is incorrectly replaced. Do not recharge, disassemble, or incinerate a lithium battery. Discard used lithium batteries according to the manufacturer's instructions and local regulations.

